

Norte del proyecto



Proyecto:



LE NID

Bayahibe, La Altagracia
Republica Dominicana

Propietario:

Leyenda

	101		105
	102		106
	103		107
	104		

Equipo de trabajo

Diseño Arquitectonico:

Arq. Frederich Cedano

Codia:

Arq. Colaboradores:

Arq. Gabriela Moreno

Plano

BLOQUE A-NIVEL 1

A101

Escala

As indicated

Fecha:
AGOSTO
2024

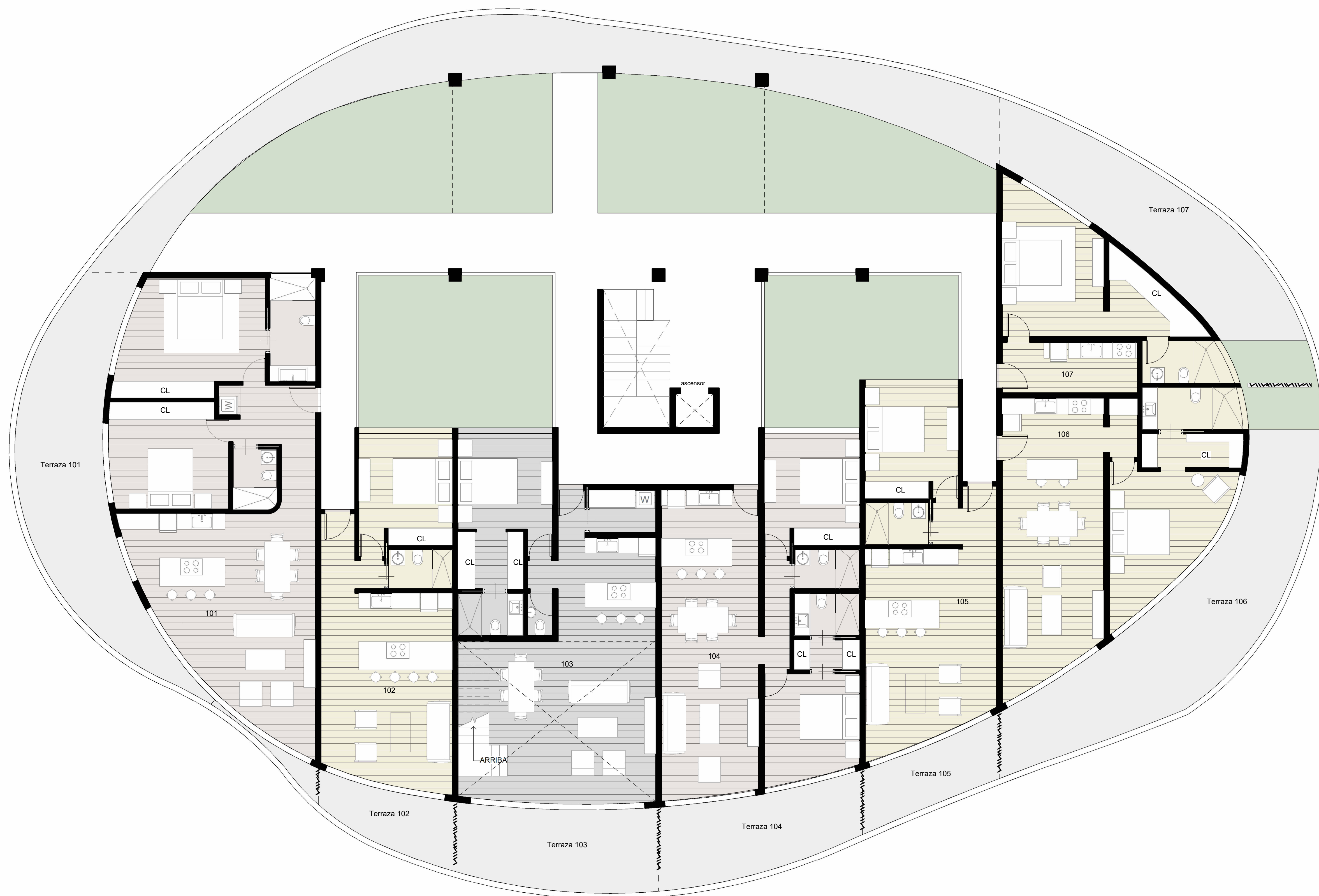

**BLOQUE A
NIVEL 1**

Apt.	No. habitaciones	Area	Area 2do nivel	Area terraza	Area total
101	2	99 m ²		39 m ²	138 m ²
102	1	54 m ²		10 m ²	64 m ²
103	2	84 m ²	43 m ²	22 m ²	149 m ²
104	2	80 m ²		21 m ²	101 m ²
105	1	53 m ²		11 m ²	64 m ²
106	1	67 m ²		51 m ²	118m ²
107	1	39 m ²		38 m ²	77m ²

SITEPLAN

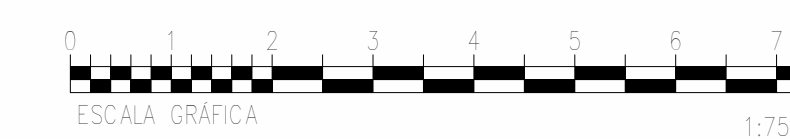
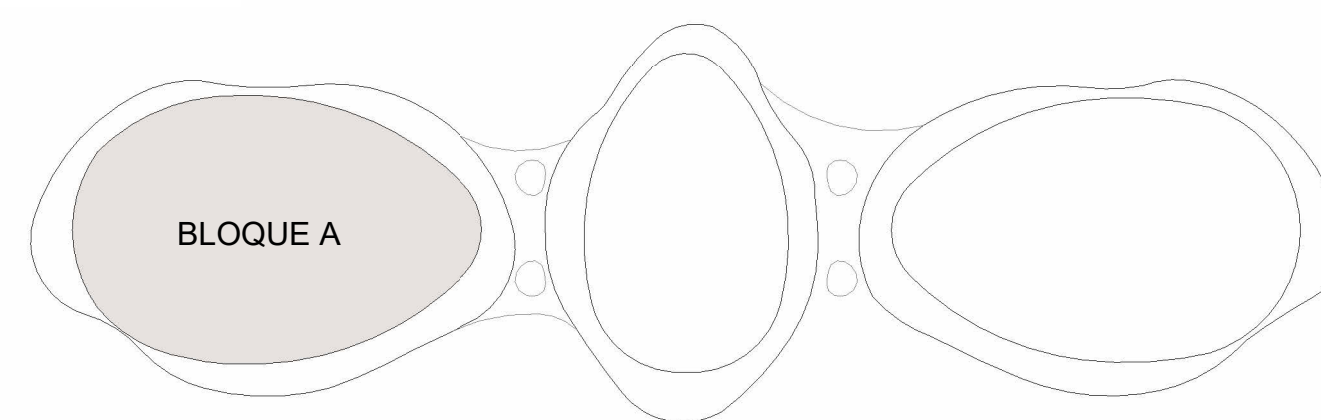

1 BLOQUE A- NIVEL 1
1:75

Norte del proyecto



Proyecto:



LE NID

Bayahibe, La Altagracia
Republica Dominicana

Propietario:

Leyenda

103	205
201	206
202	207
204	208

Equipo de trabajo

Diseño Arquitectónico:

Arq. Frederich Cedano

Codia:

Arq. Colaboradores:

Arq. Gabriela Moreno

Plano

BLOQUE A - NIVEL 2

A102

Escala

As indicated

Fecha:

AGOSTO
2024

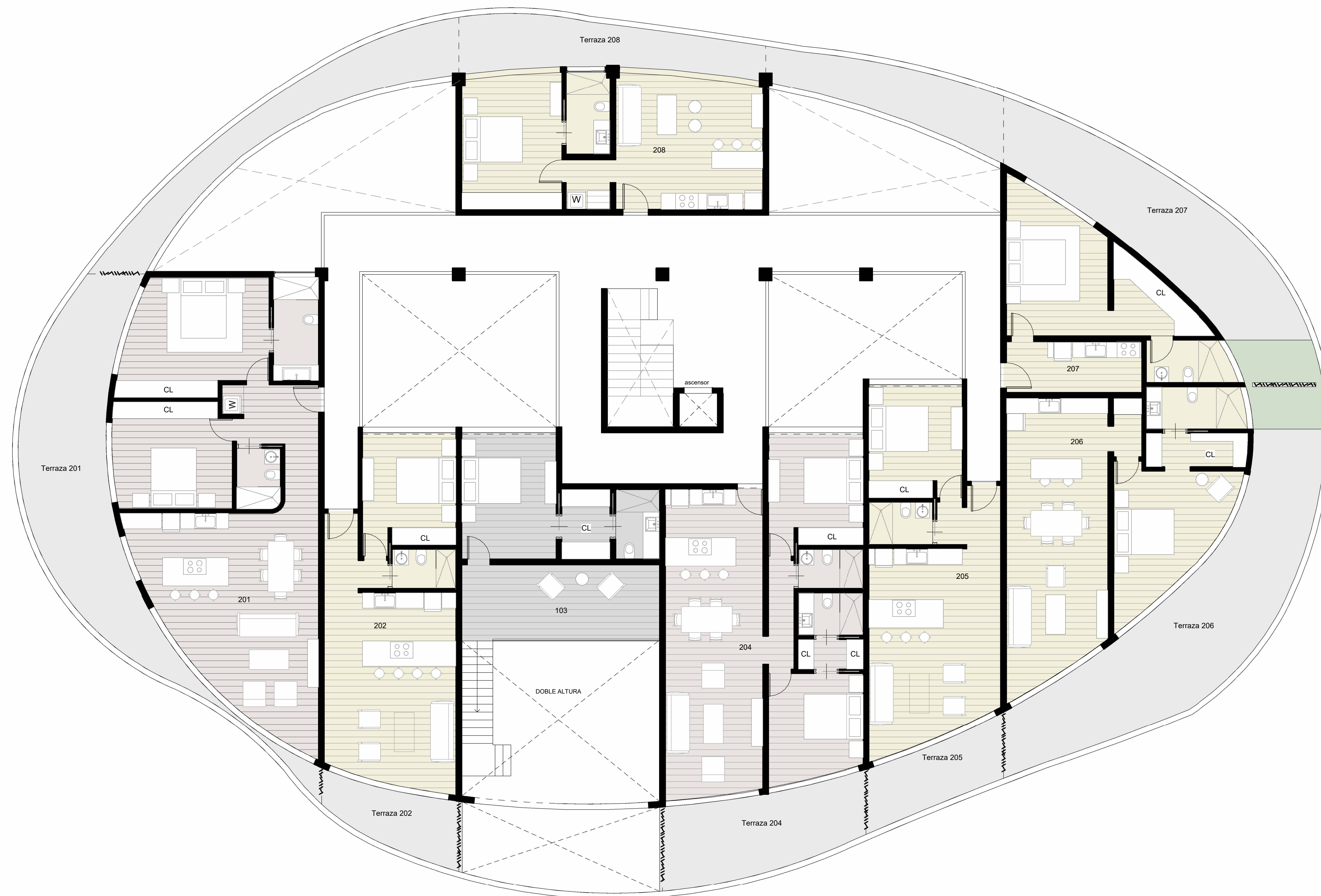

**BLOQUE A
NIVEL 2**

APT.	No. habitaciones	AREA	Area 1er nivel	Area terraza	Area total
201	2	99 m ²	39 m ²	10 m ²	138 m ²
202	1	53 m ²	21 m ²	12 m ²	101 m ²
204	2	80 m ²	51 m ²	12 m ²	117 m ²
205	1	53 m ²	39 m ²	17 m ²	101 m ²
206	1	66 m ²	38 m ²	10 m ²	117 m ²
207	1	39 m ²	21 m ²	12 m ²	65 m ²
208	1	51 m ²	10 m ²	17 m ²	68 m ²

SITEPLAN

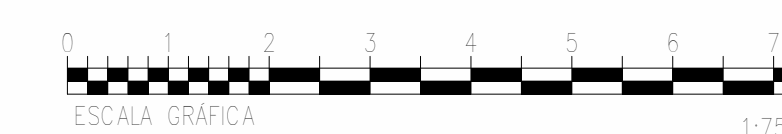
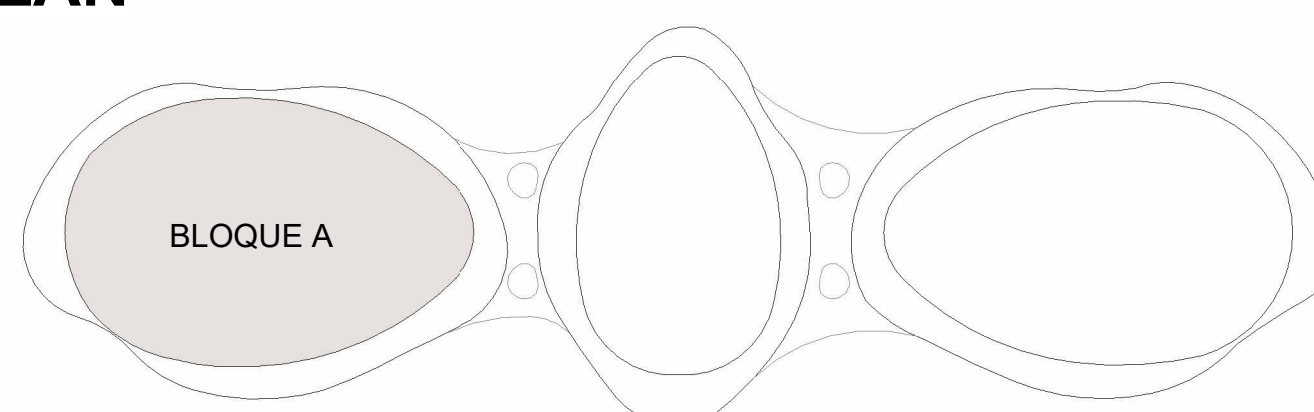

① BLOQUE A-NIVEL 2
1:75

Norte del proyecto



Proyecto:



LE NID

Bayahibe, La Altagracia
Republica Dominicana

Propietario:

Leyenda

301	305
302	306
303	307
304	308

Equipo de trabajo

Diseño Arquitectonico:

Arq. Frederich Cedano

Codia:

Arq. Colaboradores:

Arq. Gabriela Moreno

Plano

BLOQUE A - NIVEL 3

A103

Escala

As indicated

Fecha:

AGOSTO
2024

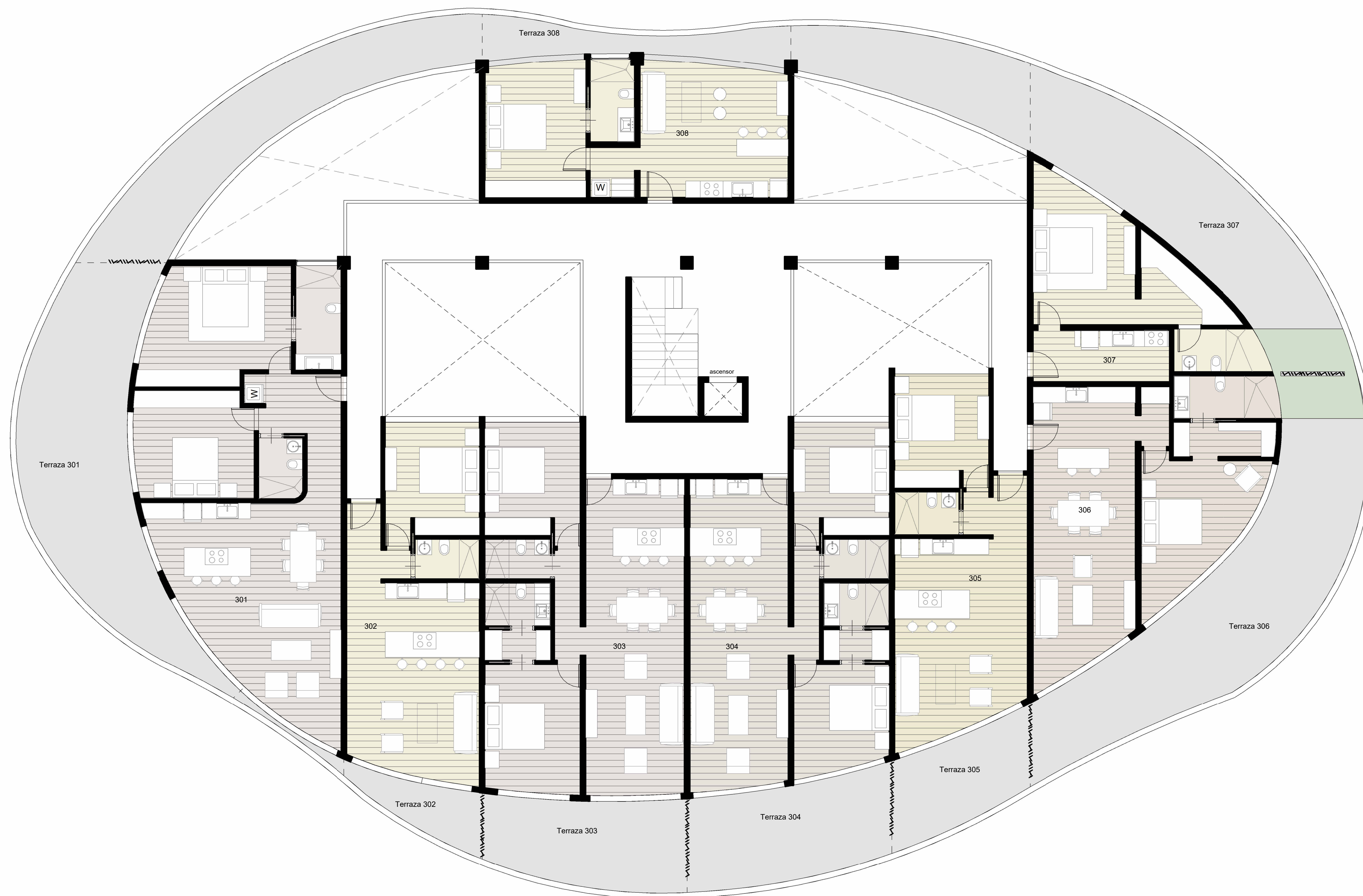

**BLOQUE A
NIVEL 3**

Apt.	No. habitaciones	Area	Area terraza	Area total
301	2	99 m ²	52 m ²	151 m ²
302	1	54 m ²	8 m ²	62 m ²
303	2	84 m ²	22 m ²	106 m ²
304	2	81 m ²	25 m ²	106 m ²
305	1	53 m ²	16 m ²	69 m ²
306	1	67 m ²	60 m ²	127 m ²
307	1	39 m ²	44 m ²	83 m ²
308	1	50 m ²	13 m ²	63 m ²

SITEPLAN

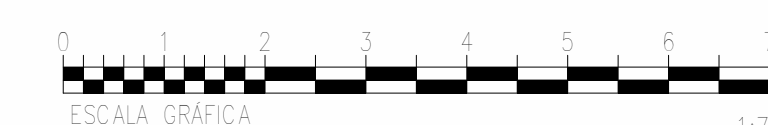
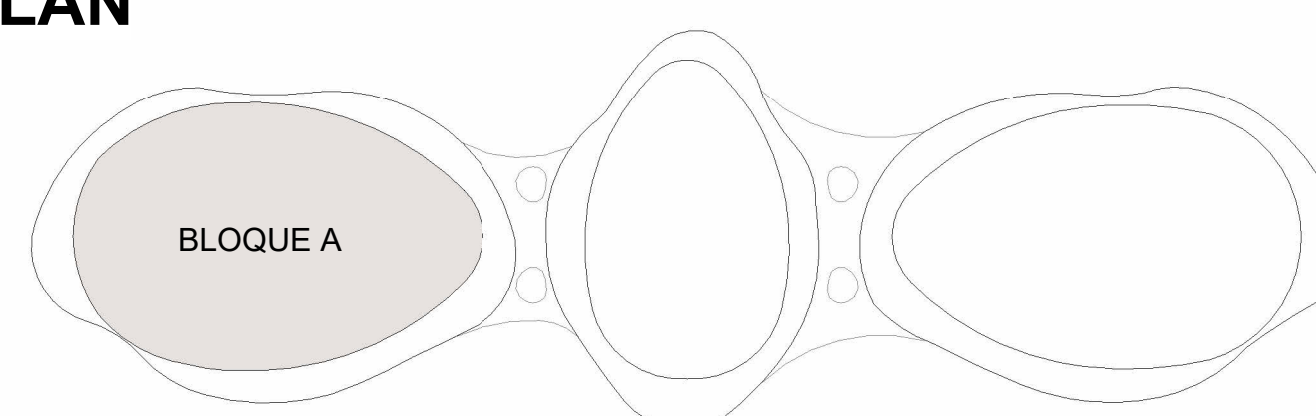

② BLOQUE A - NIVEL 3
1 : 75

Norte del proyecto



Proyecto:



LE NID

Bayahibe, La Altagracia
Republica Dominicana

Propietario:

Leyenda

	401		405
	402		406
	403		407
	404		

Equipo de trabajo

Diseño Arquitectonico:

Arq. Frederich Cedano

Codia:

Arq. Colaboradores:

Arq. Gabriela Moreno

Plano

BLOQUE A - NIVEL 4

A104

Escala

As indicated

Fecha:
AGOSTO
2024

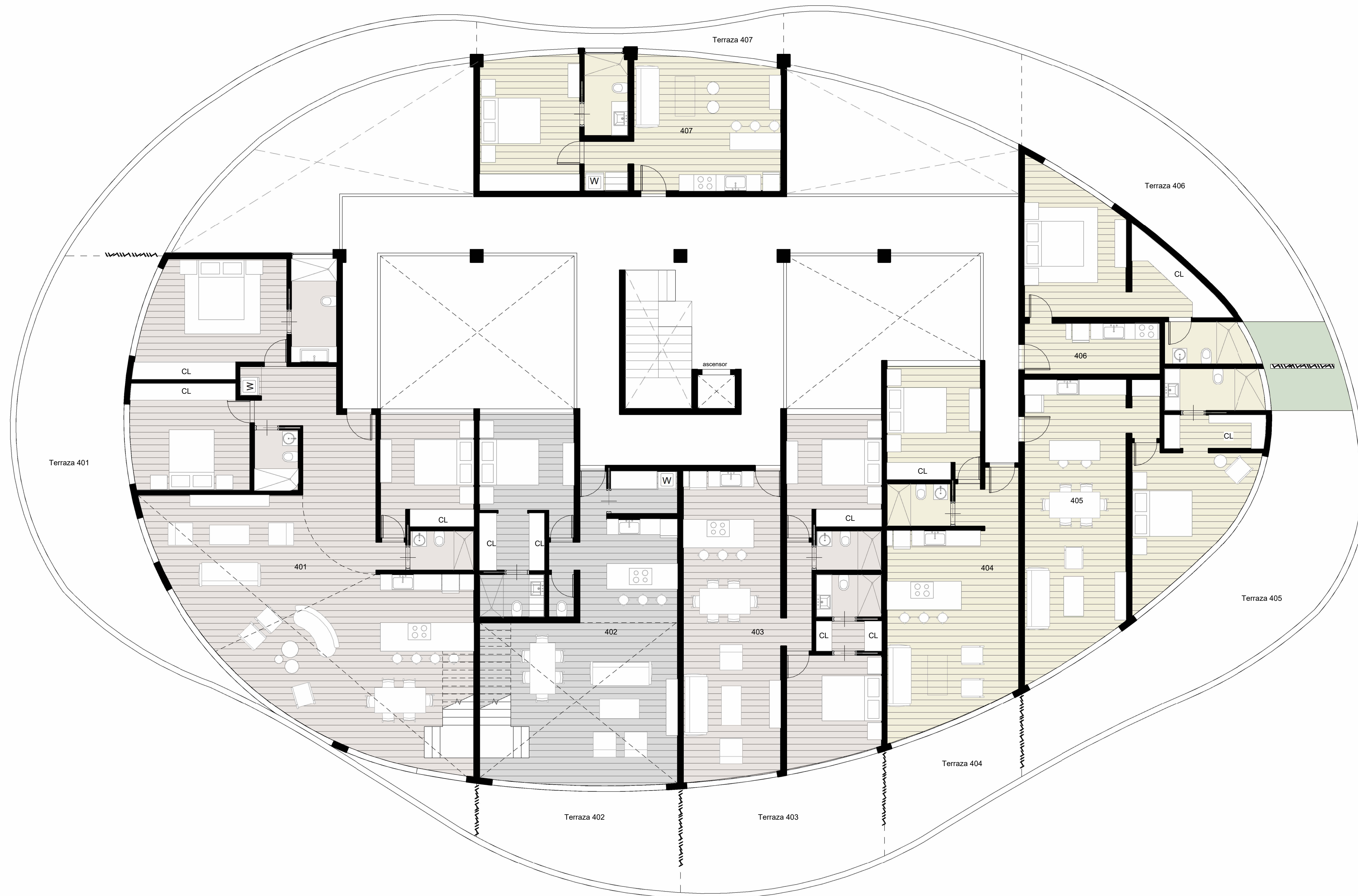

**BLOQUE A
NIVEL 4**

Apt.	No. habitaciones	Area	Area 2do nivel	Area terraza	Area terraza techo	Area total
401	3	158 m ²	86 m ²	103 m ²	199 m ²	546 m ²
402	2	83 m ²	38 m ²	23 m ²	98 m ²	242 m ²
403	2	81 m ²		29 m ²		110 m ²
404	2	53 m ²		17 m ²		70 m ²
405	1	66 m ²		61 m ²		127 m ²
406	1	39 m ²		43 m ²		82 m ²
407	1	50 m ²		11 m ²		61 m ²

SITEPLAN

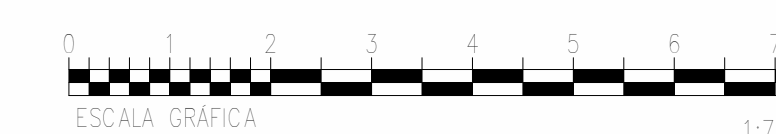
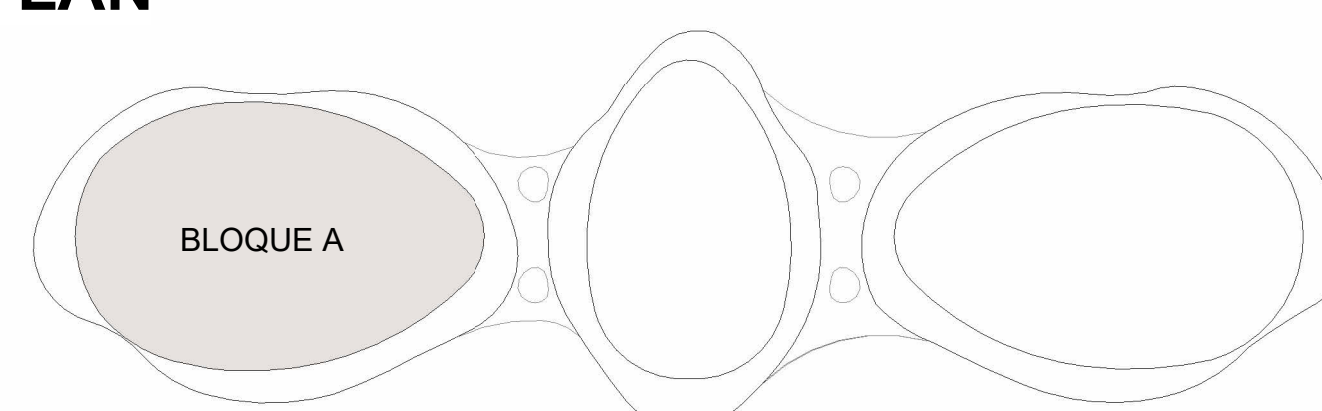

2 BLOQUE A - NIVEL 4
1:75

Norte del proyecto



Proyecto:



LE NID

Bayahibe, La Altagracia
Republica Dominicana

Propietario:

Leyenda

- 401
- 402
- 503
- 504
- 505
- 506

Equipo de trabajo

Diseño Arquitectonico:

Arq. Frederich Cedano

Codia:

Arq. Colaboradores:

Arq. Gabriela Moreno

Plano

BLOQUE A - NIVEL 5

A105

Escala

As indicated

Fecha:
AGOSTO
2024

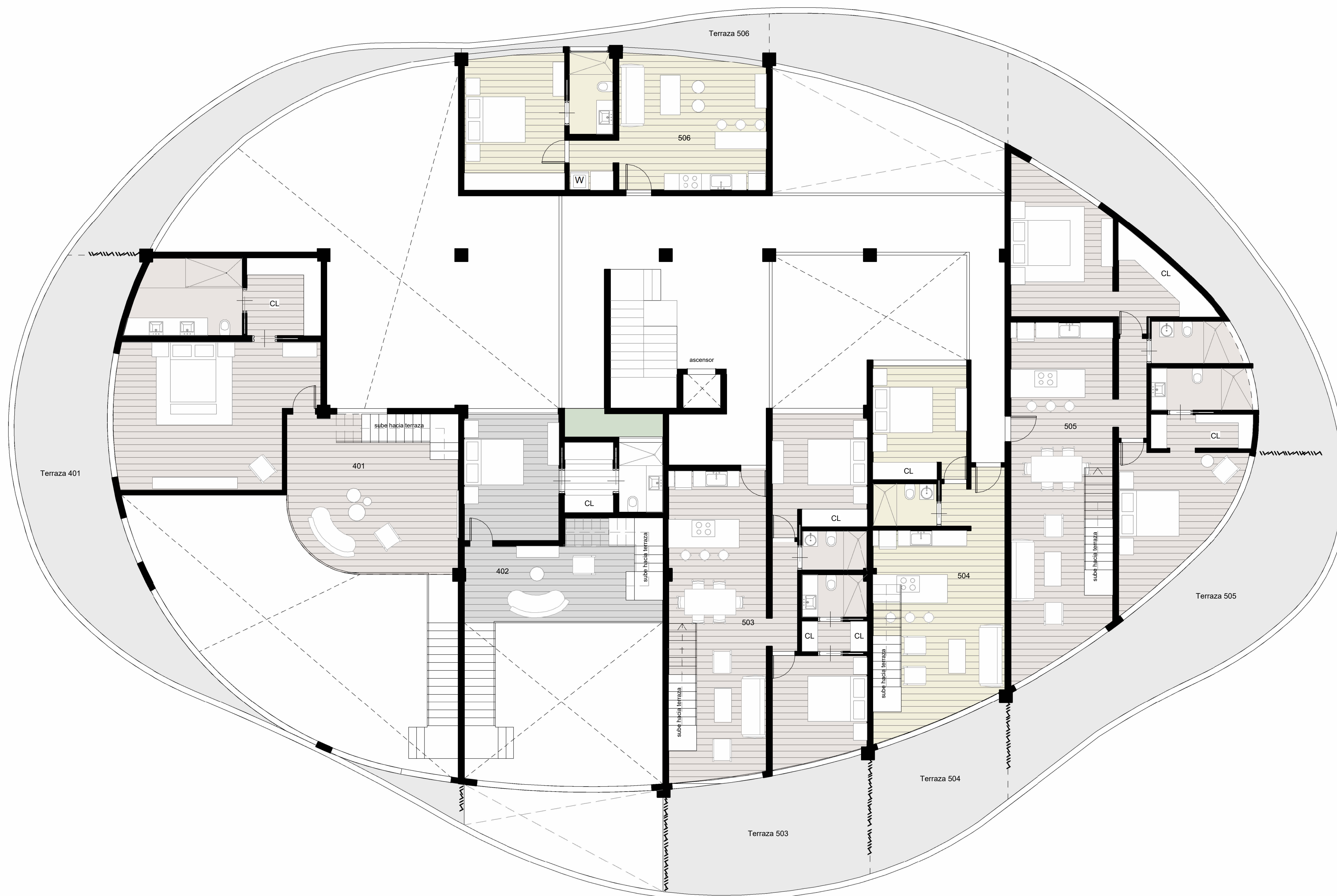

**BLOQUE A
NIVEL 5**

APT.	No. habitaciones	AREA	Area 1er nivel	Area terraza	Area terraza techo	Area total
401	3	86 m ²	158 m ²	103 m ²	199 m ²	546 m ²
402	2	38 m ²	83 m ²	23 m ²	98 m ²	242 m ²
503	2	80 m ²	30 m ²	106 m ²	217 m ²	217 m ²
504	1	53 m ²	21 m ²	73 m ²	147 m ²	147 m ²
505	2	107 m ²	95 m ²	155 m ²	357 m ²	357 m ²
506	1	50 m ²	9 m ²	59 m ²	59 m ²	59 m ²

SITEPLAN

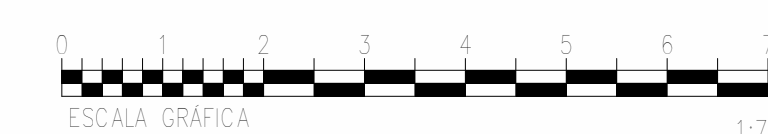
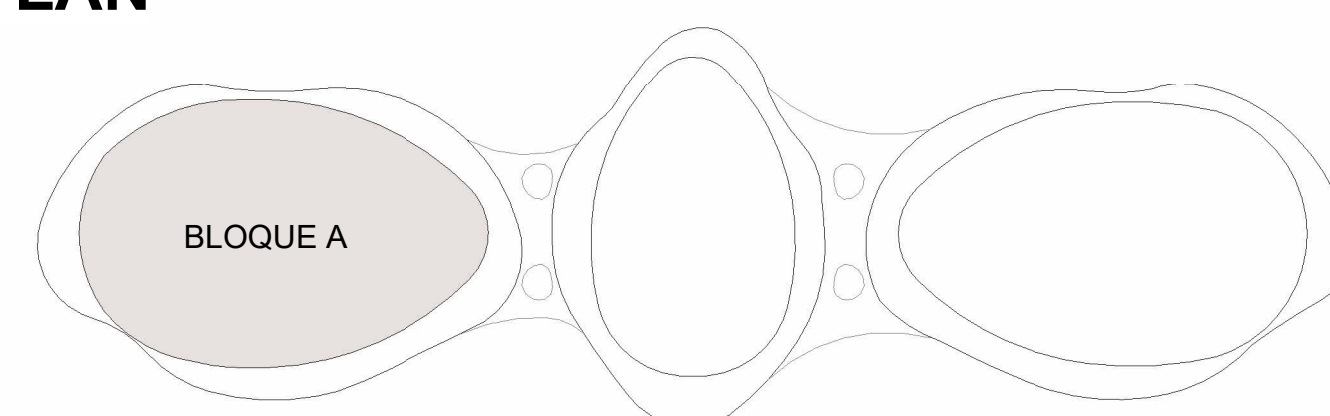

1 BLOQUE A - NIVEL 5
1 : 75

Norte del proyecto



Proyecto:



LE NID

Bayahibe, La Altagracia
Republica Dominicana

Propietario:

Leyenda

- 401
- 402
- 503
- 504
- 505

Equipo de trabajo

Diseño Arquitectonico:

Arq. Frederich Cedano

Codia:

Arq. Colaboradores:

Arq. Gabriela Moreno

Plano

BLOQUE A - NIVEL 6

A106

Escala

As indicated

Fecha:
AGOSTO
2024

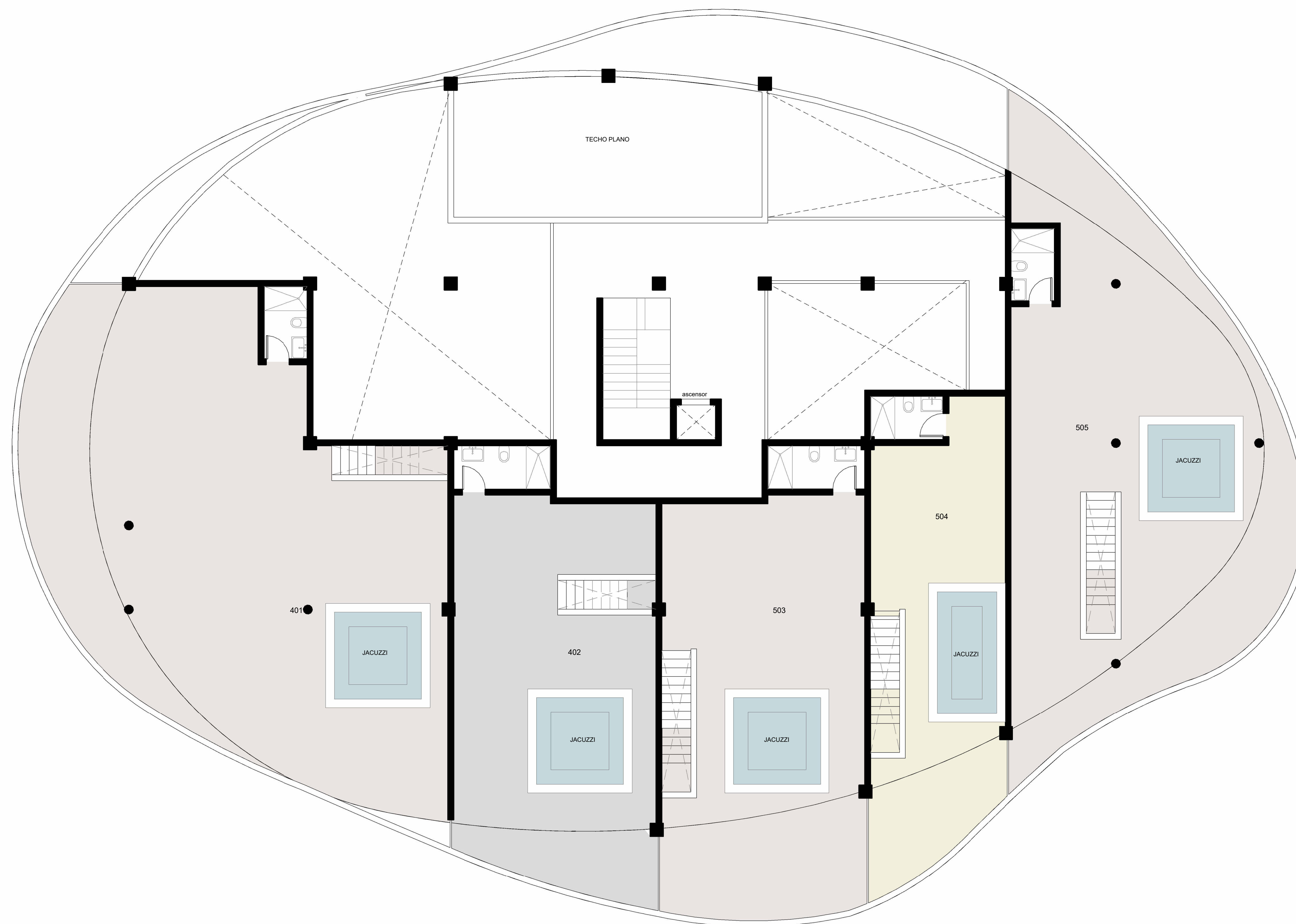

**BLOQUE A
NIVEL 6**

APT.	No. habitaciones	AREA	Area 1er nivel	Area terraza	Area terraza techo	Area total
401	3	86 m ²	158 m ²	103 m ²	199 m ²	546 m ²
402	2	38 m ²	83 m ²	23 m ²	98 m ²	242 m ²
503	2	80 m ²	30 m ²	106 m ²	217 m ²	217 m ²
504	1	53 m ²	21 m ²	73 m ²	147 m ²	147 m ²
505	2	107 m ²	95 m ²	155 m ²	357 m ²	357 m ²
506	1	50 m ²	9 m ²		59 m ²	59 m ²

SITEPLAN

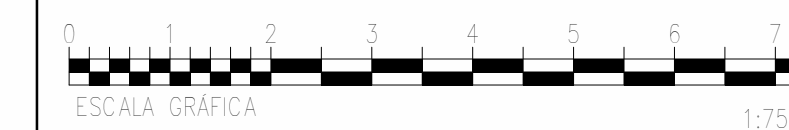
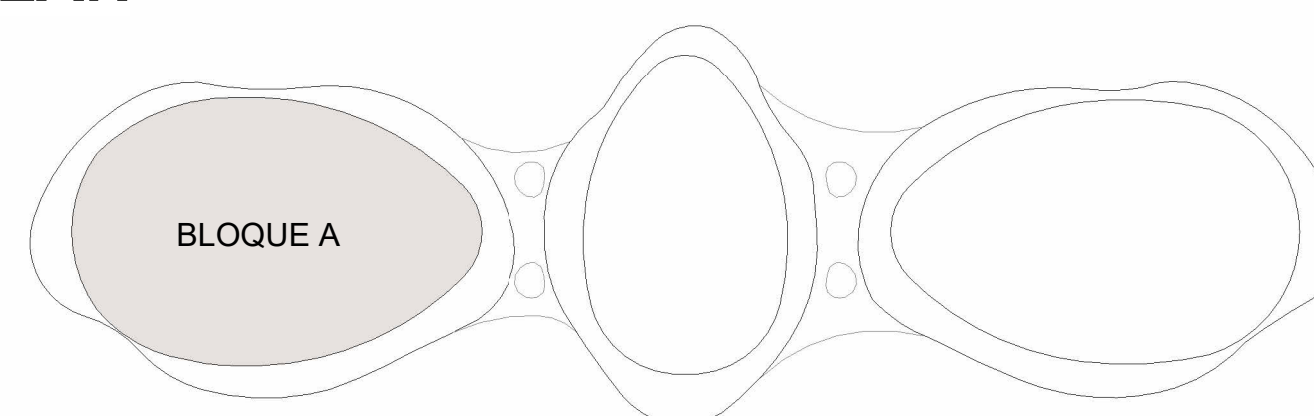

1 BLOQUE A - NIVEL 6
1 : 75

Norte del proyecto



Proyecto:



LE NID

Bayahibe, La Altagracia
Republica Dominicana

Propietario:

Leyenda

- 01 SALA
- 02 COCINA
- 03 COMEDOR
- 04 HABITACION SECUNDARIA
- 05 BAÑO 1
- 06 HABITACION PRINCIPAL
- 07 LAVADORA-SECADORA
- 08 BAÑO 2
- 09 TERRAZA

Equipo de trabajo

Diseño Arquitectonico:

Arq. Frederich Cedano

Codia:

Arq. Colaboradores:

Arq. Gabriela Moreno

Plano

Apartamento 101- BLOQUE A

A201

Escala

As indicated

Fecha:

AGOSTO
2024

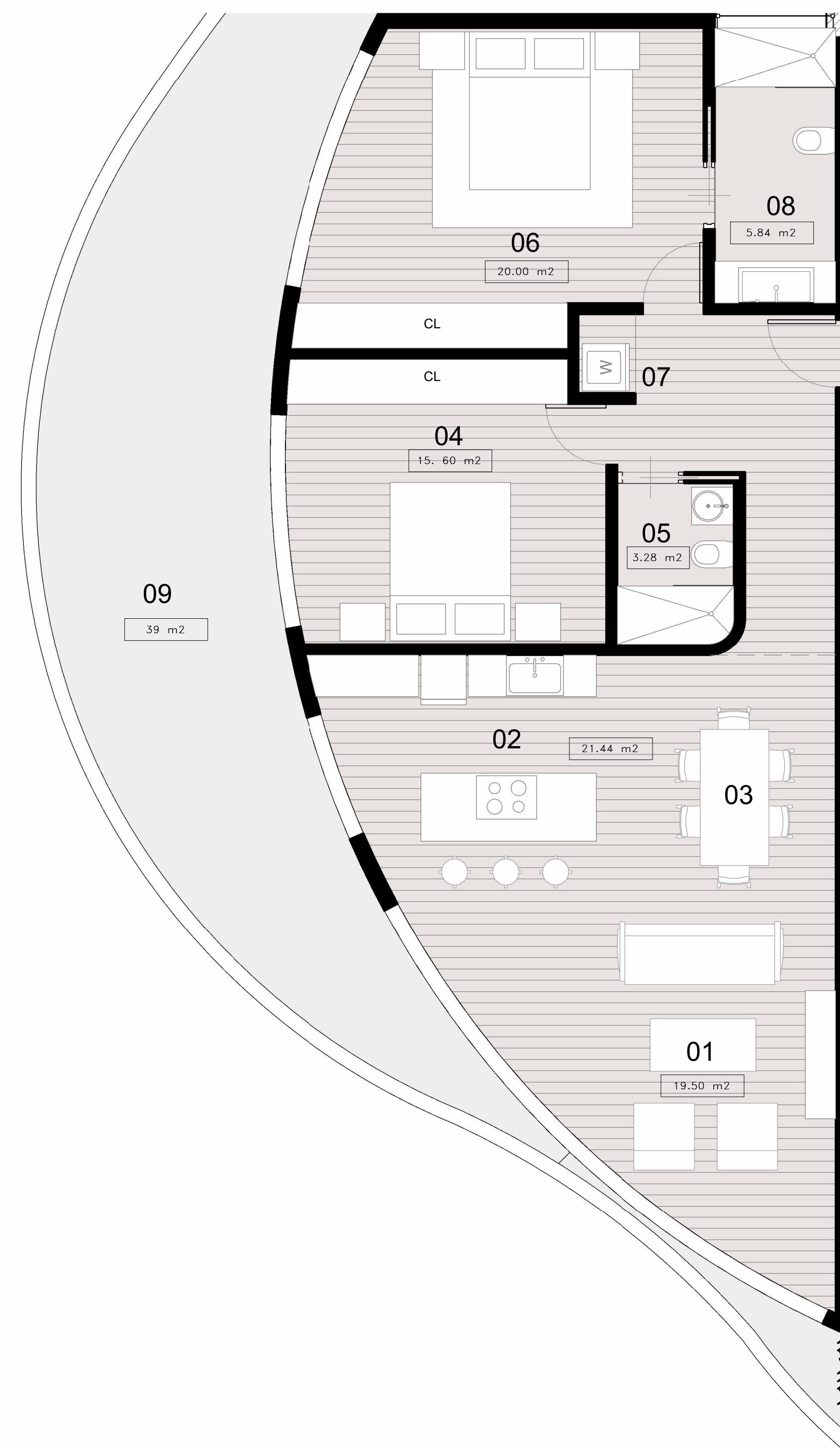

BLOQUE A
APARTAMENTO 101
DOS HABITACIONES

AREA INTERIOR TOTAL 99 m2
AREA TERRAZA 39 m2
AREA TOTAL 138 m2

SITEPLAN

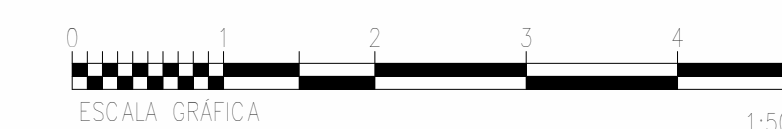
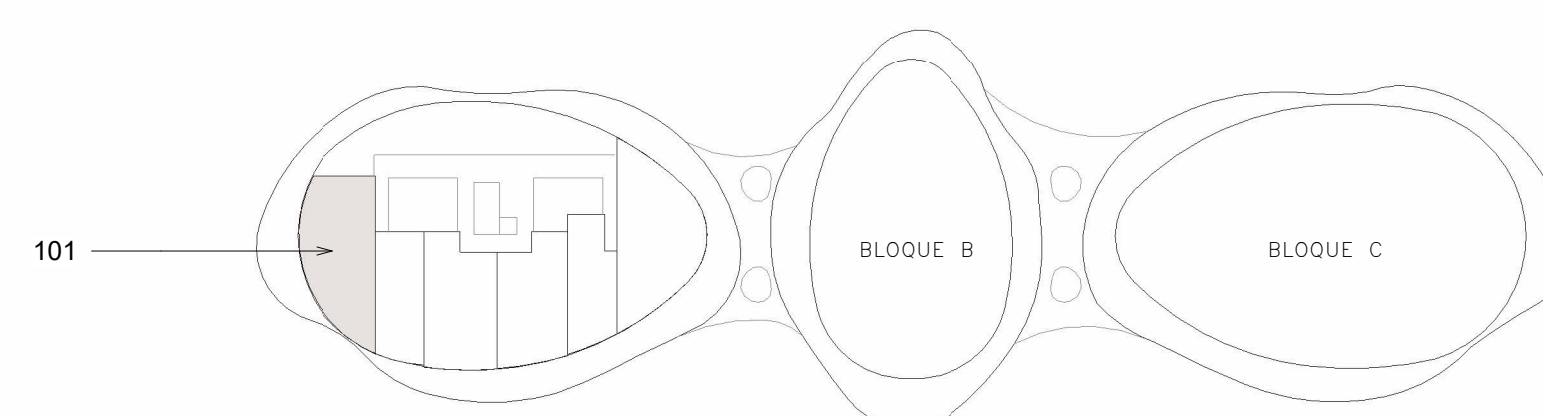

1 Bloque A - apt 101
1 : 50

Norte del proyecto



Proyecto:



LE NID

Bayahibe, La Altagracia
Republica Dominicana

Propietario:

Leyenda

- 01 SALA
- 02 COCINA
- 03 COMEDOR
- 04 HABITACION SECUNDARIA
- 05 BAÑO 1
- 06 HABITACION PRINCIPAL
- 07 LAVADORA-SECADORA
- 08 BAÑO 2
- 09 TERRAZA

Equipo de trabajo

Diseño Arquitectonico:

Arq. Frederich Cedano

Codia:

Arq. Colaboradores:

Arq. Gabriela Moreno

Plano

Apartamento 102 -BLOQUE A

A202

Escala

As indicated

Fecha:

AGOSTO
2024

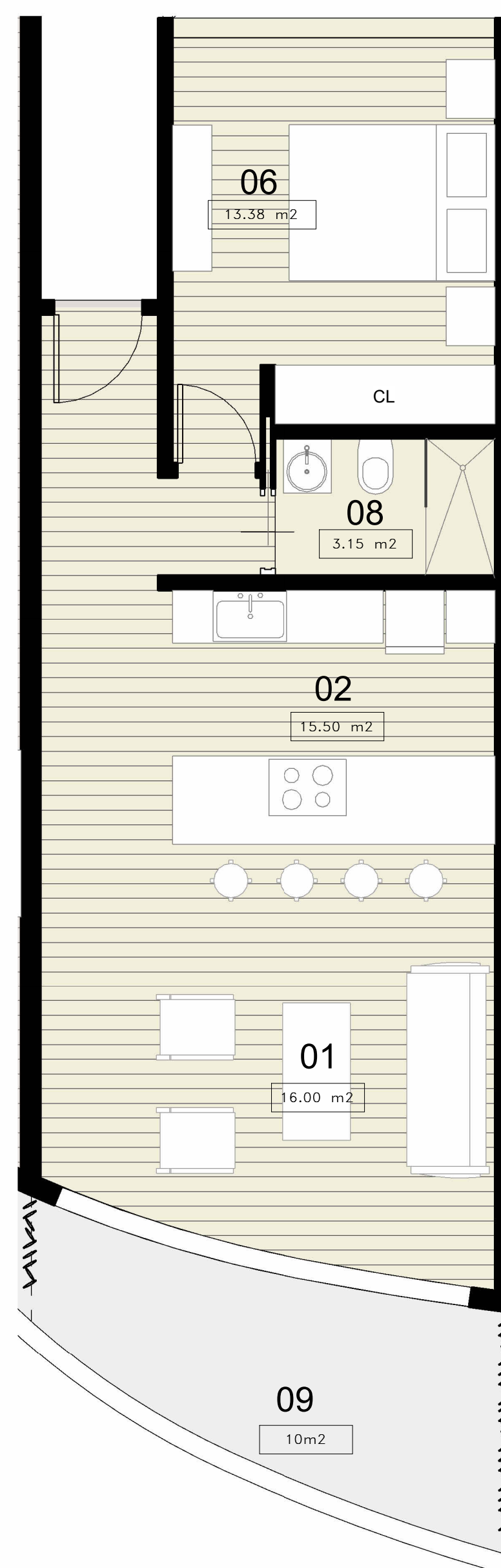

BLOQUE A
APARTAMENTO 102

UNA HABITACION

AREA INTERIOR TOTAL 54 m2

AREA TERRAZA 10 m2

AREA TOTAL 64 m2

SITEPLAN

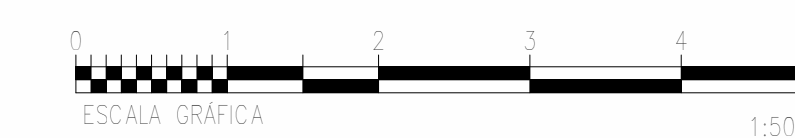
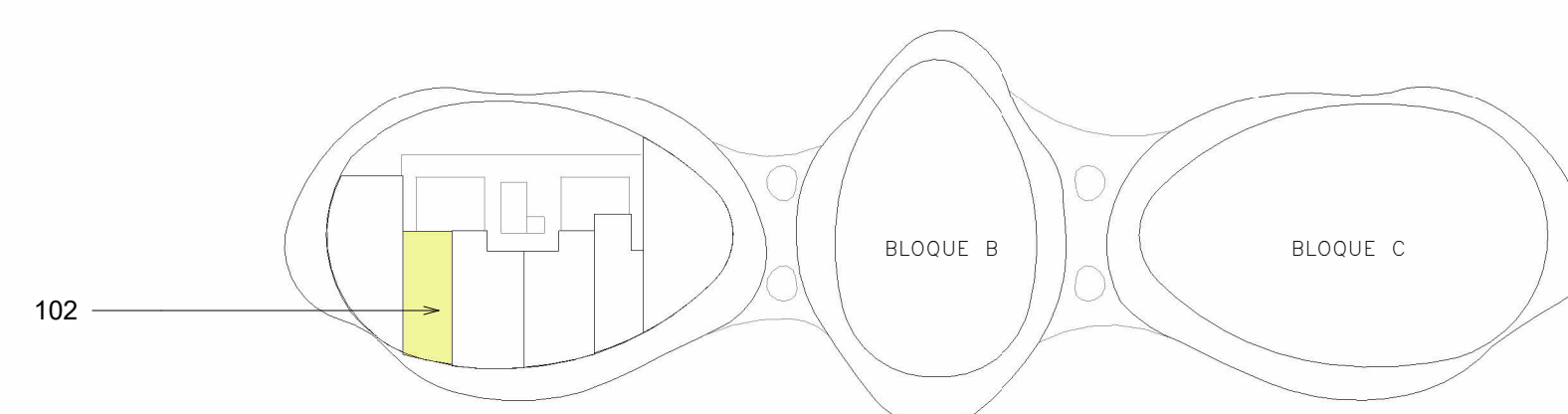

① Bloque A-apt 102
1 : 50

Norte del proyecto



Proyecto:



LE NID

Bayahibe, La Altagracia
Republica Dominicana

Propietario:

Leyenda

- 01 SALA
- 02 COCINA
- 03 COMEDOR
- 04 HABITACION SECUNDARIA
- 05 BAÑO 1
- 06 HABITACION PRINCIPAL
- 07 LAVADORA-SECADORA
- 08 BAÑO 2
- 09 TERRAZA
- 10 BAÑO 3

Equipo de trabajo

Diseño Arquitectonico:

Arq. Frederich Cedano

Codia:

Arq. Colaboradores:

Arq. Gabriela Moreno

Plano

Apartamento 103 -BLOQUE A

A203

Escala

As indicated

Fecha:

AGOSTO
2024

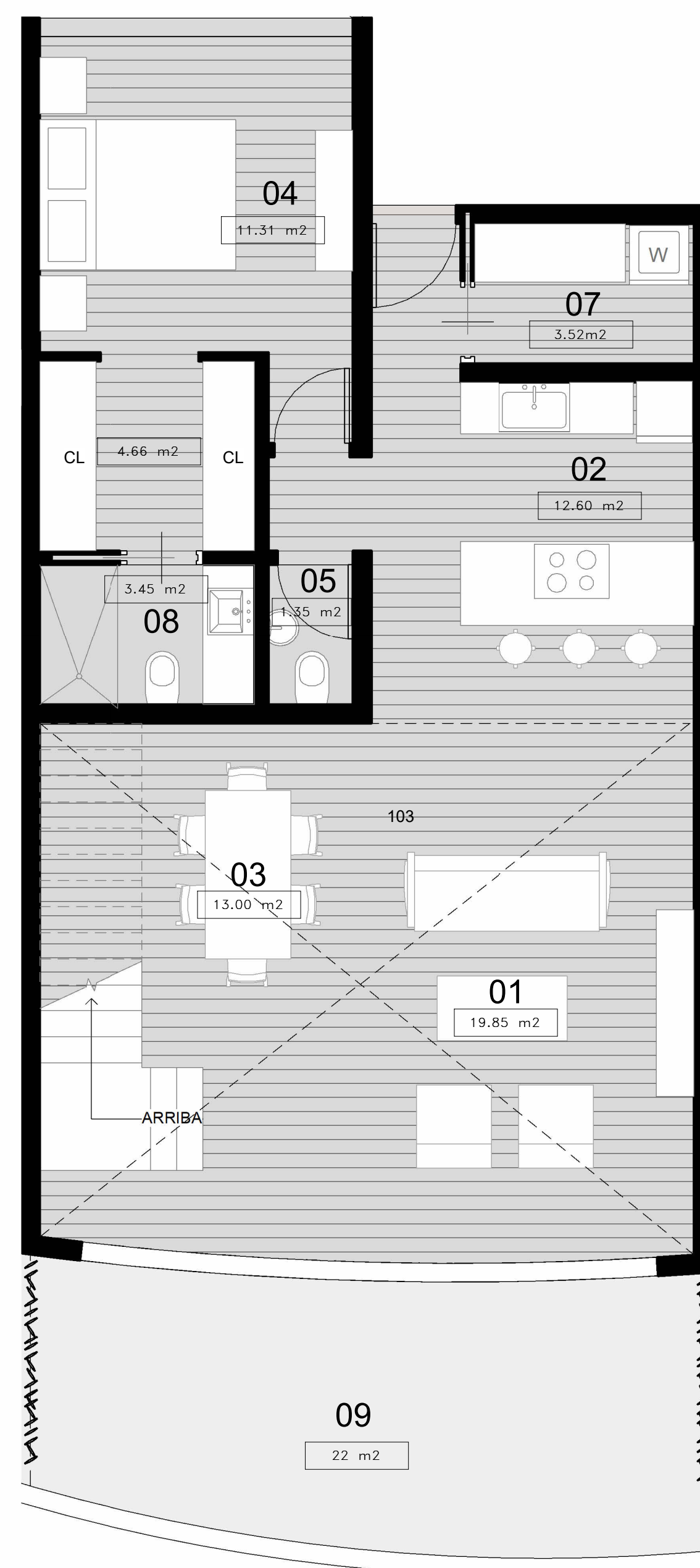

1 Bloque A- apt 103 1er nivel
1 : 50

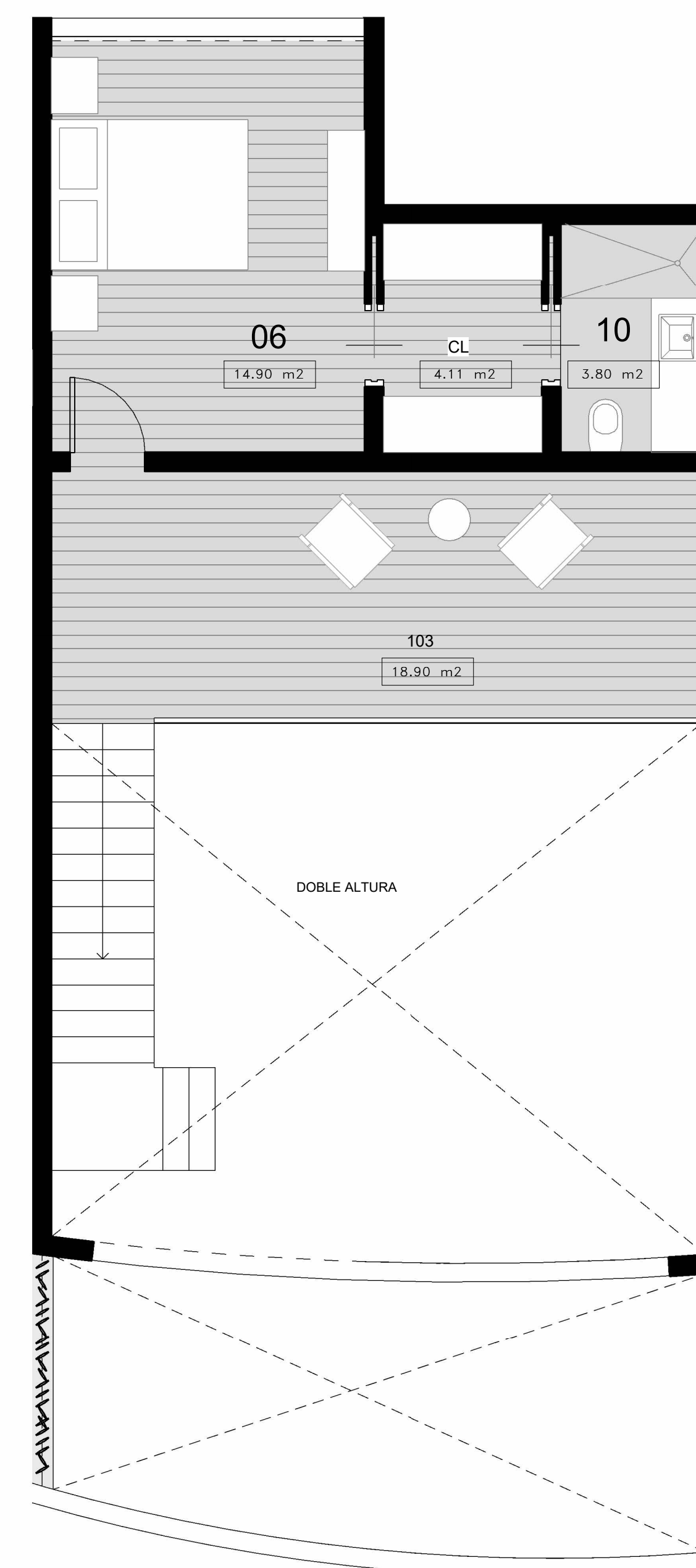

3 Bloque A- apt 103 2do nivel
1 : 50

BLOQUE A
APARTAMENTO 103

LOFT
DOS HABITACIONES

AREA INTERIOR TOTAL 127 m2

AREA TERRAZA 22 m2

AREA TOTAL 149 m2

SITEPLAN

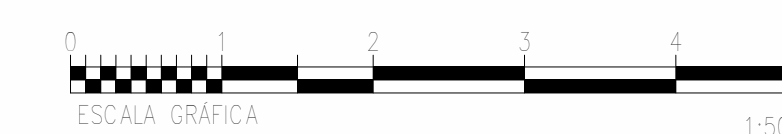
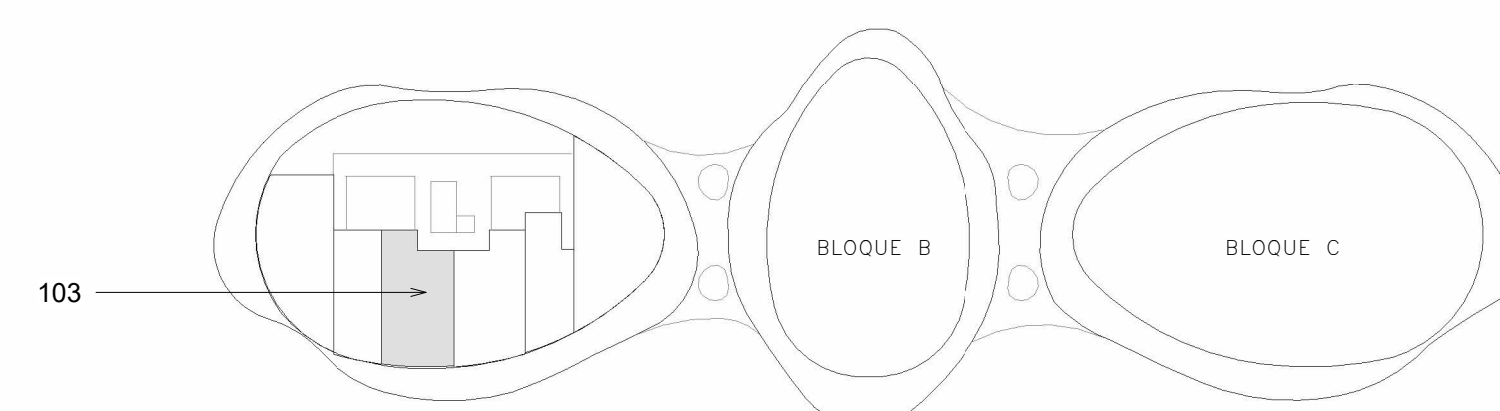

Norte del proyecto



Proyecto:



LE NID

Bayahibe, La Altagracia
Republica Dominicana

Propietario:

Leyenda

- 01 SALA
- 02 COCINA
- 03 COMEDOR
- 04 HABITACION SECUNDARIA
- 05 BAÑO 1
- 06 HABITACION PRINCIPAL
- 07 LAVADORA-SECADORA
- 08 BAÑO 2
- 09 TERRAZA

Equipo de trabajo

Diseño Arquitectonico:

Arq. Frederich Cedano

Codia:

Arq. Colaboradores:

Arq. Gabriela Moreno

Plano

Apartamento 104- BLOQUE A

A204

Escala

As indicated

Fecha:

AGOSTO
2024

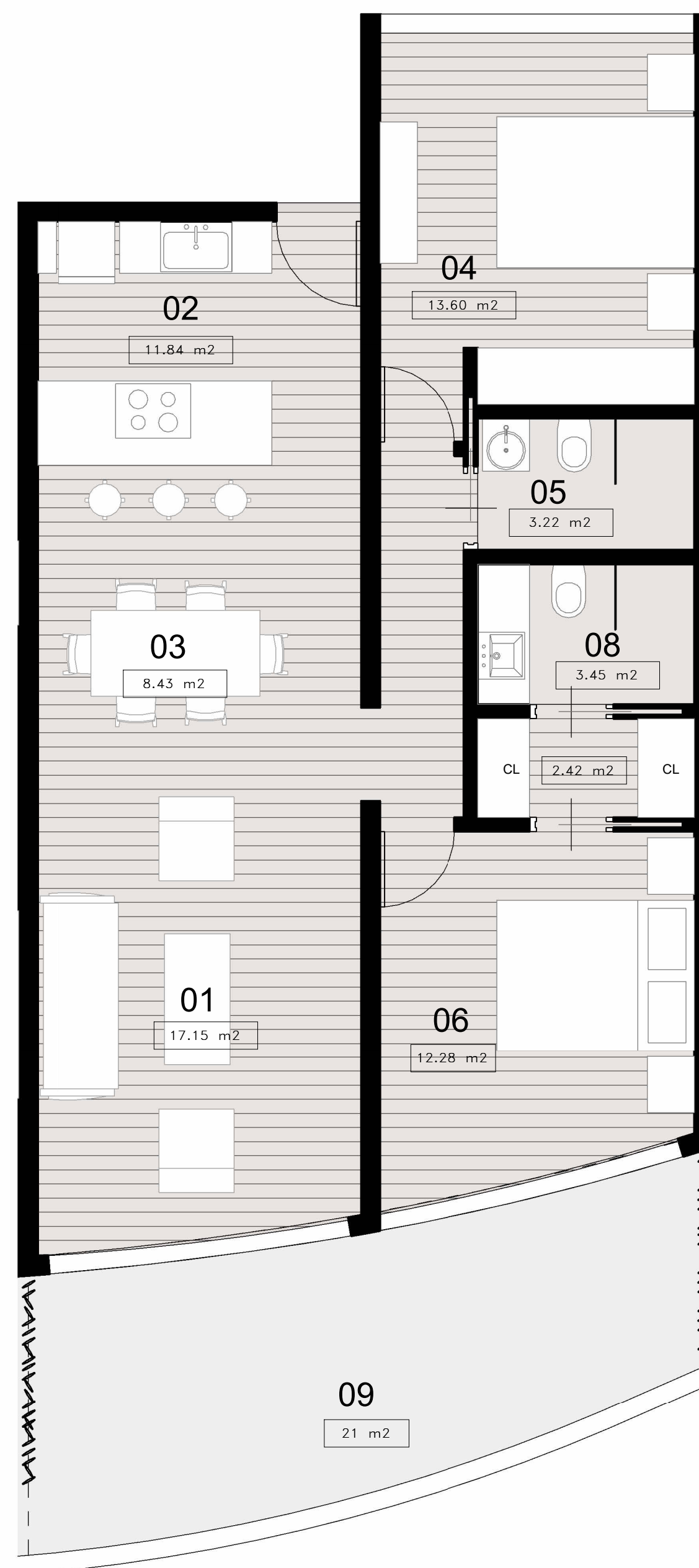

BLOQUE A
APARTAMENTO 104

DOS HABITACIONES

AREA INTERIOR TOTAL 80 m2

AREA TERRAZA 21 m2

AREA TOTAL 101 m2

SITEPLAN

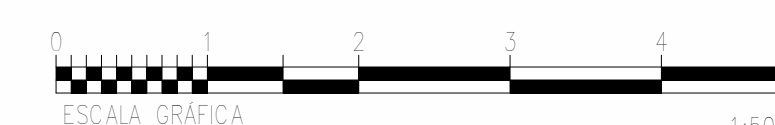
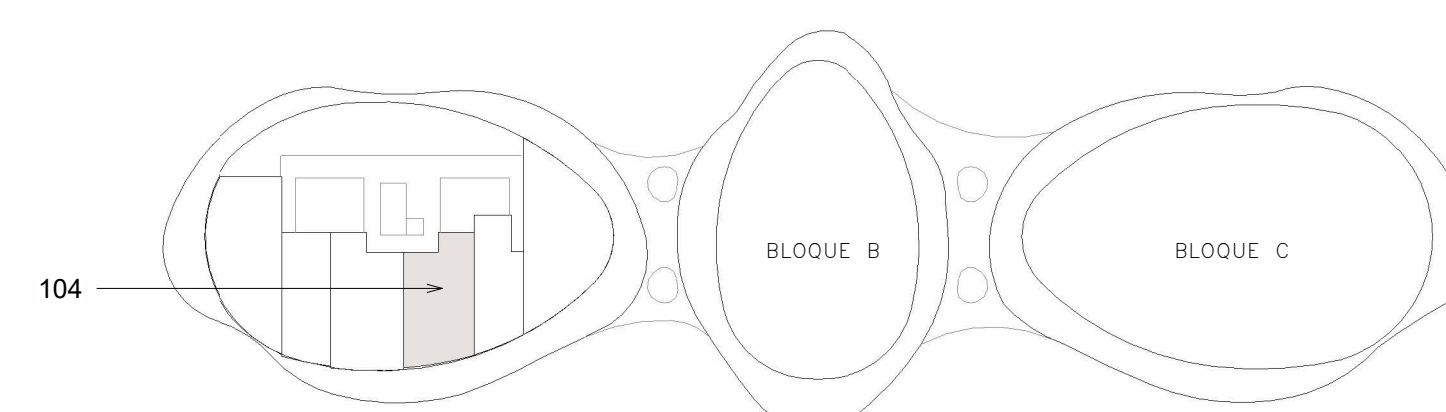

1 Bloque A- apt 104
1 : 50

Norte del proyecto



Proyecto:



LE NID

Bayahibe, La Altagracia
Republica Dominicana

Propietario:

Leyenda

- 01 SALA
- 02 COCINA
- 03 COMEDOR
- 04 HABITACION SECUNDARIA
- 05 BAÑO 1
- 06 HABITACION PRINCIPAL
- 07 LAVADORA-SECADORA
- 08 BAÑO 2
- 09 TERRAZA

Equipo de trabajo

Diseño Arquitectonico:

Arq. Frederich Cedano

Codia:

Arq. Colaboradores:

Arq. Gabriela Moreno

Plano

Apartamento 105 -BLOQUE A

A205

Escala

As indicated

Fecha:

AGOSTO
2024

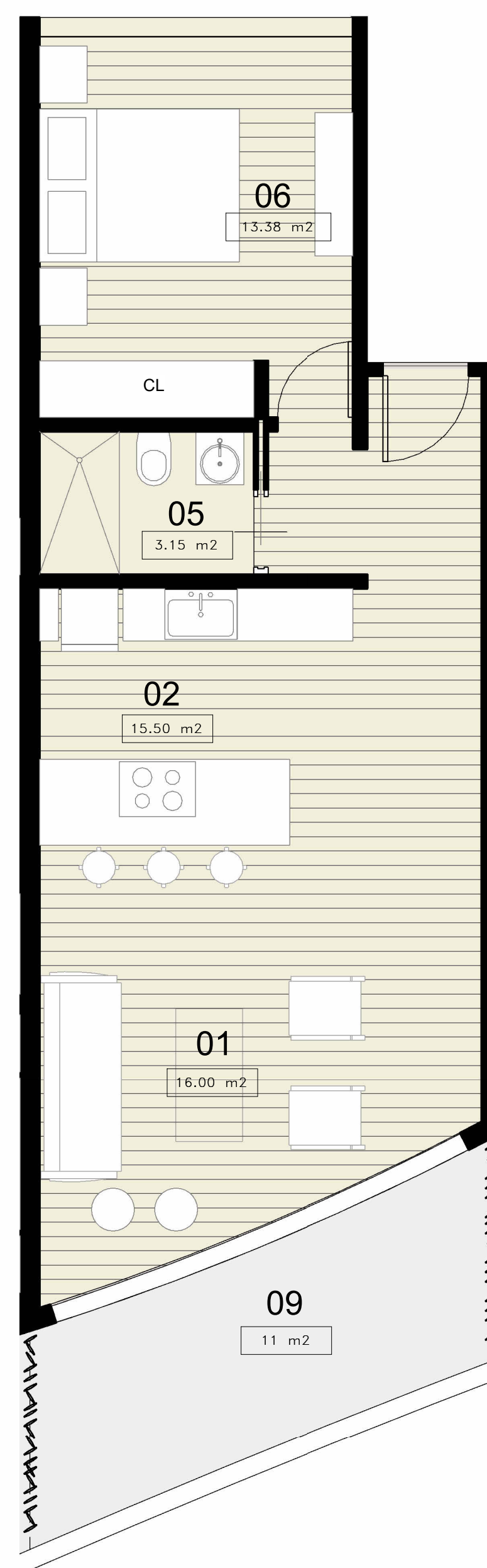

BLOQUE A
APARTAMENTO 105
UNA HABITACION

AREA INTERIOR TOTAL 53 m2
AREA TERRAZA 11 m2
AREA TOTAL 64 m2

SITEPLAN

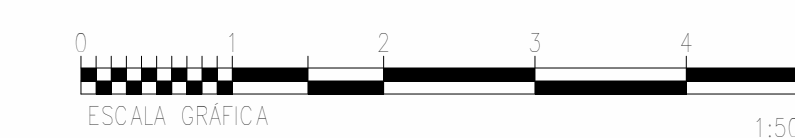
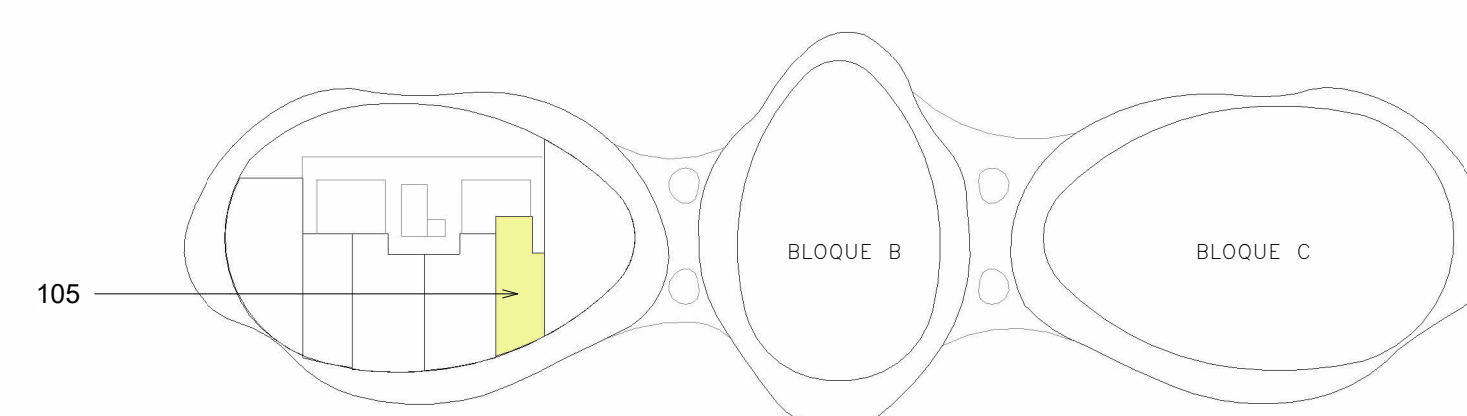

1 Bloque A- apt 105
1 : 50

Norte del proyecto



Proyecto:



LE NID

Bayahibe, La Altagracia
Republica Dominicana

Propietario:

Leyenda

- 01 SALA
- 02 COCINA
- 03 COMEDOR
- 04 HABITACION SECUNDARIA
- 05 BAÑO 1
- 06 HABITACION PRINCIPAL
- 07 LAVADORA-SECADORA
- 08 BAÑO 2
- 09 TERRAZA

Equipo de trabajo

Diseño Arquitectonico:

Arq. Frederich Cedano

Codia:

Arq. Colaboradores:

Arq. Gabriela Moreno

Plano

Apartamento 106 - BLOQUE A

A206

Escala

As indicated

Fecha:

AGOSTO
2024

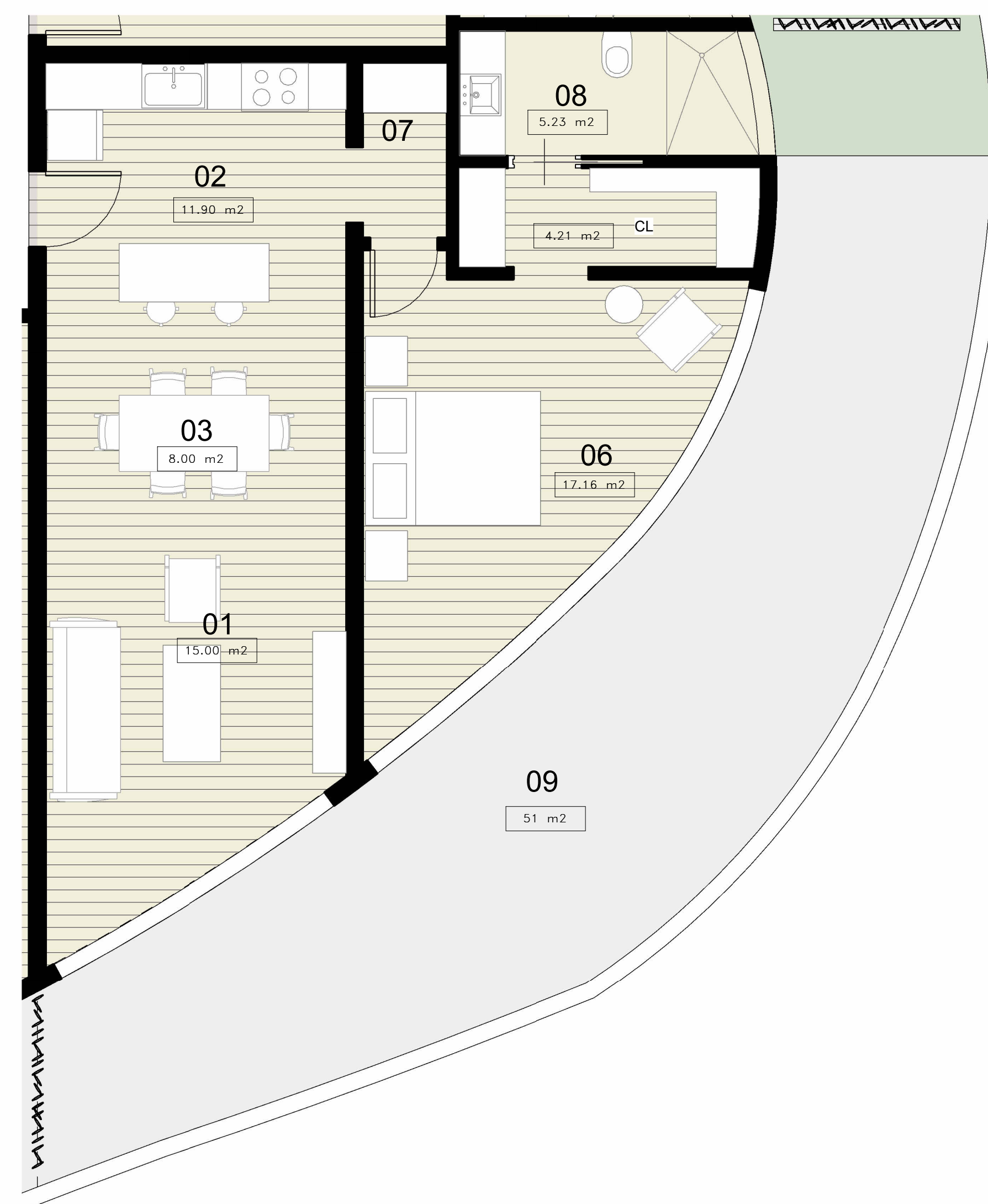

BLOQUE A
APARTAMENTO 106

UNA HABITACION

AREA INTERIOR TOTAL 67 m2

AREA TERRAZA 51 m2

AREA TOTAL 118 m2

SITEPLAN

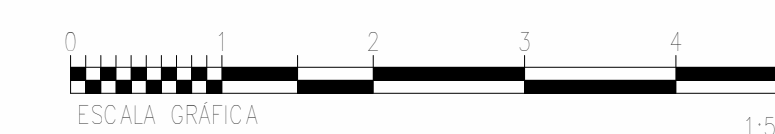
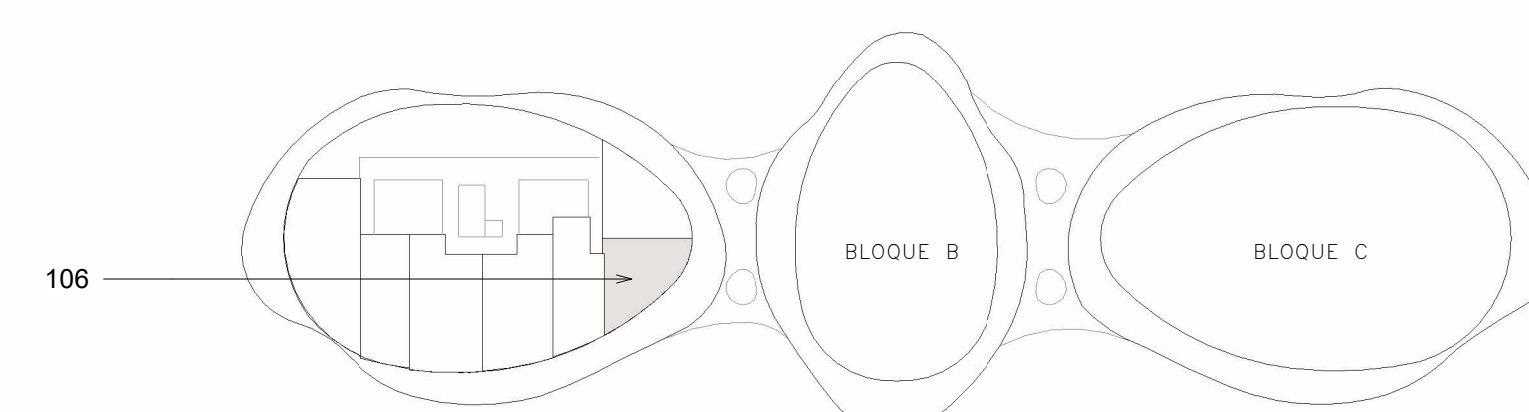

② BLOQUE A- apt 106
1 : 50

Norte del proyecto



Proyecto:



LE NID

Bayahibe, La Altagracia
Republica Dominicana

Propietario:

Leyenda

- 01 SALA
- 02 COCINA
- 03 COMEDOR
- 04 HABITACION SECUNDARIA
- 05 BAÑO 1
- 06 HABITACION PRINCIPAL
- 07 LAVADORA-SECADORA
- 08 BAÑO 2
- 09 TERRAZA

Equipo de trabajo

Diseño Arquitectonico:

Arq. Frederich Cedano

Codia:

Arq. Colaboradores:

Arq. Gabriela Moreno

Plano

Apartamento 107 -BLOQUE A

A207

Escala

As indicated

Fecha:
AGOSTO
2024

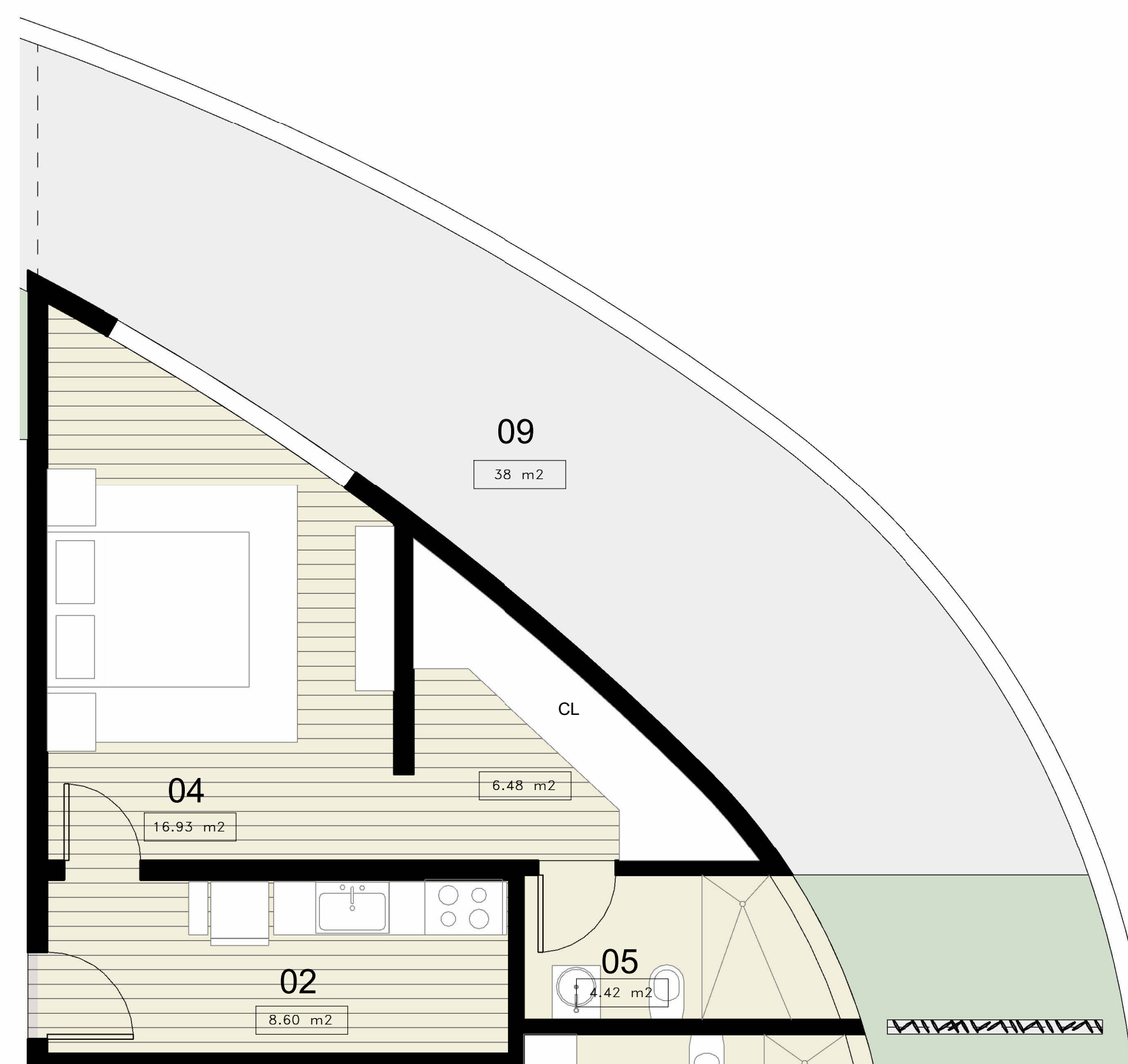

BLOQUE A
APARTAMENTO 107

UNA HABITACION

AREA INTERIOR TOTAL 39 m2

AREA TERRAZA 38 m2

AREA TOTAL 77 m2

SITEPLAN

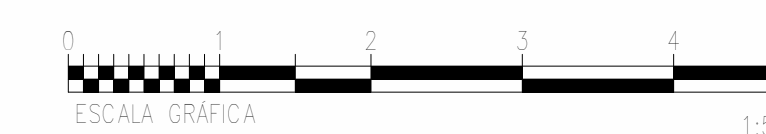
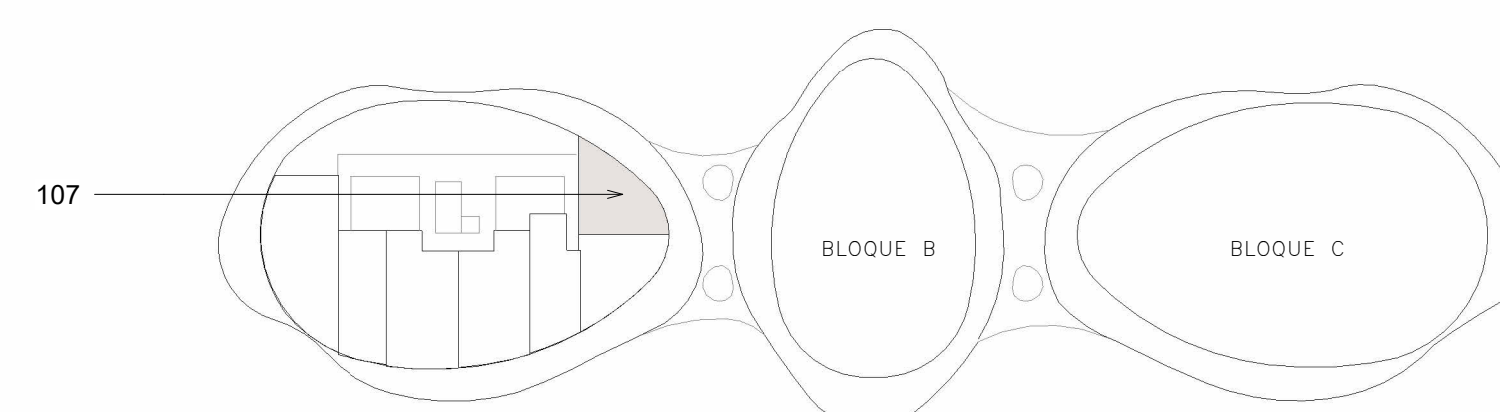

1 BLOQUE A- apt 107
1 : 50

Norte del proyecto



Proyecto:



LE NID

Bayahibe, La Altagracia
Republica Dominicana

Propietario:

Legenda

- 01 SALA
- 02 COCINA
- 03 COMEDOR
- 04 HABITACION SECUNDARIA
- 05 BAÑO 1
- 06 HABITACION PRINCIPAL
- 07 LAVADORA-SECADORA
- 08 BAÑO 2
- 09 TERRAZA

Equipo de trabajo

Diseño Arquitectonico:

Arq. Frederich Cedano

Codia:

Arq. Colaboradores:

Arq. Gabriela Moreno

Plano

Apartamento 201 -BLOQUE A

A208

Escala

As indicated

Fecha:

AGOSTO
2024

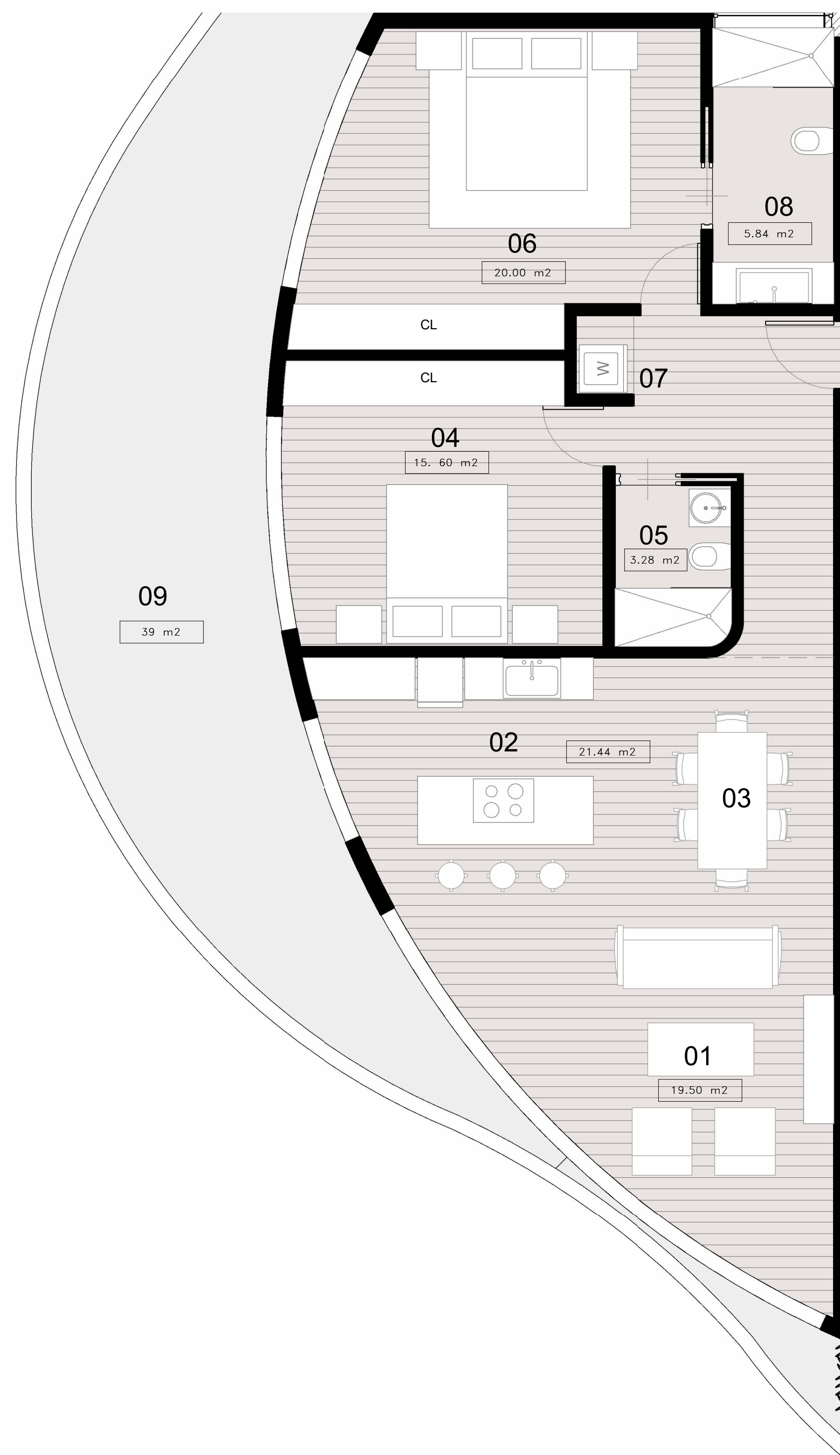

BLOQUE A
APARTAMENTO 201

DOS HABITACIONES

AREA INTERIOR TOTAL 99 m2

AREA TERRAZA 39 m2

AREA TOTAL 138 m2

SITEPLAN

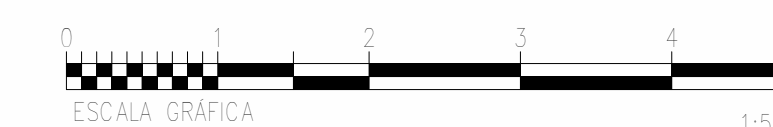
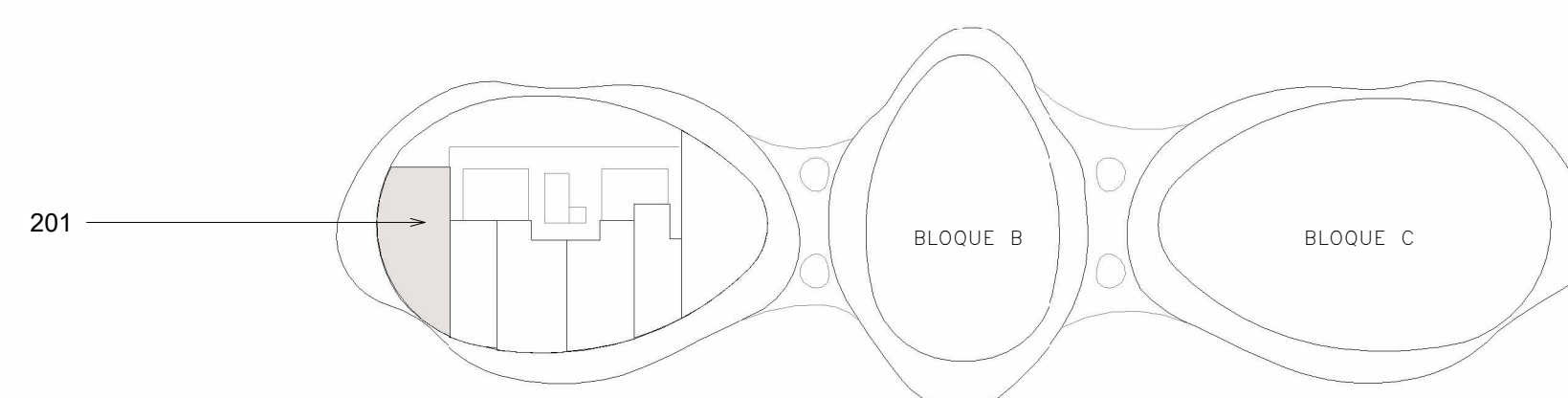

2 Bloque A - apt 201
1 : 50

Norte del proyecto



Proyecto:



LE NID

Bayahibe, La Altagracia
Republica Dominicana

Propietario:

Leyenda

- 01 SALA
- 02 COCINA
- 03 COMEDOR
- 04 HABITACION SECUNDARIA
- 05 BAÑO 1
- 06 HABITACION PRINCIPAL
- 07 LAVADORA-SECADORA
- 08 BAÑO 2
- 09 TERRAZA

Equipo de trabajo

Diseño Arquitectonico:

Arq. Frederich Cedano

Codia:

Arq. Colaboradores:

Arq. Gabriela Moreno

Plano

Apartamento 202-BLOQUE A

A209

Escala

As indicated

Fecha:

AGOSTO
2024

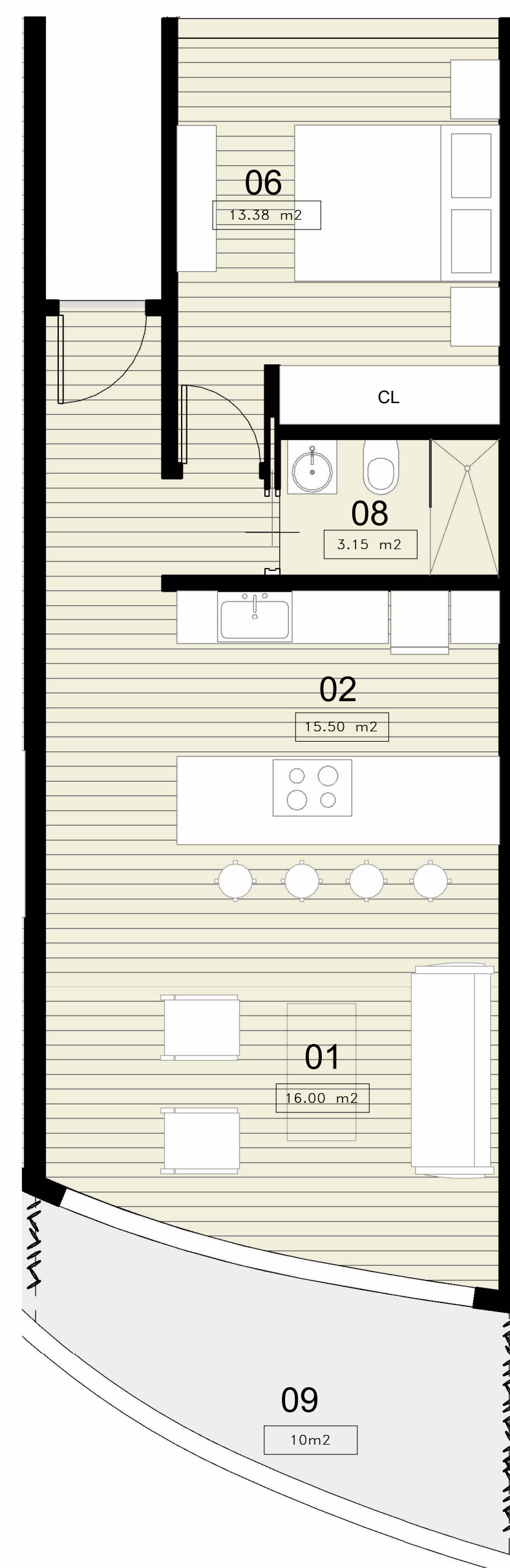

BLOQUE A
APARTAMENTO 202

UNA HABITACION

AREA INTERIOR TOTAL 54 m2

AREA TERRAZA 10 m2

AREA TOTAL 64 m2

SITEPLAN

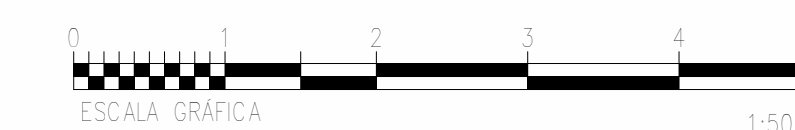
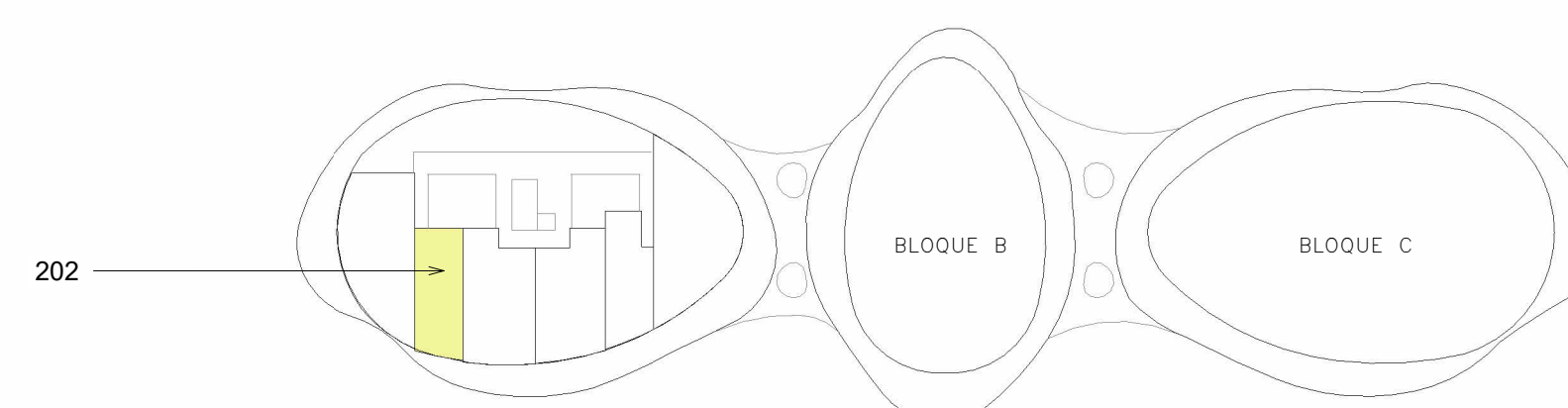

① Bloque A-apt 202
1 : 50

Norte del proyecto



Proyecto:



LE NID

Bayahibe, La Altagracia
Republica Dominicana

Propietario:

Leyenda

- 01 SALA
- 02 COCINA
- 03 COMEDOR
- 04 HABITACION SECUNDARIA
- 05 BAÑO 1
- 06 HABITACION PRINCIPAL
- 07 LAVADORA-SECADORA
- 08 BAÑO 2
- 09 TERRAZA

Equipo de trabajo

Diseño Arquitectonico:

Arq. Frederich Cedano

Codia:

Arq. Colaboradores:

Arq. Gabriela Moreno

Plano

Apartamento 204 -BLOQUE A

A210

Escala

As indicated

Fecha:

AGOSTO
2024

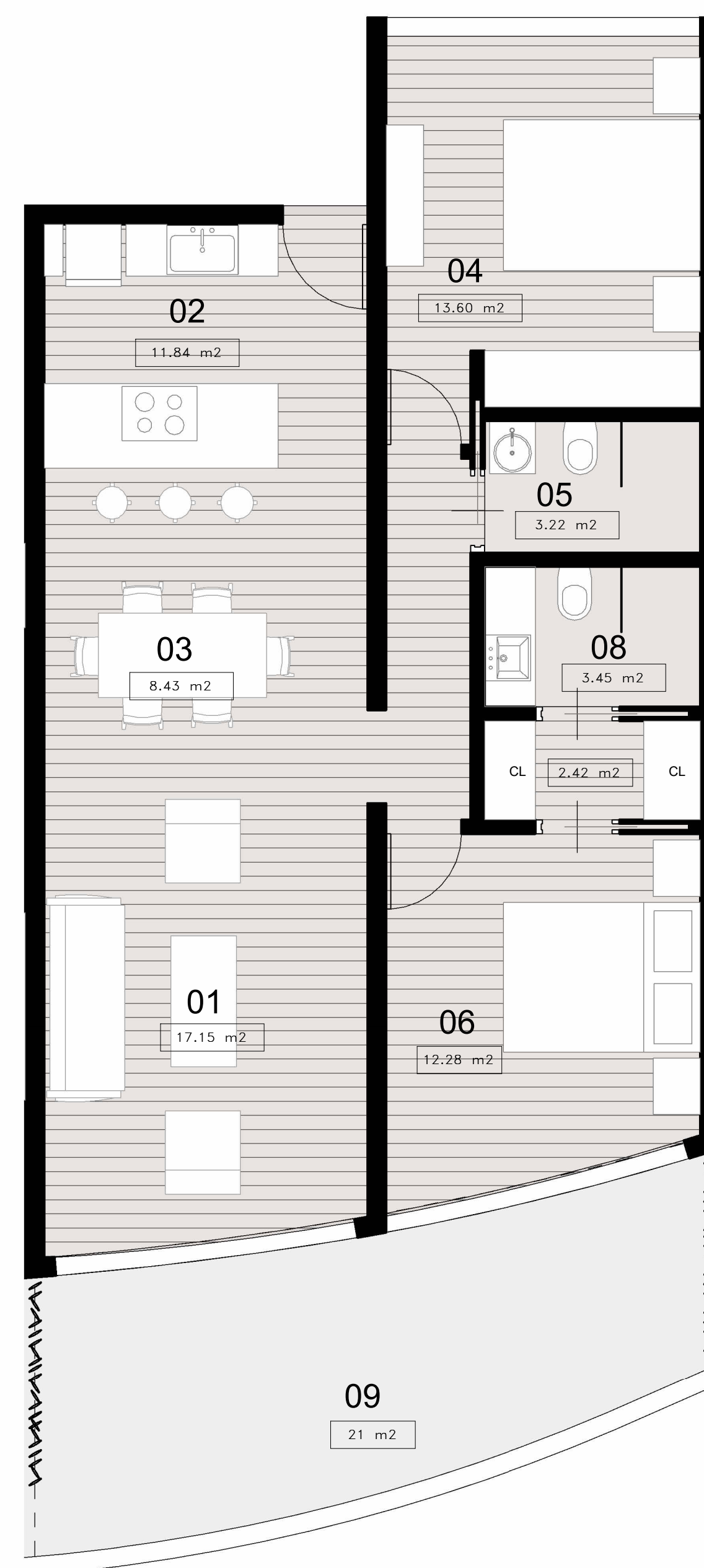

BLOQUE A
APARTAMENTO 204

DOS HABITACIONES

AREA INTERIOR TOTAL 80 m2

AREA TERRAZA 21 m2

AREA TOTAL 101 m2

SITEPLAN

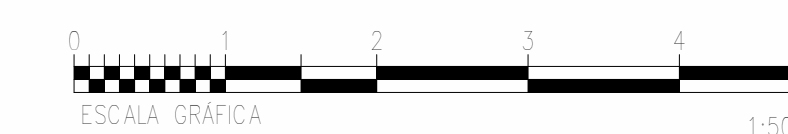
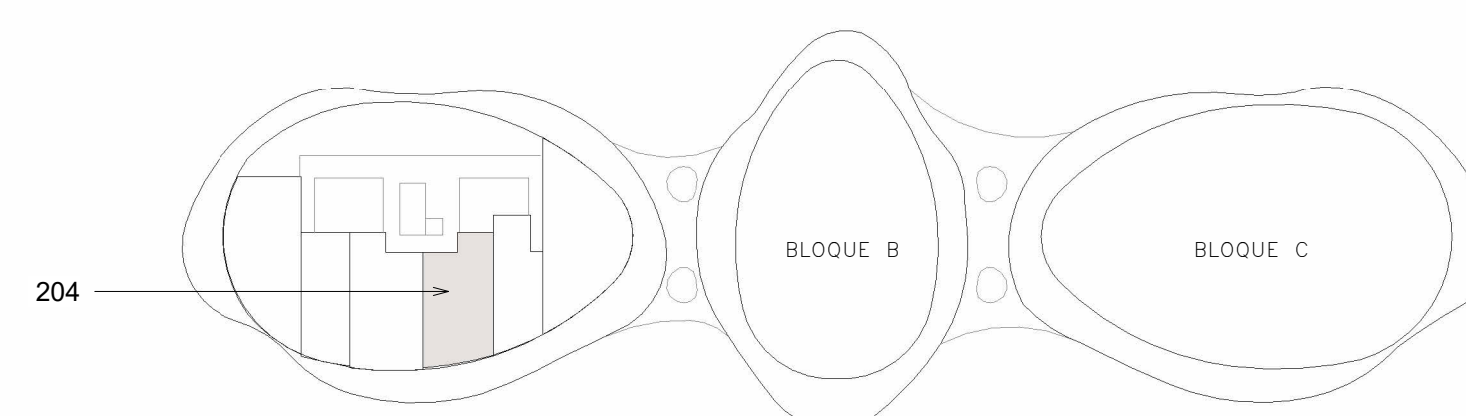

① Bloque A- apt 204
1 : 50

Norte del proyecto



Proyecto:



LE NID

Bayahibe, La Altagracia
Republica Dominicana

Propietario:

Leyenda

- 01 SALA
- 02 COCINA
- 03 COMEDOR
- 04 HABITACION SECUNDARIA
- 05 BAÑO 1
- 06 HABITACION PRINCIPAL
- 07 LAVADORA-SECADORA
- 08 BAÑO 2
- 09 TERRAZA

Equipo de trabajo

Diseño Arquitectonico:

Arq. Frederich Cedano

Codia:

Arq. Colaboradores:

Arq. Gabriela Moreno

Plano

Apartamento 205 -BLOQUE A

A211

Escala

As indicated

Fecha:
AGOSTO
2024

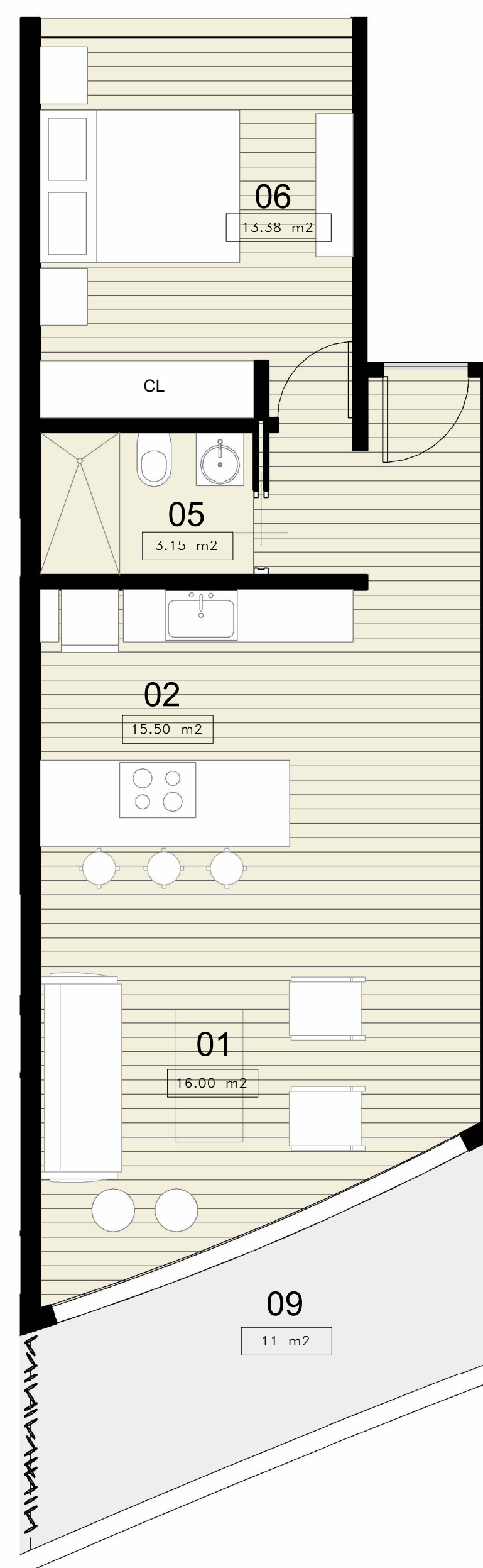

BLOQUE A
APARTAMENTO 205

UNA HABITACION

AREA INTERIOR TOTAL 53 m2

AREA TERRAZA 11 m2

AREA TOTAL 64 m2

SITEPLAN

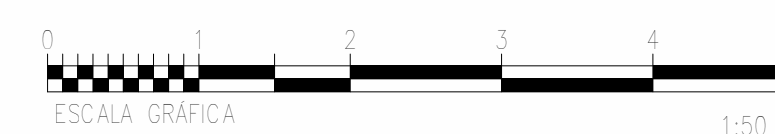
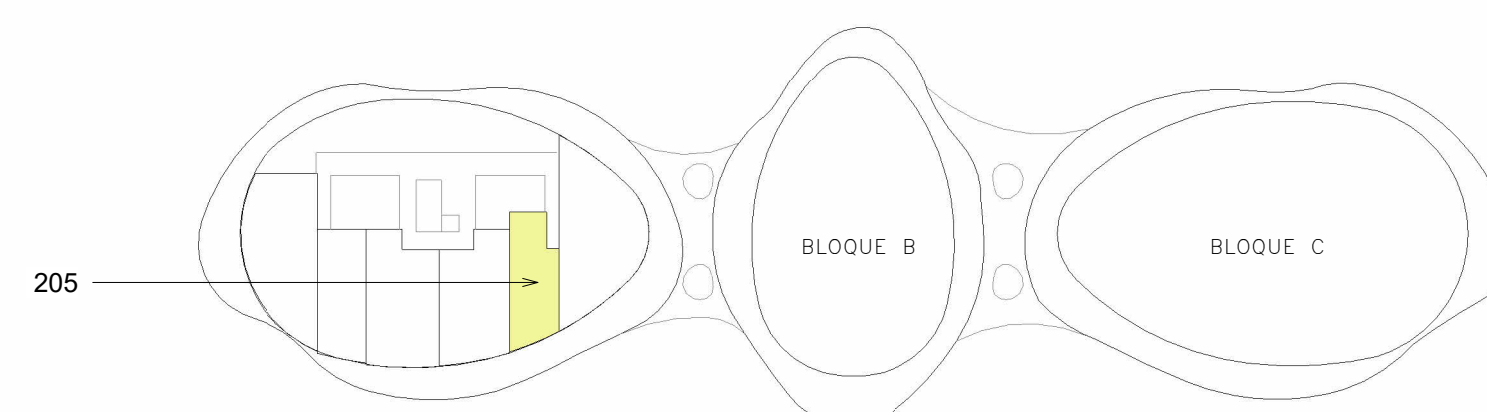

① Bloque A- apt 205
1 : 50

Norte del proyecto



Proyecto:



LE NID

Bayahibe, La Altagracia
Republica Dominicana

Propietario:

Leyenda

- 01 SALA
- 02 COCINA
- 03 COMEDOR
- 04 HABITACION SECUNDARIA
- 05 BAÑO 1
- 06 HABITACION PRINCIPAL
- 07 LAVADORA-SECADORA
- 08 BAÑO 2
- 09 TERRAZA

Equipo de trabajo

Diseño Arquitectonico:

Arq. Frederich Cedano

Codia:

Arq. Colaboradores:

Arq. Gabriela Moreno

Plano

Apartamento 206-BLOQUE A

A212

Escala

As indicated

Fecha:

AGOSTO
2024

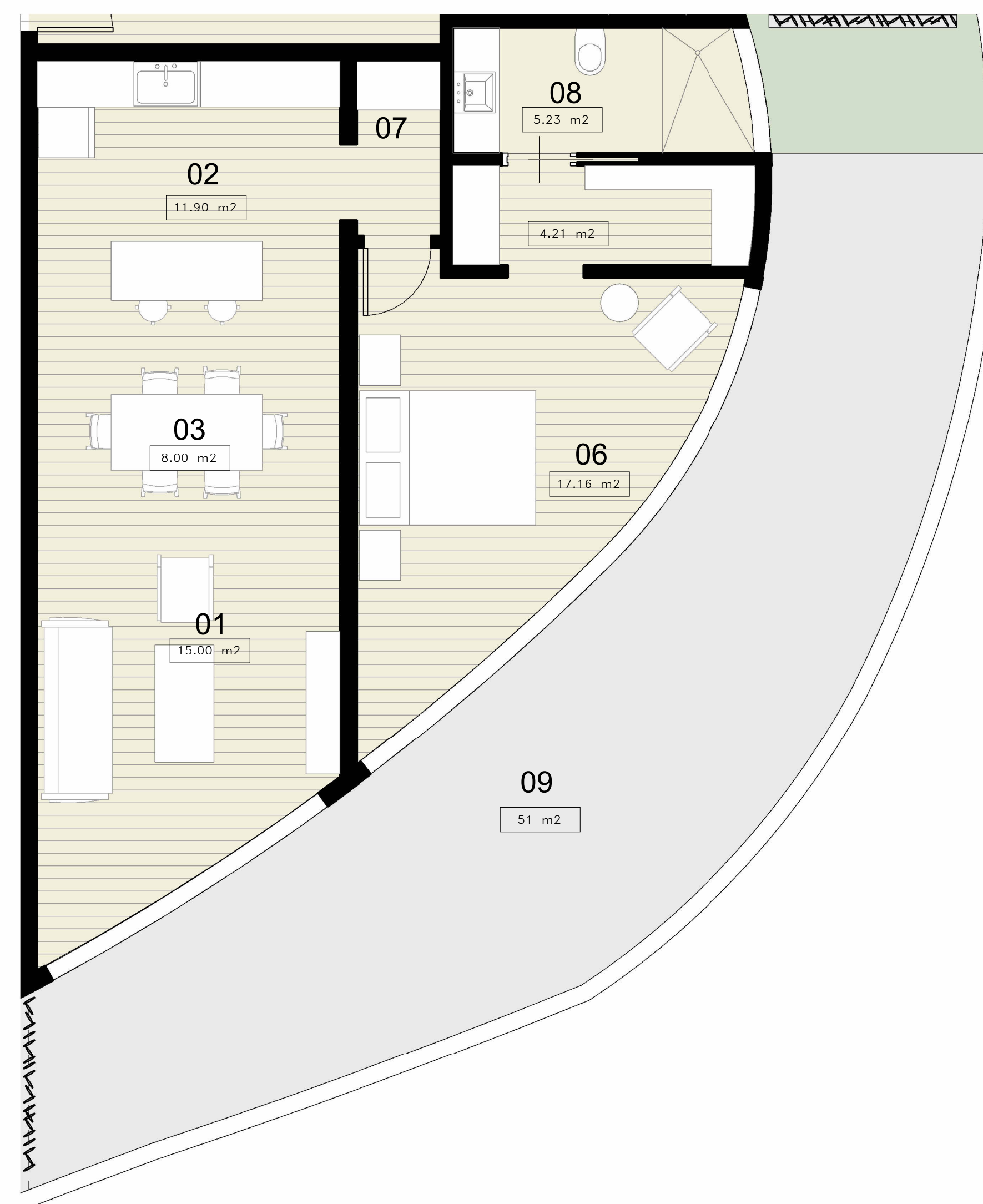

BLOQUE A
APARTAMENTO 206

UNA HABITACION

AREA INTERIOR TOTAL 66 m2

AREA TERRAZA 51 m2

AREA TOTAL 117 m2

SITEPLAN

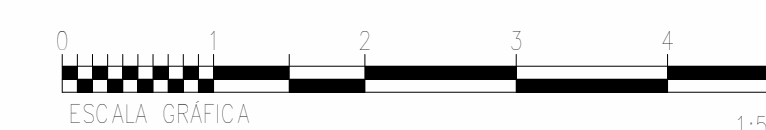
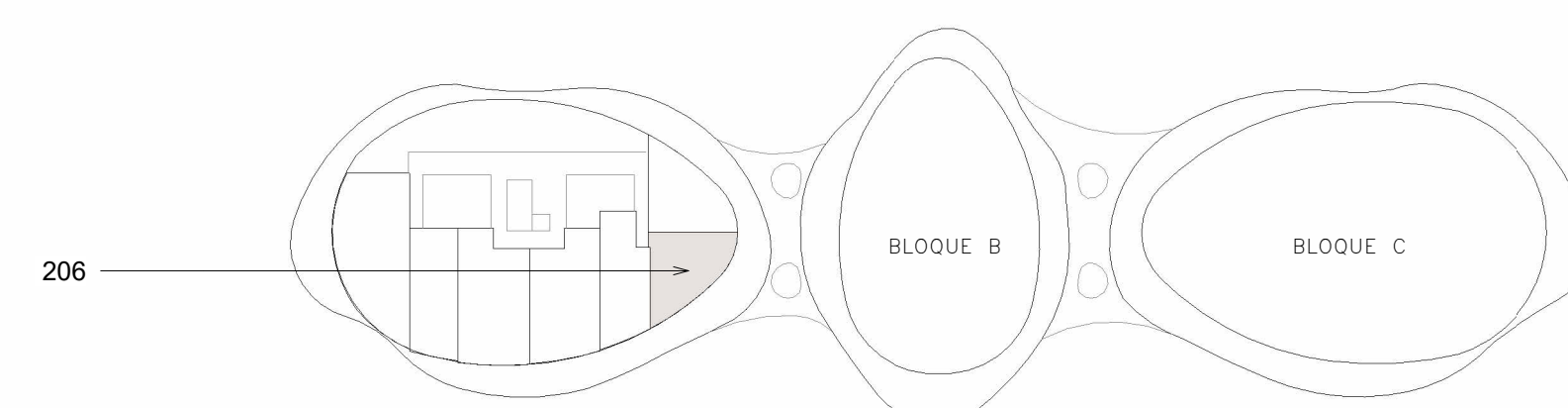

1 BLOQUE A- apt 206
1:50

Norte del proyecto



Proyecto:



LE NID

Bayahibe, La Altagracia
Republica Dominicana

Propietario:

Leyenda

- 01 SALA
- 02 COCINA
- 03 COMEDOR
- 04 HABITACION SECUNDARIA
- 05 BAÑO 1
- 06 HABITACION PRINCIPAL
- 07 LAVADORA-SECADORA
- 08 BAÑO 2
- 09 TERRAZA

Equipo de trabajo

Diseño Arquitectonico:

Arq. Frederich Cedano

Codia:

Arq. Colaboradores:

Arq. Gabriela Moreno

Plano

Apartamento 207-BLOQUE A

A213

Escala

As indicated

Fecha:

AGOSTO
2024

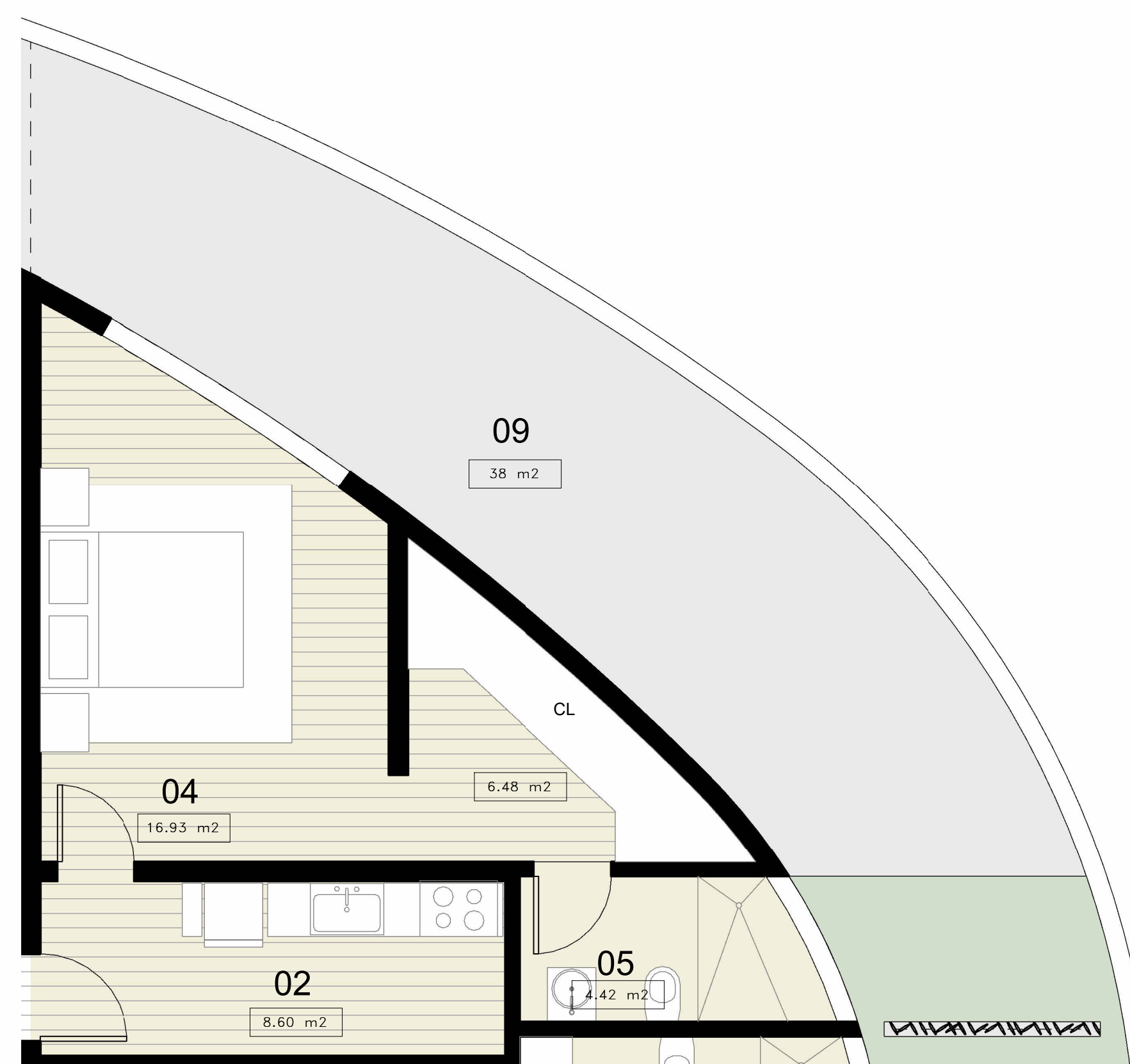

BLOQUE A
APARTAMENTO 207

UNA HABITACION

AREA INTERIOR TOTAL 66 m2

AREA TERRAZA 51 m2

AREA TOTAL 117 m2

SITEPLAN

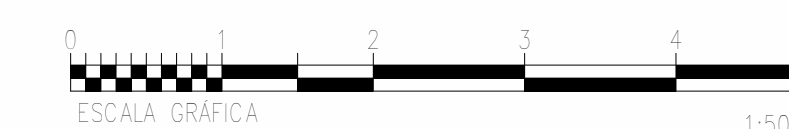
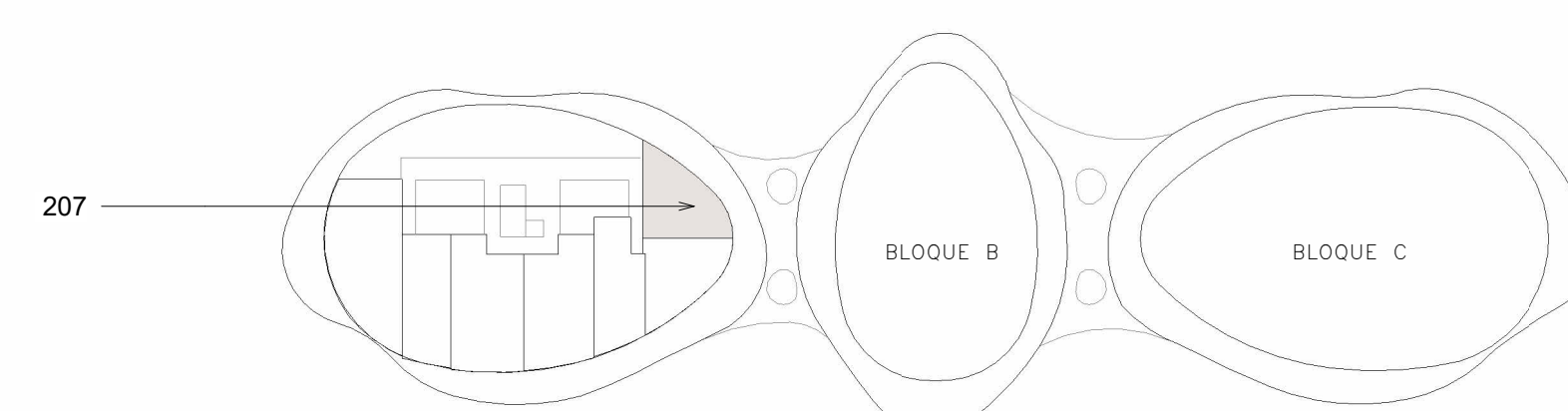

② BLOQUE A- apt 207
1:50

Norte del proyecto



Proyecto:



LE NID

Bayahibe, La Altagracia
Republica Dominicana

Propietario:

Leyenda

- 01 SALA
- 02 COCINA
- 03 COMEDOR
- 04 HABITACION SECUNDARIA
- 05 BAÑO 1
- 06 HABITACION PRINCIPAL
- 07 LAVADORA-SECADORA
- 08 BAÑO 2
- 09 TERRAZA

Equipo de trabajo

Diseño Arquitectonico:

Arq. Frederich Cedano

Codia:

Arq. Colaboradores:

Arq. Gabriela Moreno

Plano

Apartamento 208 -BLOQUE A

A214

Escala

As indicated

Fecha:

AGOSTO
2024

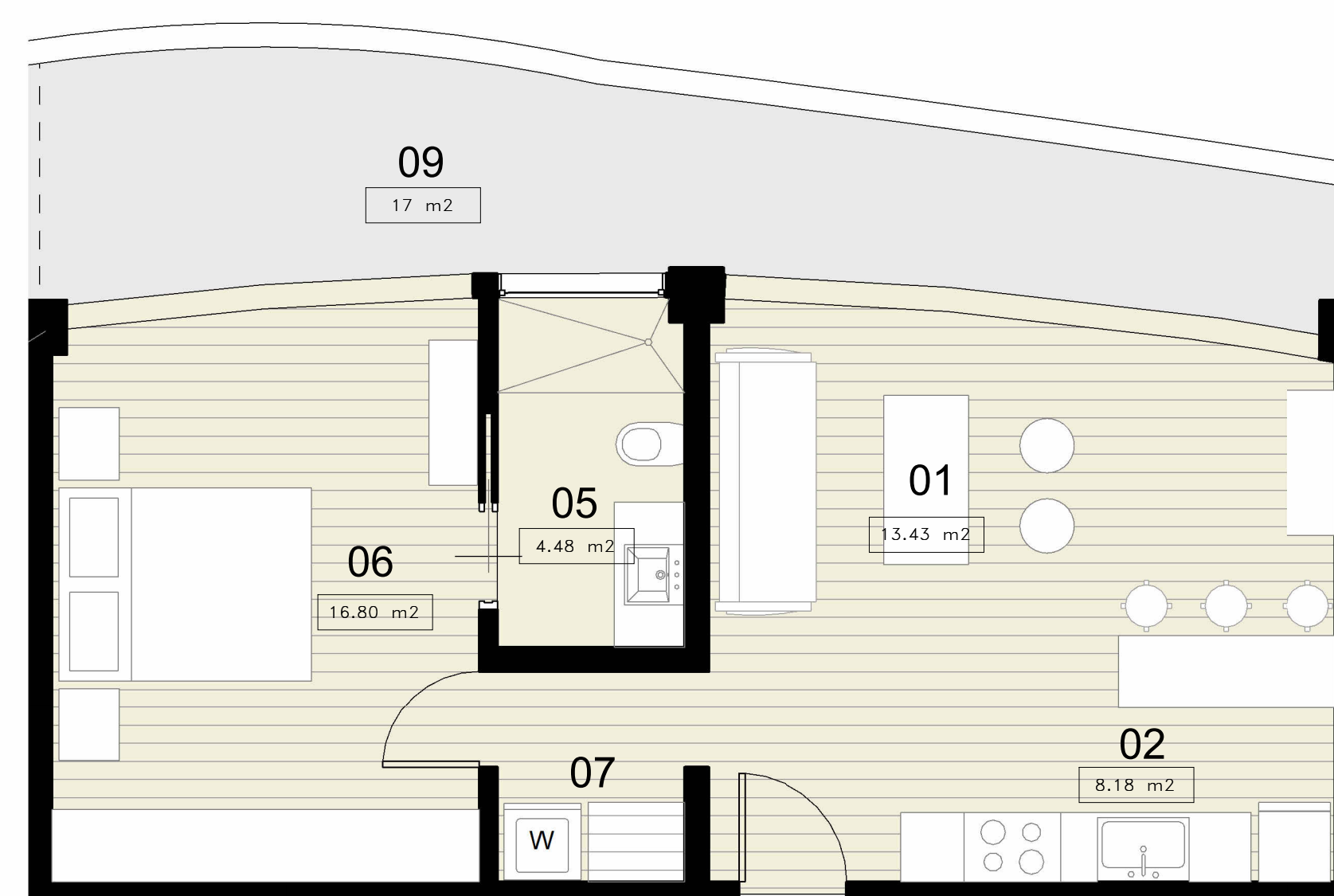

BLOQUE A
APARTAMENTO 208
UNA HABITACION

AREA INTERIOR TOTAL 51 m2
AREA TERRAZA 17 m2
AREA TOTAL 68 m2

SITEPLAN

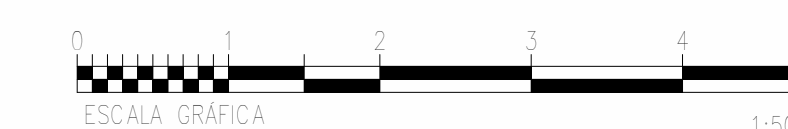
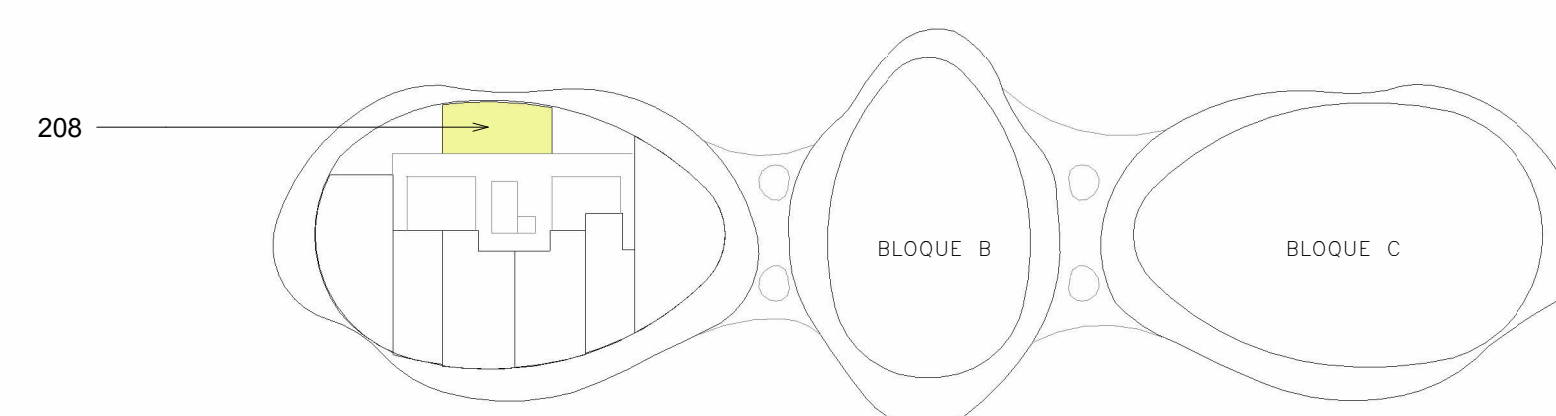

② Bloque A- apt 208
1 : 50

Norte del proyecto



Proyecto:



LE NID

Bayahibe, La Altagracia
Republica Dominicana

Propietario:

Leyenda

- 01 SALA
- 02 COCINA
- 03 COMEDOR
- 04 HABITACION SECUNDARIA
- 05 BAÑO 1
- 06 HABITACION PRINCIPAL
- 07 LAVADORA-SECADORA
- 08 BAÑO 2
- 09 TERRAZA

Equipo de trabajo

Diseño Arquitectonico:

Arq. Frederich Cedano

Codia:

Arq. Colaboradores:

Arq. Gabriela Moreno

Plano

Apartamento 301-BLOQUE A

A215

Escala

As indicated

Fecha:
AGOSTO
2024

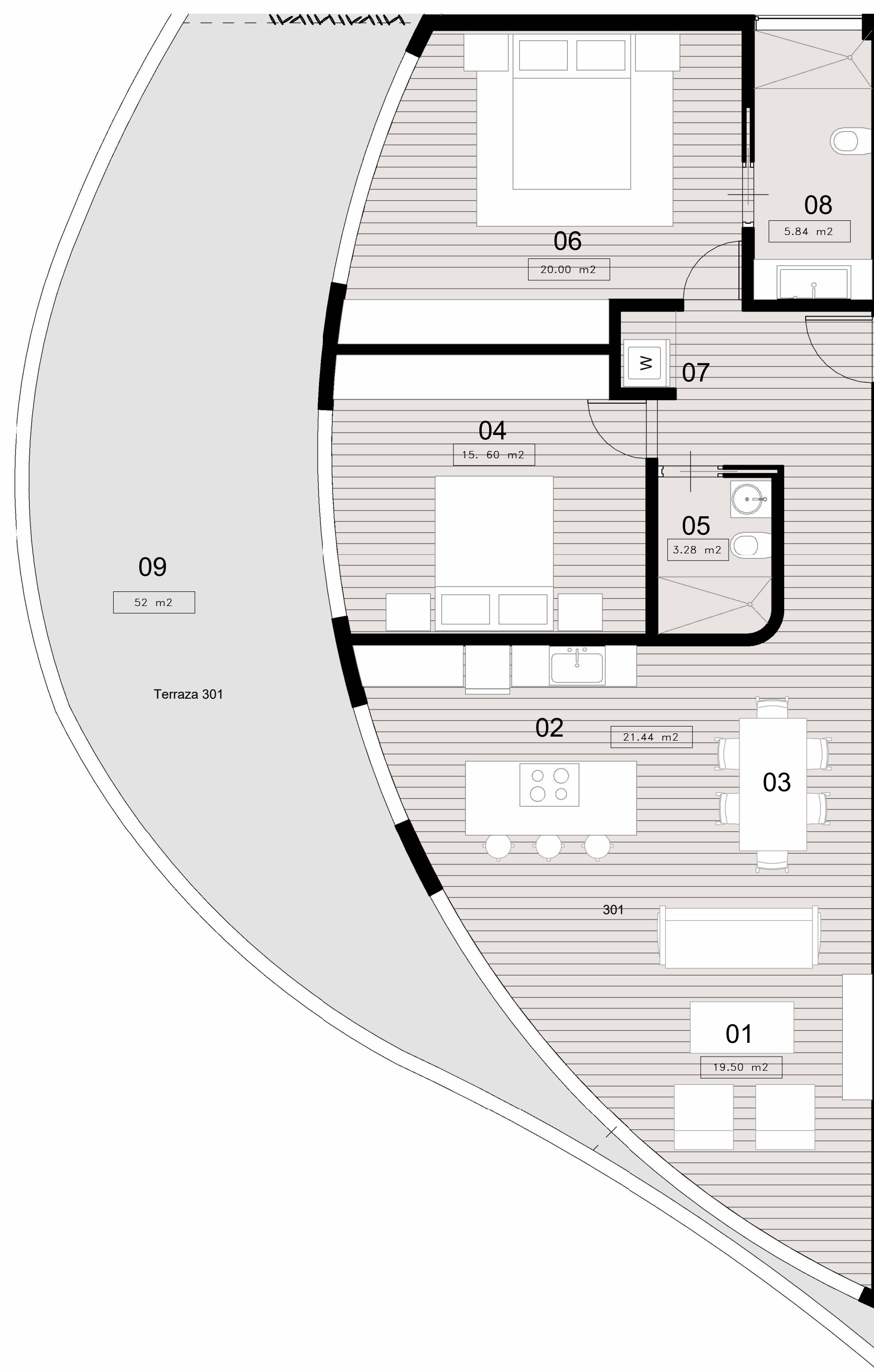

BLOQUE A
APARTAMENTO 301

DOS HABITACIONES

AREA INTERIOR TOTAL 99 m2

AREA TERRAZA 52 m2

AREA TOTAL 151 m2

SITEPLAN

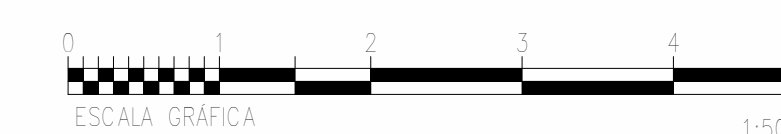
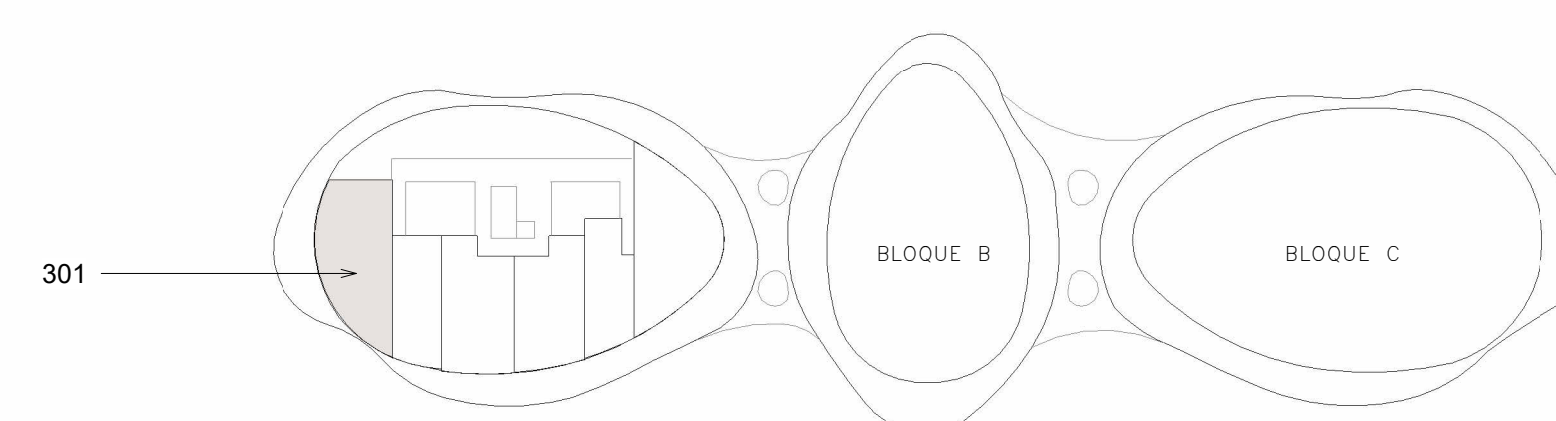

① BLOQUE A- apt 301
1: 50

Norte del proyecto



Proyecto:



LE NID

Bayahibe, La Altagracia
Republica Dominicana

Propietario:

Leyenda

- 01 SALA
- 02 COCINA
- 03 COMEDOR
- 04 HABITACION SECUNDARIA
- 05 BAÑO 1
- 06 HABITACION PRINCIPAL
- 07 LAVADORA-SECADORA
- 08 BAÑO 2
- 09 TERRAZA

Equipo de trabajo

Diseño Arquitectonico:

Arq. Frederich Cedano

Codia:

Arq. Colaboradores:

Arq. Gabriela Moreno

Plano

Apartamento 302-BLOQUE A

A216

Escala

As indicated

Fecha:

AGOSTO
2024

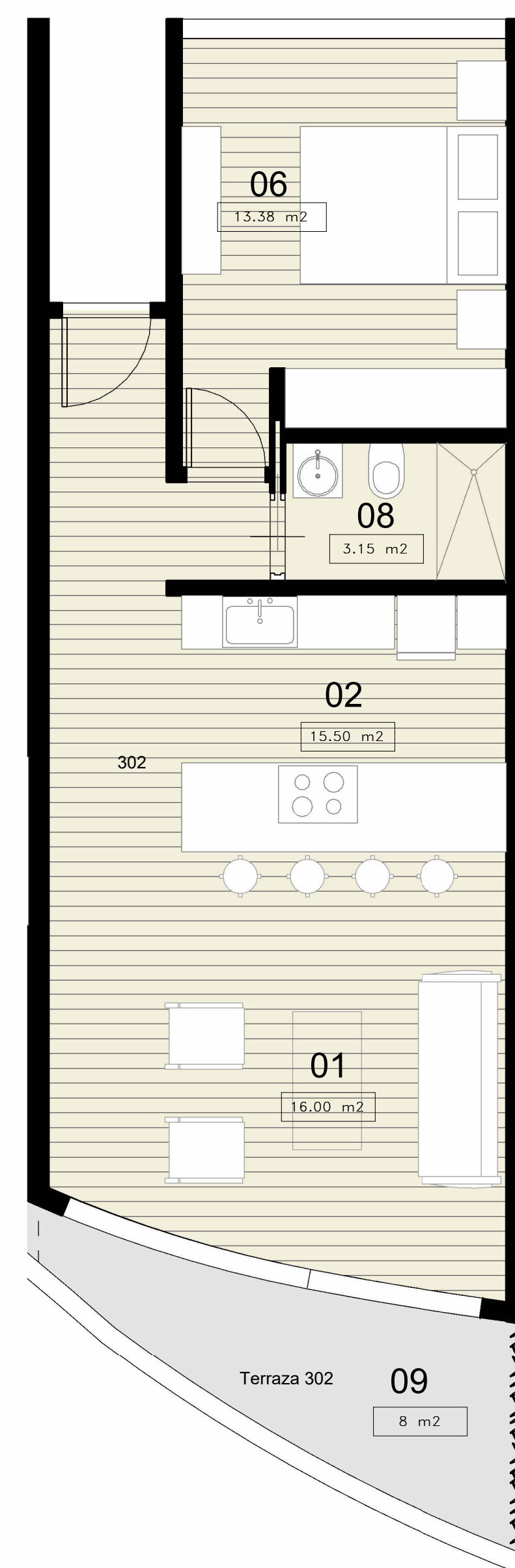

BLOQUE A
APARTAMENTO 302

UNA HABITACION

AREA INTERIOR TOTAL 54 m2

AREA TERRAZA 8 m2

AREA TOTAL 62 m2

SITEPLAN

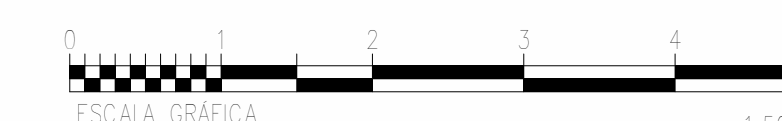
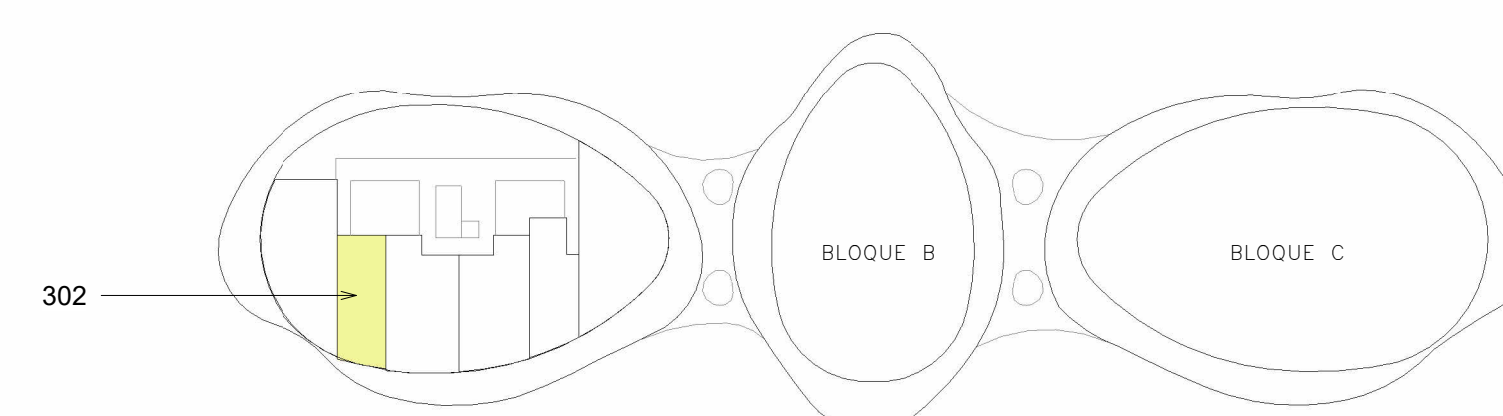

① BLOQUE A- apt 302
1:50

Norte del proyecto



Proyecto:



Bayahibe, La Altagracia
Republica Dominicana

Propietario:

Leyenda

- 01 SALA
- 02 COCINA
- 03 COMEDOR
- 04 HABITACION SECUNDARIA
- 05 BAÑO 1
- 06 HABITACION PRINCIPAL
- 07 LAVADORA-SECADORA
- 08 BAÑO 2
- 09 TERRAZA

Equipo de trabajo

Diseño Arquitectonico:

Arq. Frederich Cedano

Codia:

Arq. Colaboradores:

Arq. Gabriela Moreno

Plano

Apartamento 303 - BLOQUE A

A217

Escala

As indicated

Fecha:

AGOSTO
2024

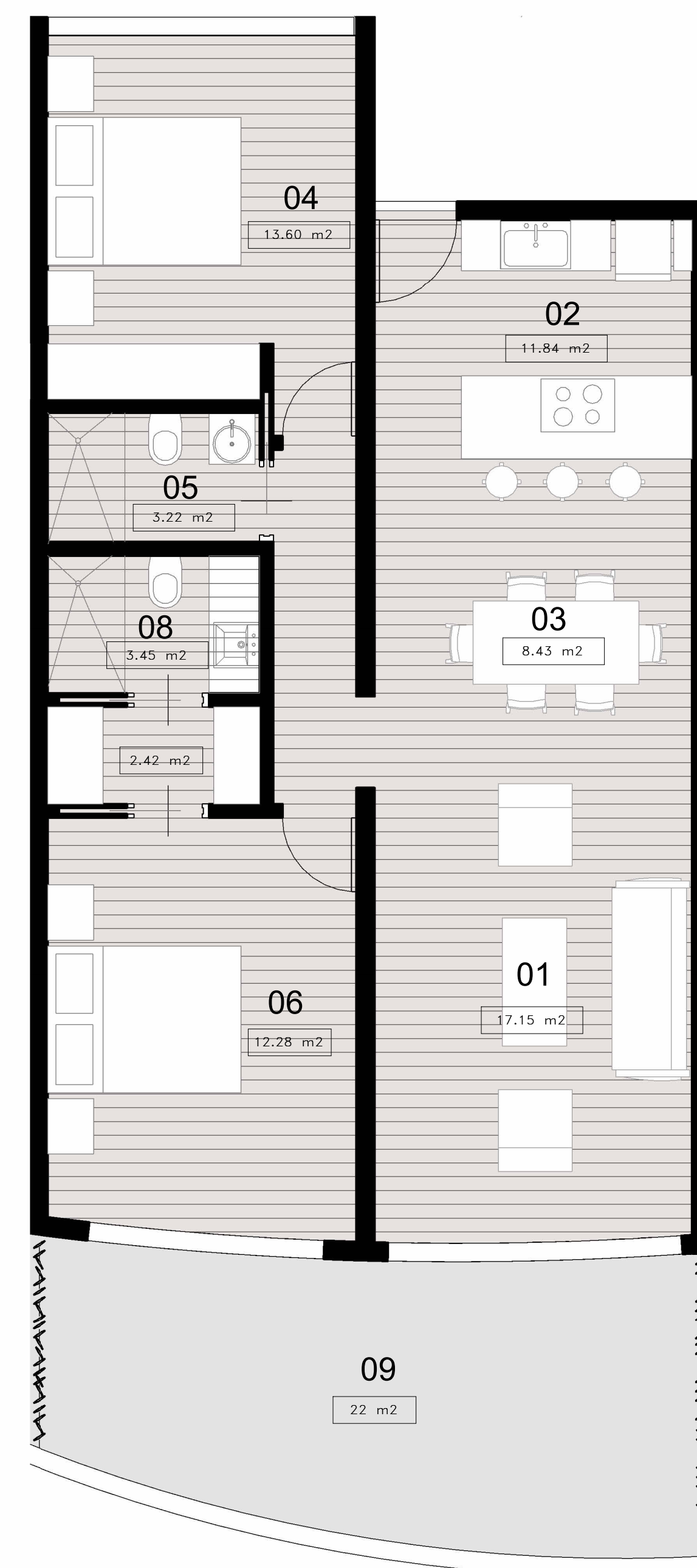

BLOQUE A
APARTAMENTO 303

DOS HABITACIONES

AREA INTERIOR TOTAL 84 m2

AREA TERRAZA 22 m2

AREA TOTAL 106 m2

SITEPLAN

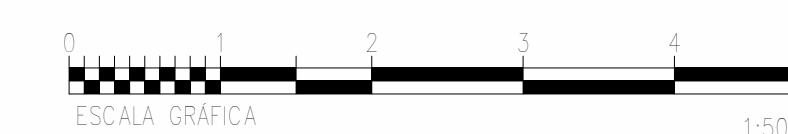
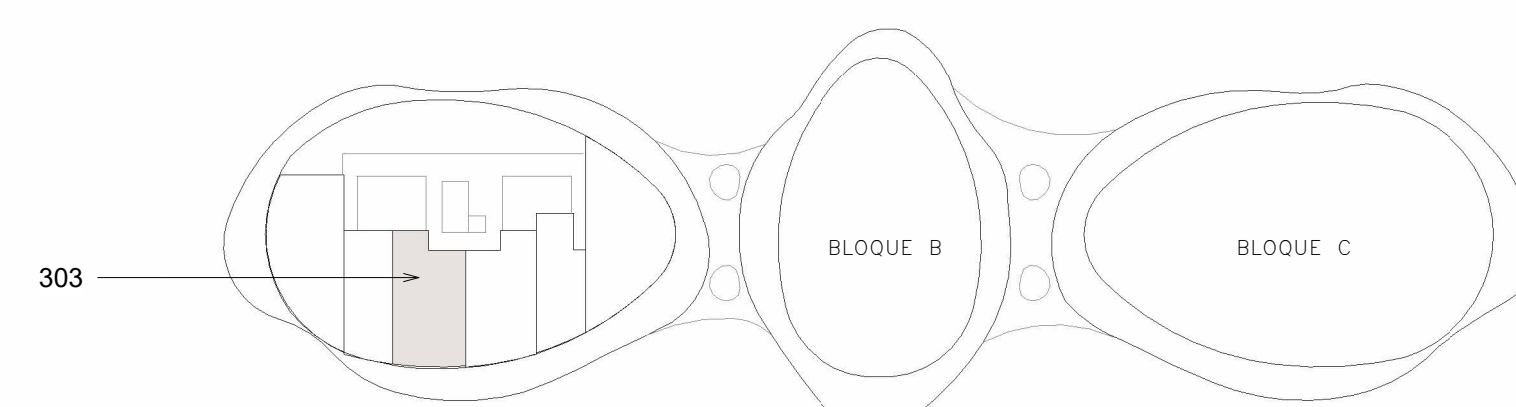

1 Bloque A- apt 303
1:50

Norte del proyecto



Proyecto:



LE NID

Bayahibe, La Altagracia
Republica Dominicana

Propietario:

Leyenda

- 01 SALA
- 02 COCINA
- 03 COMEDOR
- 04 HABITACION SECUNDARIA
- 05 BAÑO 1
- 06 HABITACION PRINCIPAL
- 07 LAVADORA-SECADORA
- 08 BAÑO 2
- 09 TERRAZA

Equipo de trabajo

Diseño Arquitectonico:

Arq. Frederich Cedano

Codia:

Arq. Colaboradores:

Arq. Gabriela Moreno

Plano

Apartamento 304-BLOQUE A

A218

Escala

As indicated

Fecha:

AGOSTO
2024

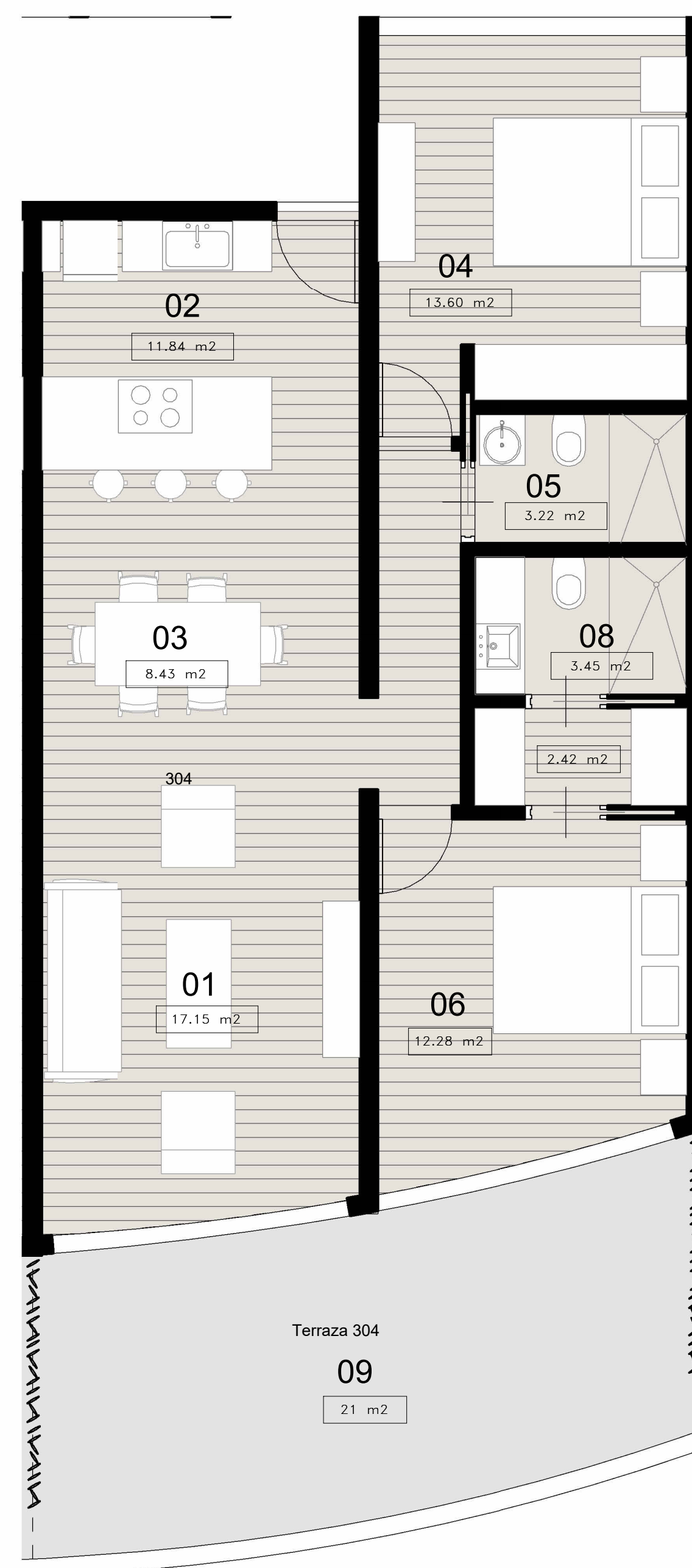

BLOQUE A
APARTAMENTO 304

DOS HABITACIONES

AREA INTERIOR TOTAL 81 m2

AREA TERRAZA 25 m2

AREA TOTAL 106 m2

SITEPLAN

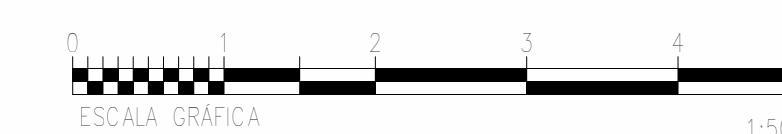
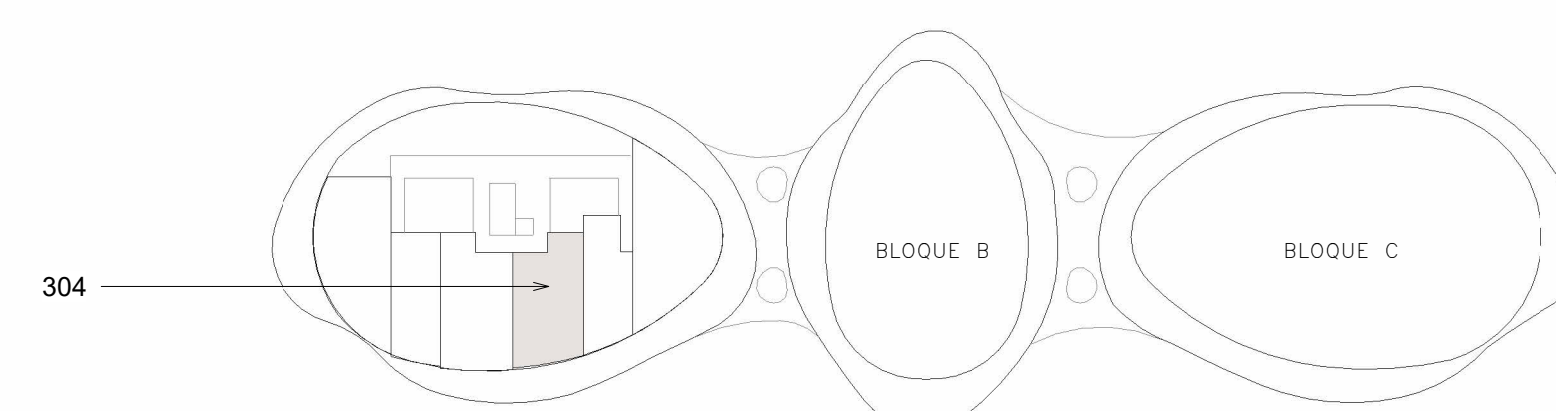

1 BLOQUE A- apt 304
1 : 50

Norte del proyecto



Proyecto:



LE NID

Bayahibe, La Altagracia
Republica Dominicana

Propietario:

Leyenda

- 01 SALA
- 02 COCINA
- 03 COMEDOR
- 04 HABITACION SECUNDARIA
- 05 BAÑO 1
- 06 HABITACION PRINCIPAL
- 07 LAVADORA-SECADORA
- 08 BAÑO 2
- 09 TERRAZA

Equipo de trabajo

Diseño Arquitectonico:

Arq. Frederich Cedano

Codia:

Arq. Colaboradores:

Arq. Gabriela Moreno

Plano

Apartamento 305-BLOQUE A

A219

Escala

As indicated

Fecha:
AGOSTO
2024

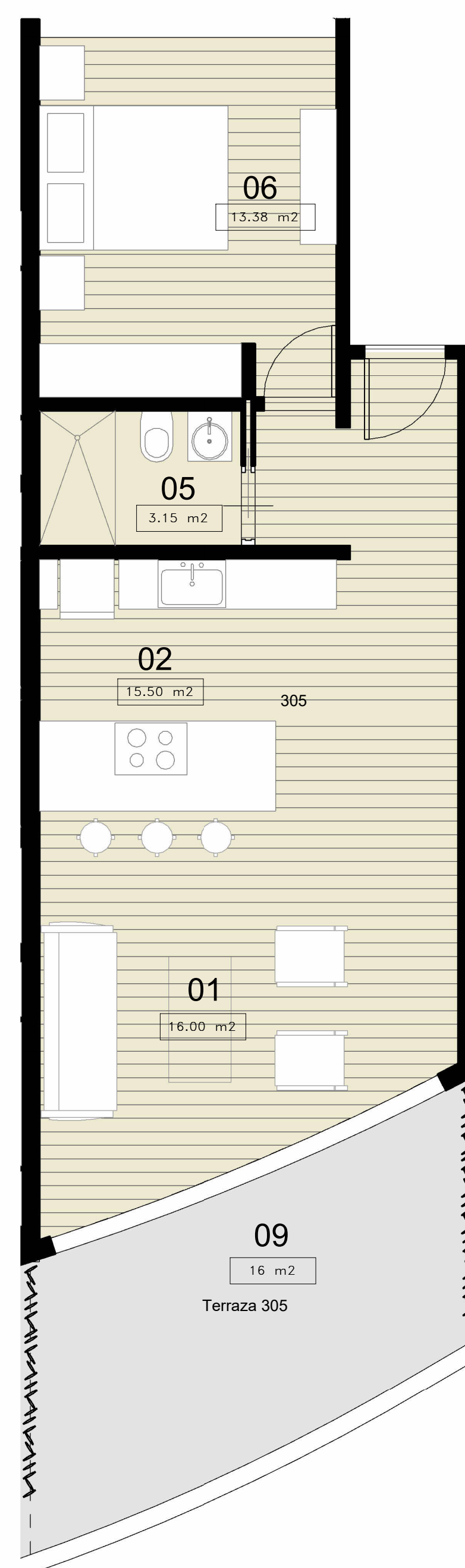

BLOQUE A
APARTAMENTO 305

UNA HABITACION

AREA INTERIOR TOTAL 53 m2

AREA TERRAZA 16 m2

AREA TOTAL 69 m2

SITEPLAN

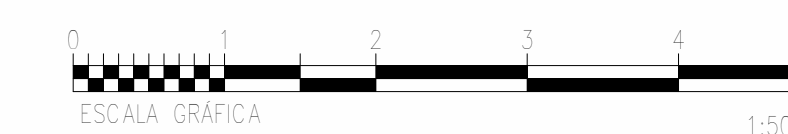
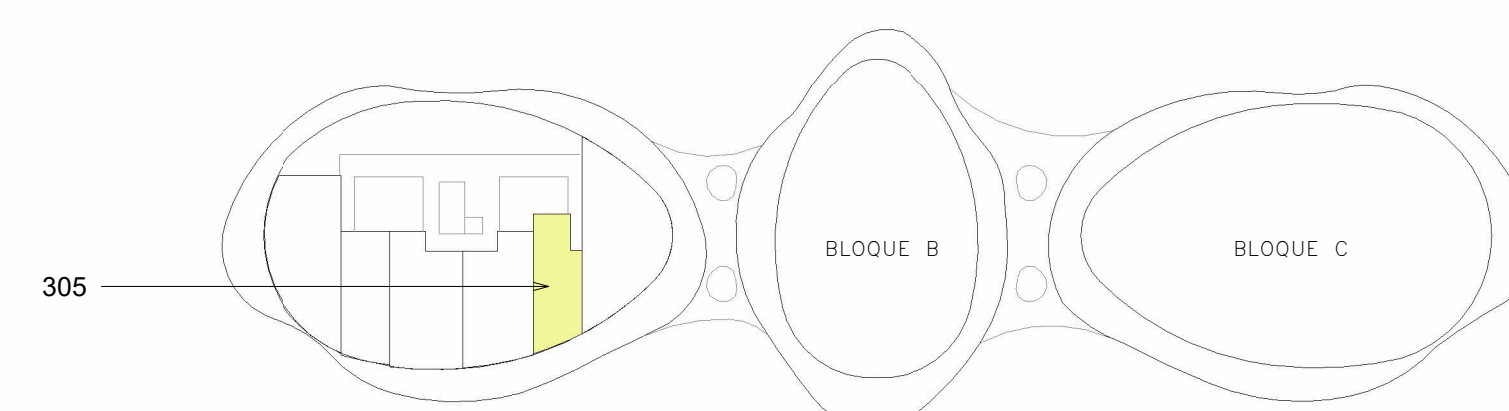

1 BLOQUE A- apt 305
1 : 50

Norte del proyecto



Proyecto:



LE NID

Bayahibe, La Altagracia
Republica Dominicana

Propietario:

Leyenda

- 01 SALA
- 02 COCINA
- 03 COMEDOR
- 04 HABITACION SECUNDARIA
- 05 BAÑO 1
- 06 HABITACION PRINCIPAL
- 07 LAVADORA-SECADORA
- 08 BAÑO 2
- 09 TERRAZA

Equipo de trabajo

Diseño Arquitectonico:

Arq. Frederich Cedano

Codia:

Arq. Colaboradores:

Arq. Gabriela Moreno

Plano

Apartamento 306-BLOQUE A

A220

Escala

As indicated

Fecha:

AGOSTO
2024

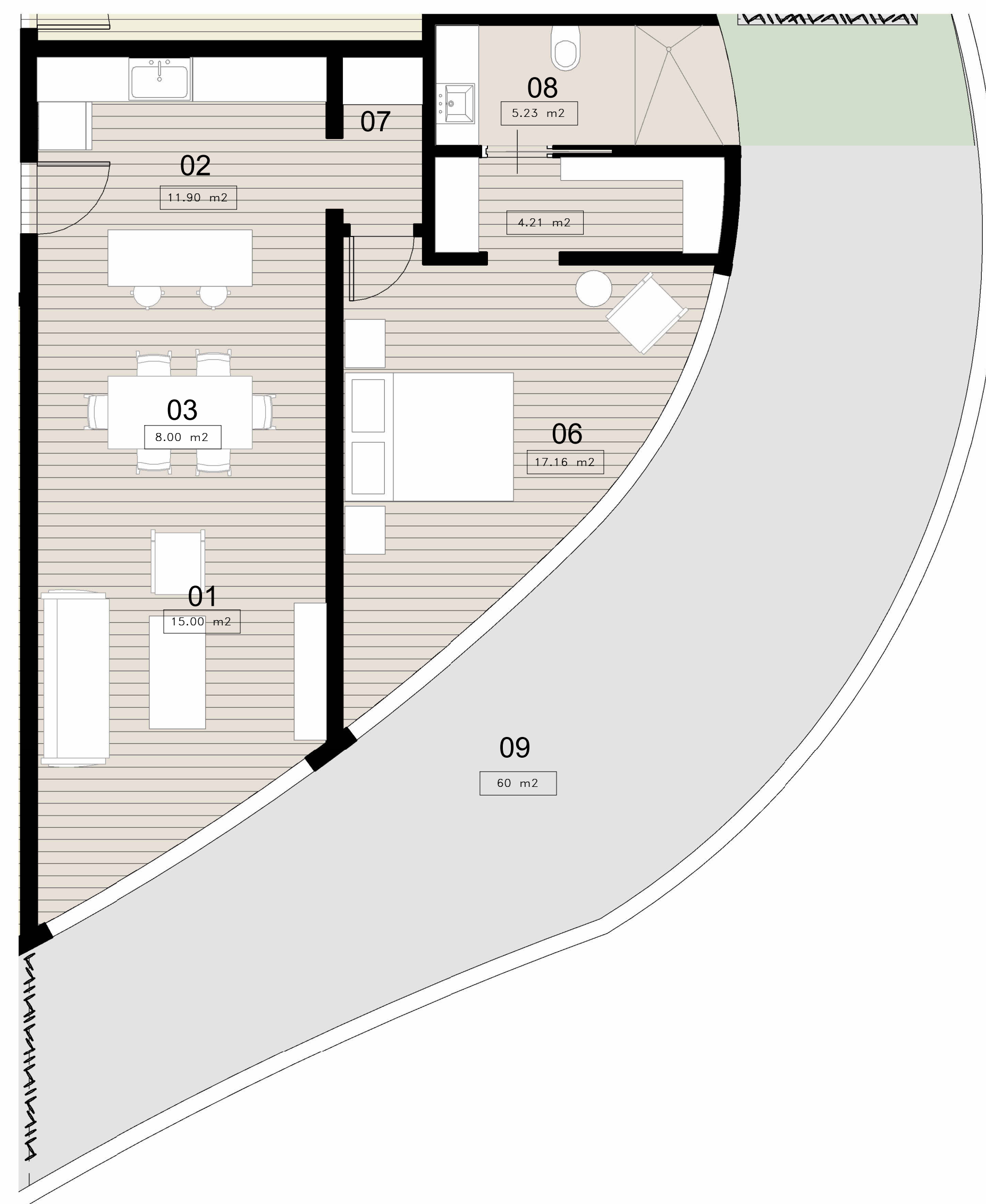

BLOQUE A
APARTAMENTO 306

UNA HABITACION

AREA INTERIOR TOTAL 67 m2

AREA TERRAZA 60 m2

AREA TOTAL 127 m2

SITEPLAN

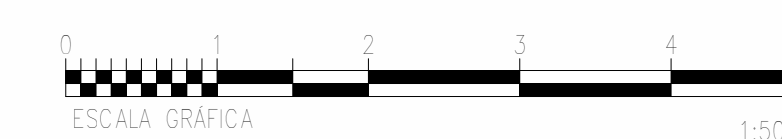
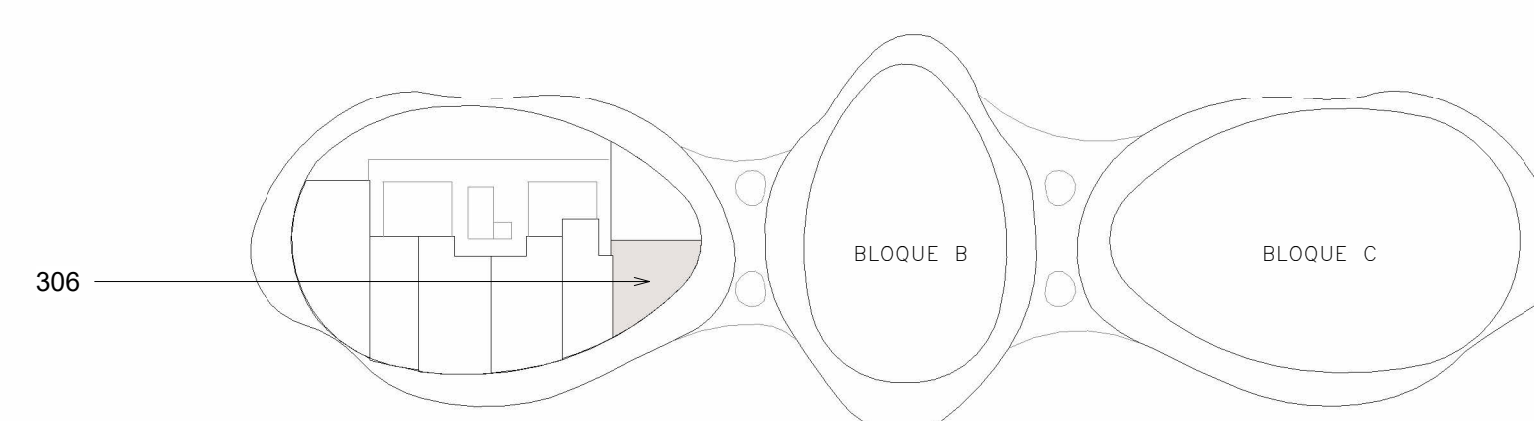

② BLOQUE A- apt 306
1 : 50

Norte del proyecto



Proyecto:



LE NID

Bayahibe, La Altagracia
Republica Dominicana

Propietario:

Leyenda

- 01 SALA
- 02 COCINA
- 03 COMEDOR
- 04 HABITACION SECUNDARIA
- 05 BAÑO 1
- 06 HABITACION PRINCIPAL
- 07 LAVADORA-SECADORA
- 08 BAÑO 2
- 09 TERRAZA

Equipo de trabajo

Diseño Arquitectonico:

Arq. Frederich Cedano

Codia:

Arq. Colaboradores:

Arq. Gabriela Moreno

Plano

Apartamento 307-BLOQUE A

A221

Escala

As indicated

Fecha:
AGOSTO
2024

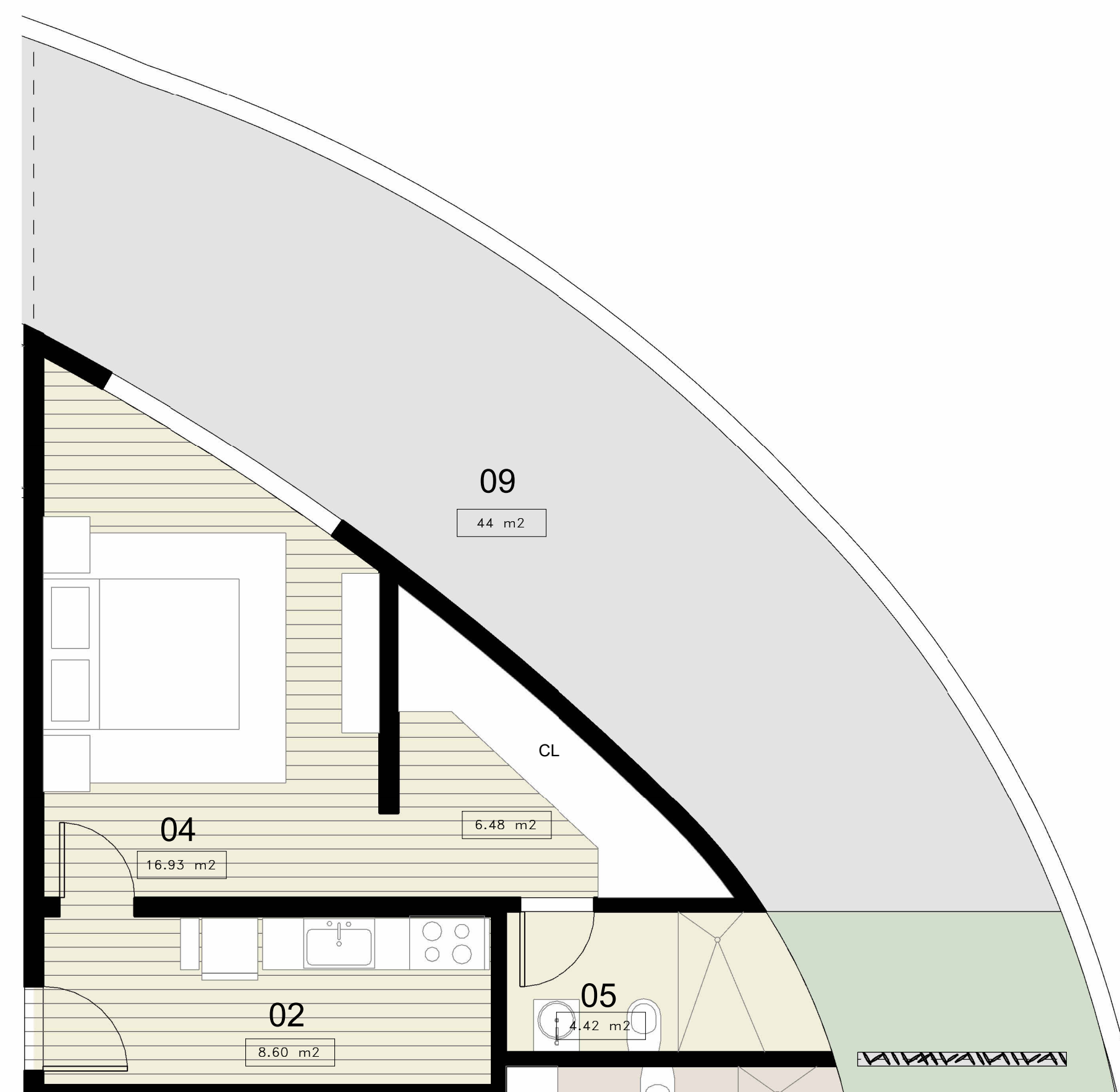

BLOQUE A
APARTAMENTO 307

UNA HABITACION

AREA INTERIOR TOTAL 39 m2

AREA TERRAZA 44 m2

AREA TOTAL 83 m2

SITEPLAN

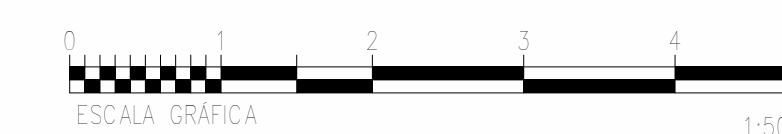
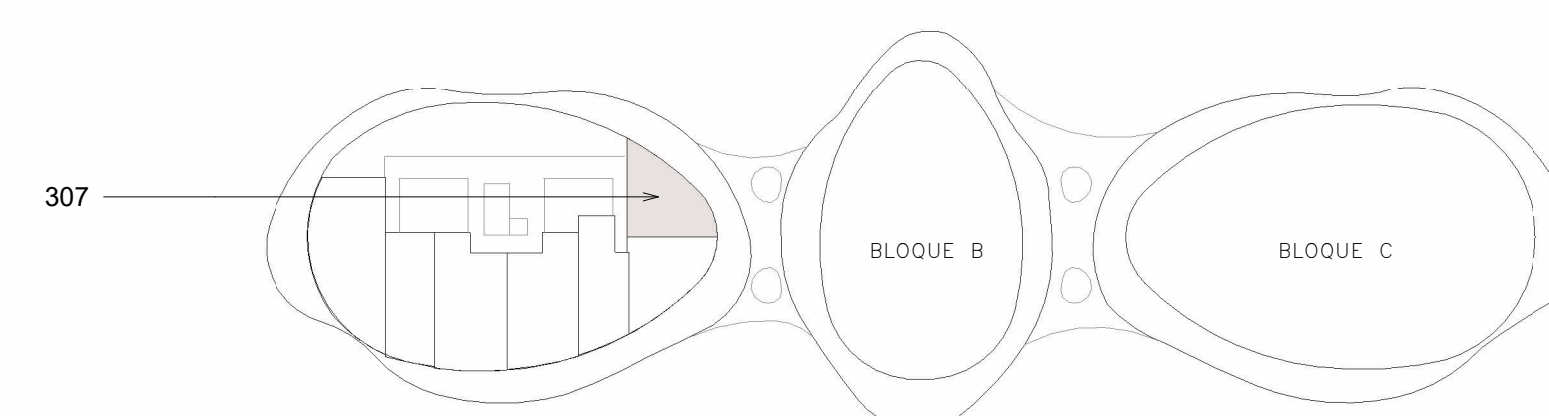

2 BLOQUE A- apt 307
1 : 50

Norte del proyecto



Proyecto:



LE NID

Bayahibe, La Altagracia
Republica Dominicana

Propietario:

Leyenda

- 01 SALA
- 02 COCINA
- 03 COMEDOR
- 04 HABITACION SECUNDARIA
- 05 BAÑO 1
- 06 HABITACION PRINCIPAL
- 07 LAVADORA-SECADORA
- 08 BAÑO 2
- 09 TERRAZA

Equipo de trabajo

Diseño Arquitectonico:

Arq. Frederich Cedano

Codia:

Arq. Colaboradores:

Arq. Gabriela Moreno

Plano

Apartamento 308-BLOQUE A

A222

Escala

As indicated

Fecha:
AGOSTO
2024

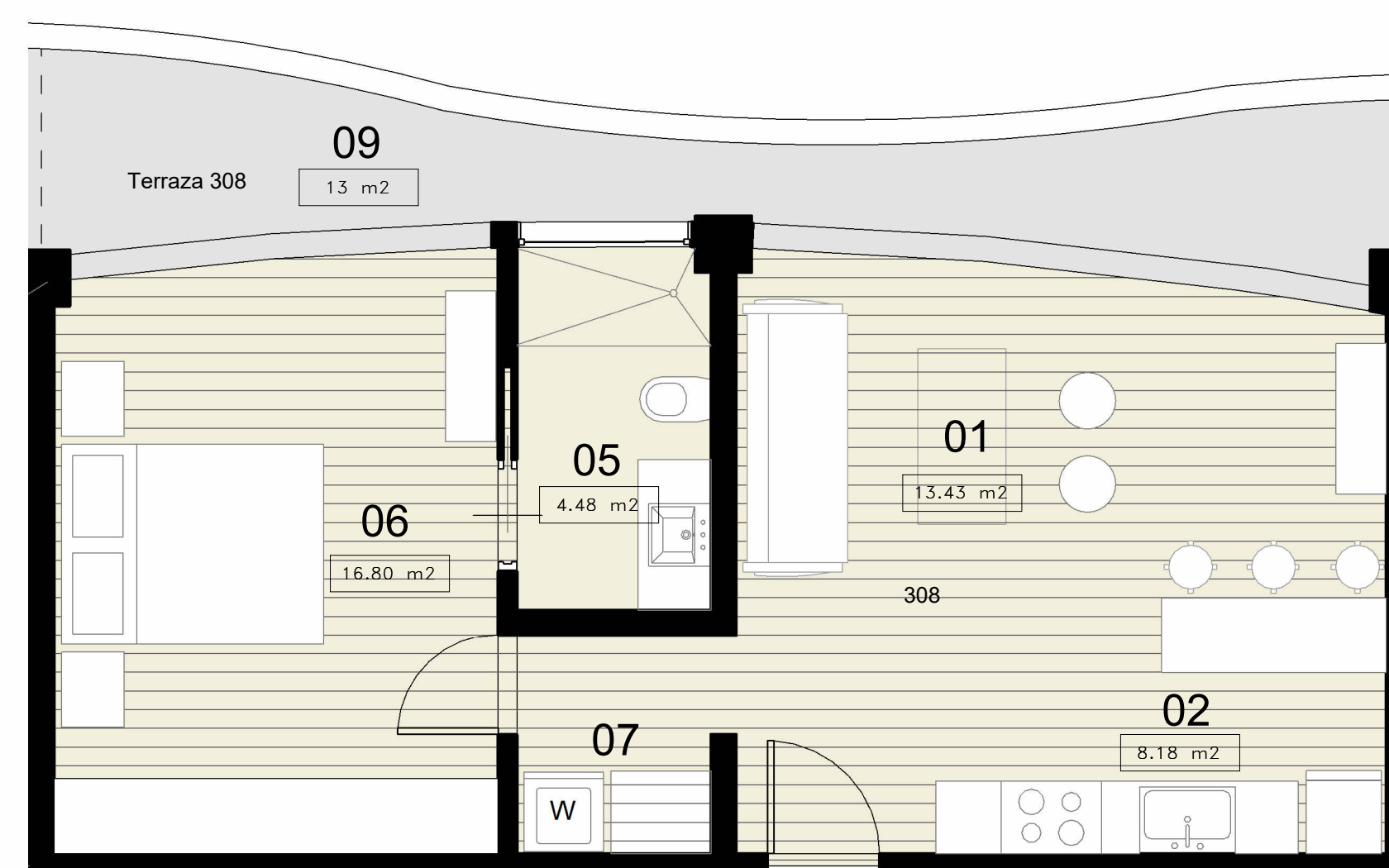

BLOQUE A
APARTAMENTO 308

UNA HABITACION

AREA INTERIOR TOTAL 50 m2

AREA TERRAZA 13 m2

AREA TOTAL 63 m2

SITEPLAN

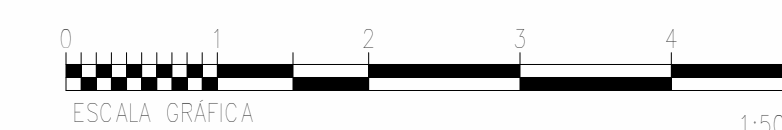
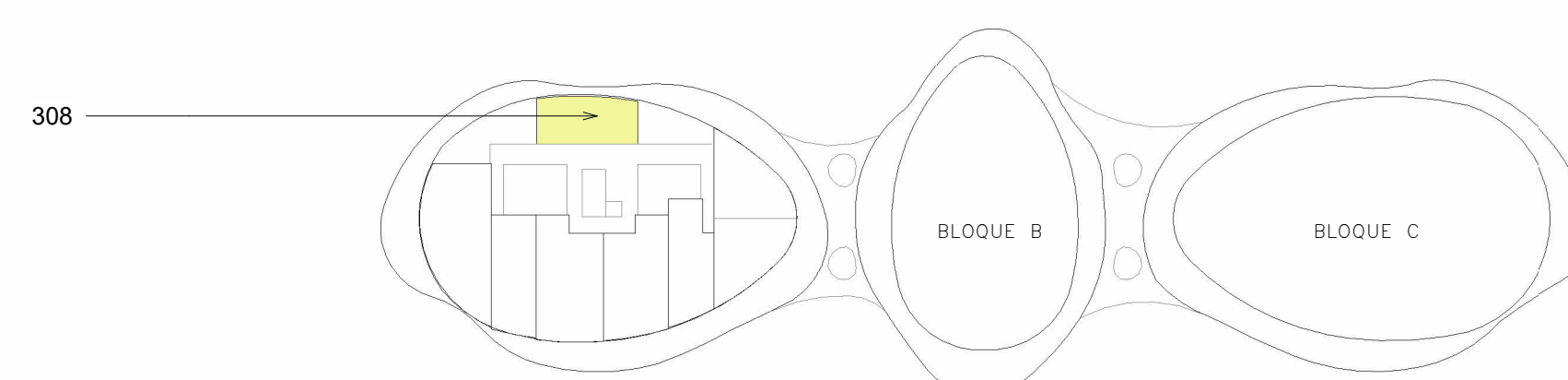

1 BLOQUE A- APT 308
1:50

Norte del proyecto



Proyecto:



LE NID

Bayahibe, La Altagracia
Republica Dominicana

Propietario:

Legenda

- 01 SALA
- 02 COCINA
- 03 COMEDOR
- 04 HABITACION SECUNDARIA
- 05 BAÑO 1
- 06 HABITACION PRINCIPAL
- 07 LAVADORA-SECADORA
- 08 BAÑO 2
- 09 TERRAZA
- 10 BAÑO 3
- 11 BAÑO 4

Equipo de trabajo

Diseño Arquitectonico:

Arq. Frederich Cedano

Codia:

Arq. Colaboradores:

Arq. Gabriela Moreno

Plano

Apartamento 401 - BLOQUE A

A223

Escala

As indicated

Fecha:

AGOSTO
2024

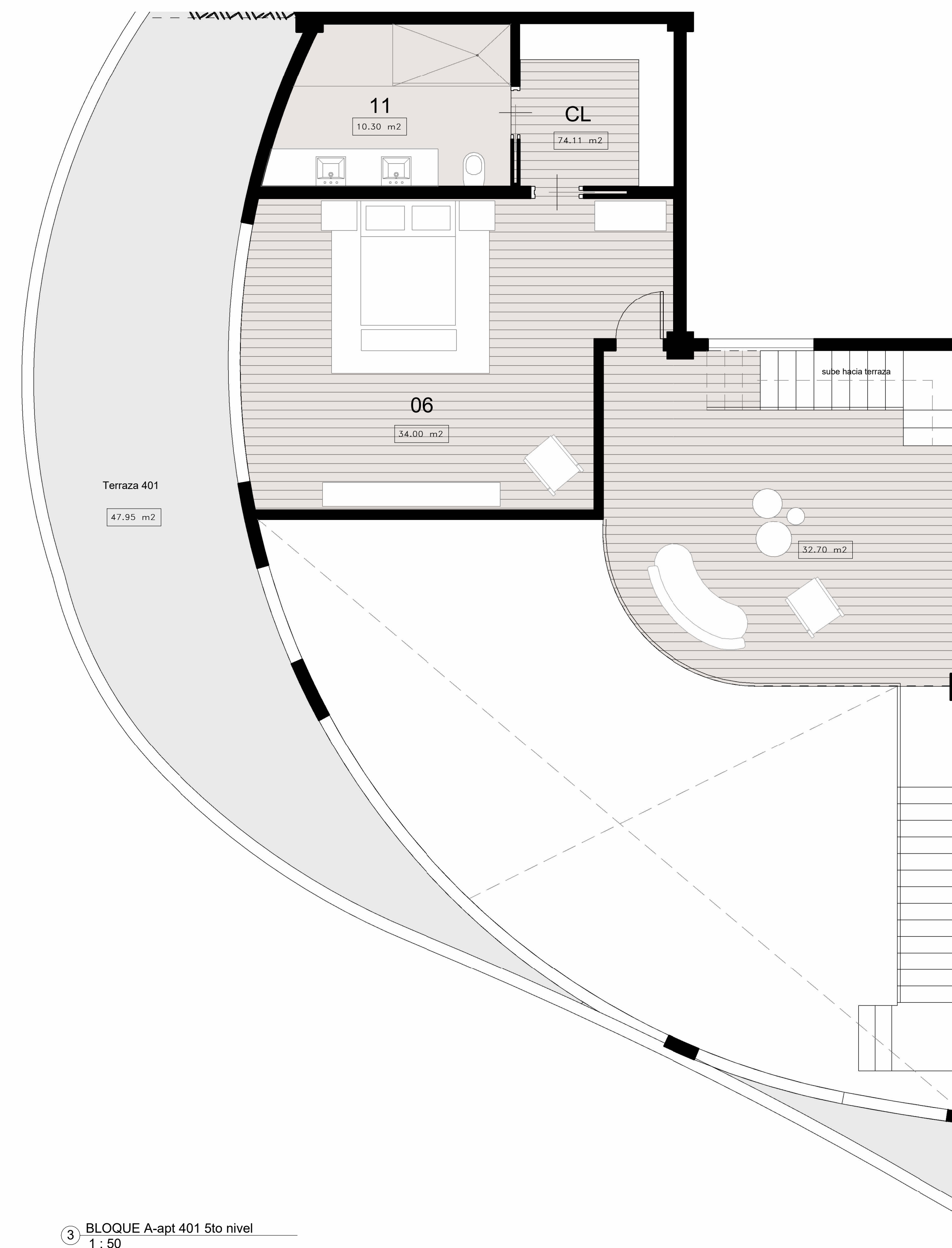

BLOQUE A
APARTAMENTO 401

CUATRO HABITACIONES

AREA INTERIOR TOTAL 244 m2

AREA TOTAL TERRAZA 302 m2

AREA TOTAL 546 m2

SITEPLAN

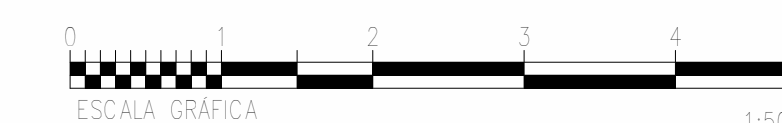
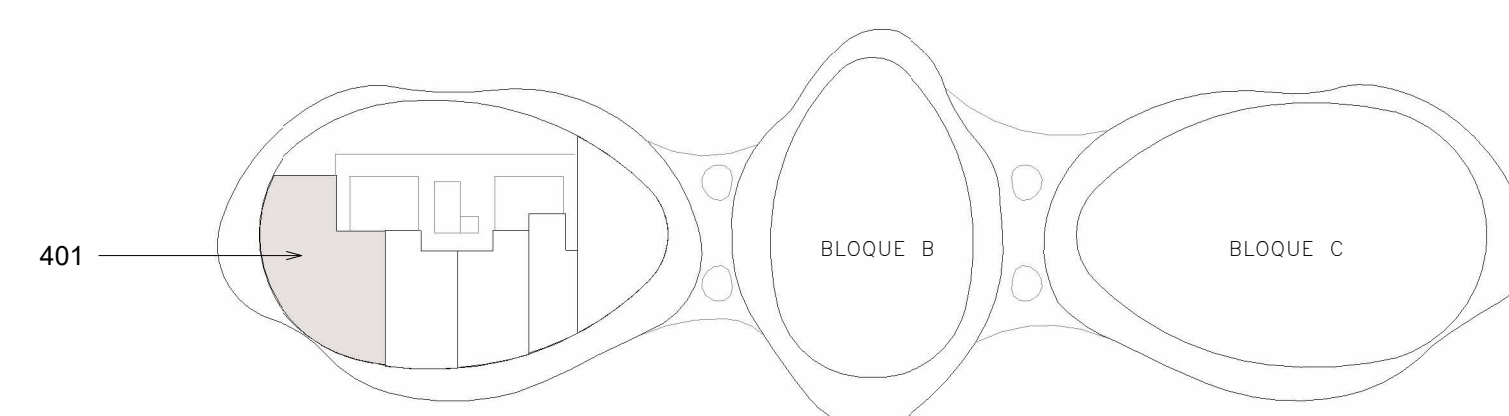

Norte del proyecto



Proyecto:

LE NID

Bayahibe, La Altagracia
Republica Dominicana

Propietario:

Leyenda

- 01 SALA
- 02 COCINA
- 03 COMEDOR
- 04 HABITACION SECUNDARIA
- 05 BAÑO 1
- 06 HABITACION PRINCIPAL
- 07 LAVADORA-SECADORA
- 08 BAÑO 2
- 09 TERRAZA
- 10 BAÑO 3
- 11 BAÑO 4

Equipo de trabajo

Diseño Arquitectonico:

Arq. Frederich Cedano

Codia:

Arq. Colaboradores:

Arq. Gabriela Moreno

Plano

**Apartamento 401 - BLOQUE A
terraza**

A224

Escala

As indicated

Fecha:

AGOSTO
2024

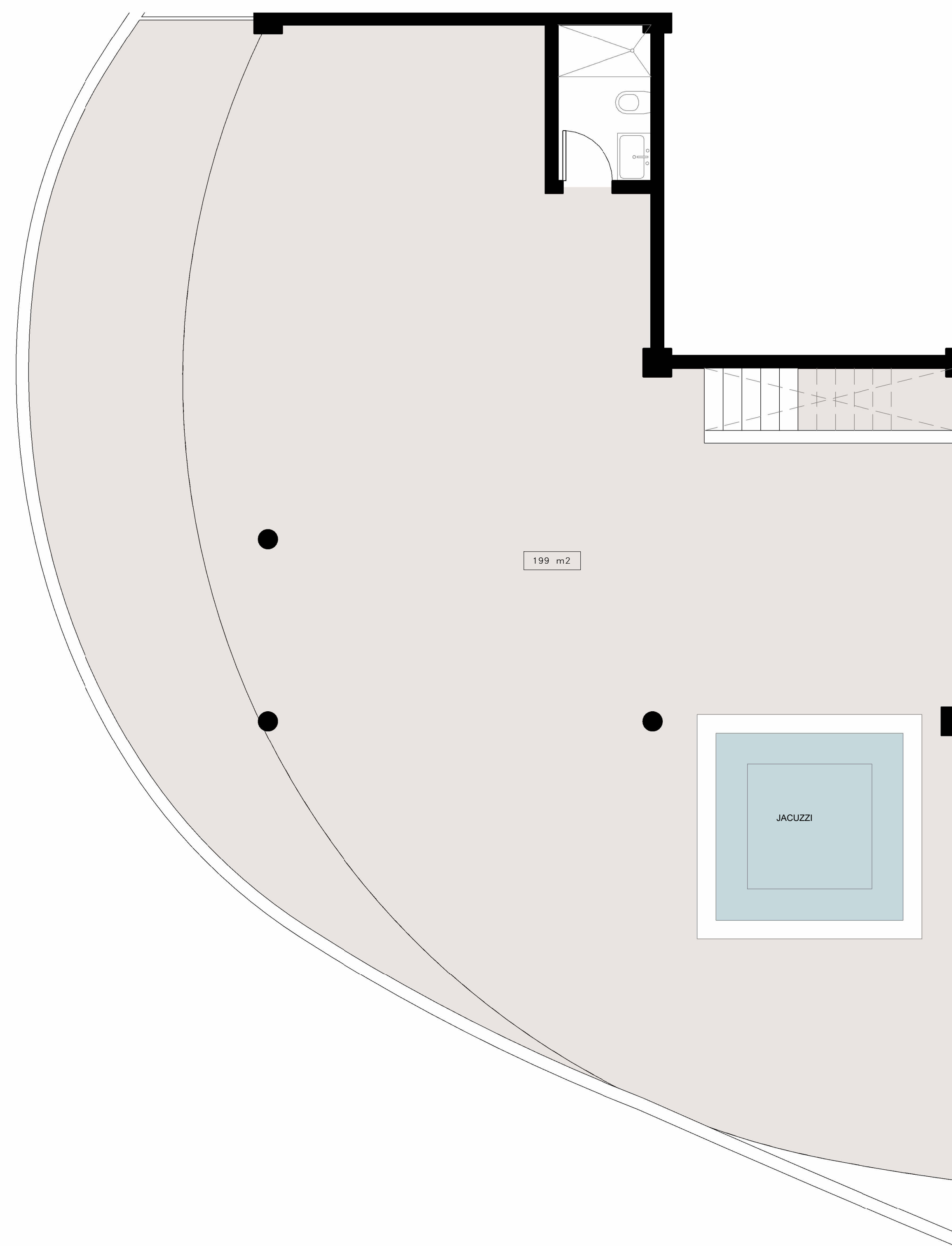

**BLOQUE A
APARTAMENTO 401**

CUATRO HABITACIONES

AREA INTERIOR TOTAL 244 m2

AREA TOTAL TERRAZA 302 m2

AREA TOTAL 546 m2

SITEPLAN

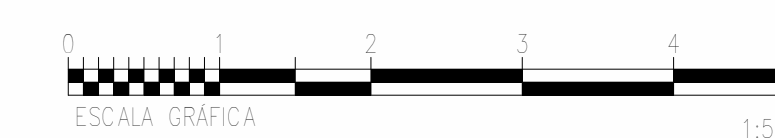
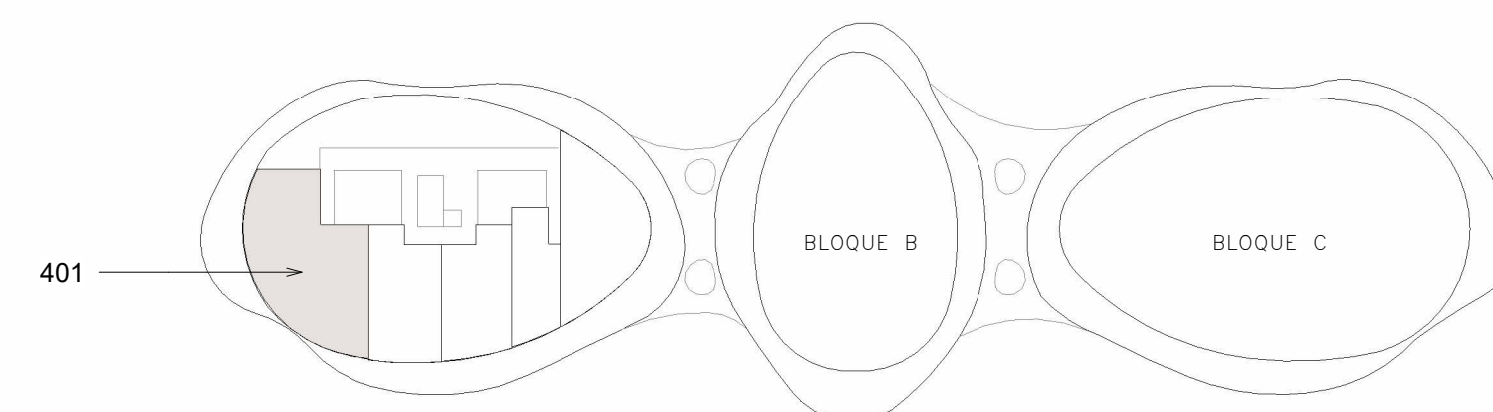

1 Bloque A- apt 401 terraza
1 : 50

Norte del proyecto



Proyecto:



LE NID

Bayahibe, La Altagracia
Republica Dominicana

Propietario:

Leyenda

- 01 SALA
- 02 COCINA
- 03 COMEDOR
- 04 HABITACION SECUNDARIA
- 05 BAÑO 1
- 06 HABITACION PRINCIPAL
- 07 LAVADORA-SECADORA
- 08 BAÑO 2
- 09 TERRAZA
- 10 BAÑO 3

Equipo de trabajo

Diseño Arquitectonico:
Arq. Frederich Cedano
Codia:
Arq. Colaboradores:
Arq. Gabriela Moreno

Plano

Apartamento 402 - BLOQUE A

A225

Escala

As indicated

Fecha:
AGOSTO
2024

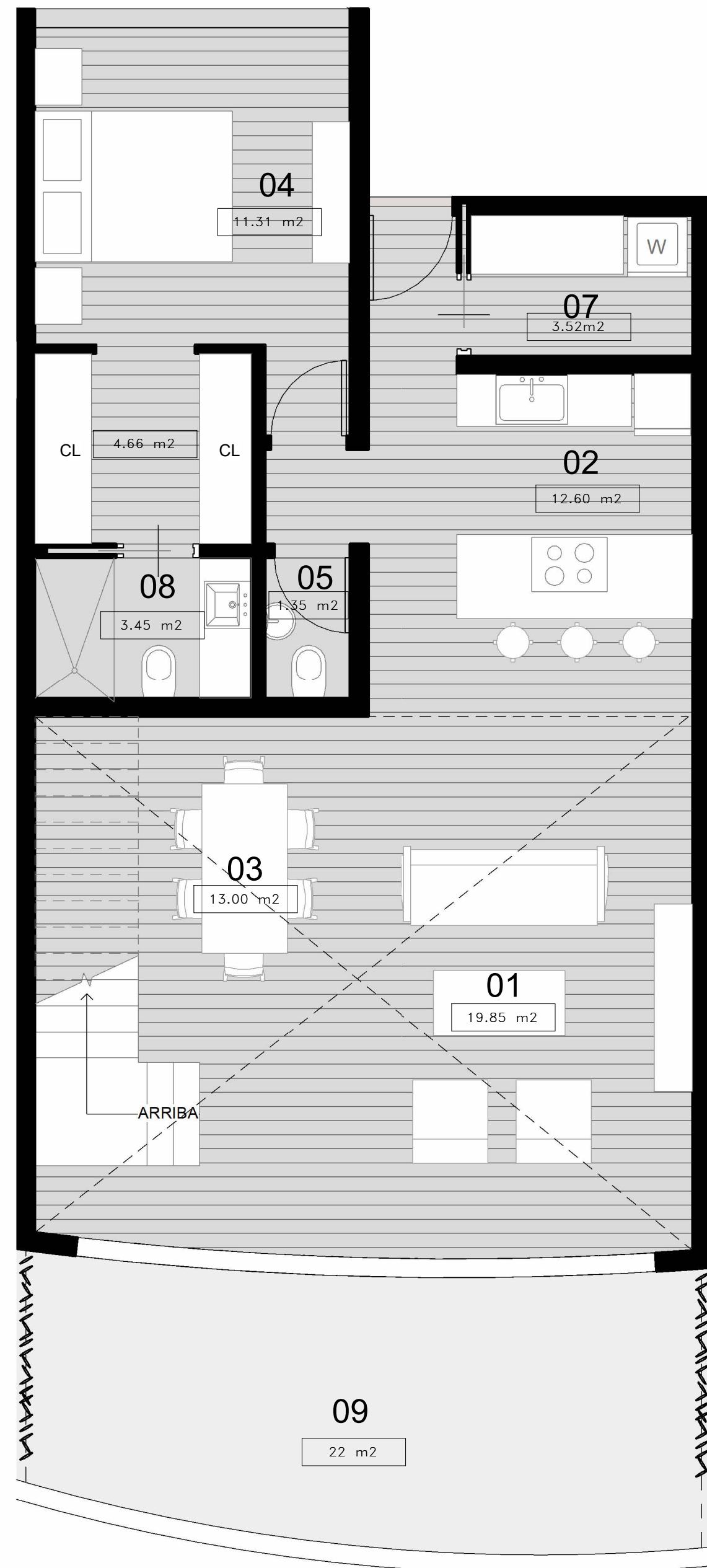

① Bloque A- apt 402 4to nivel
1 : 50

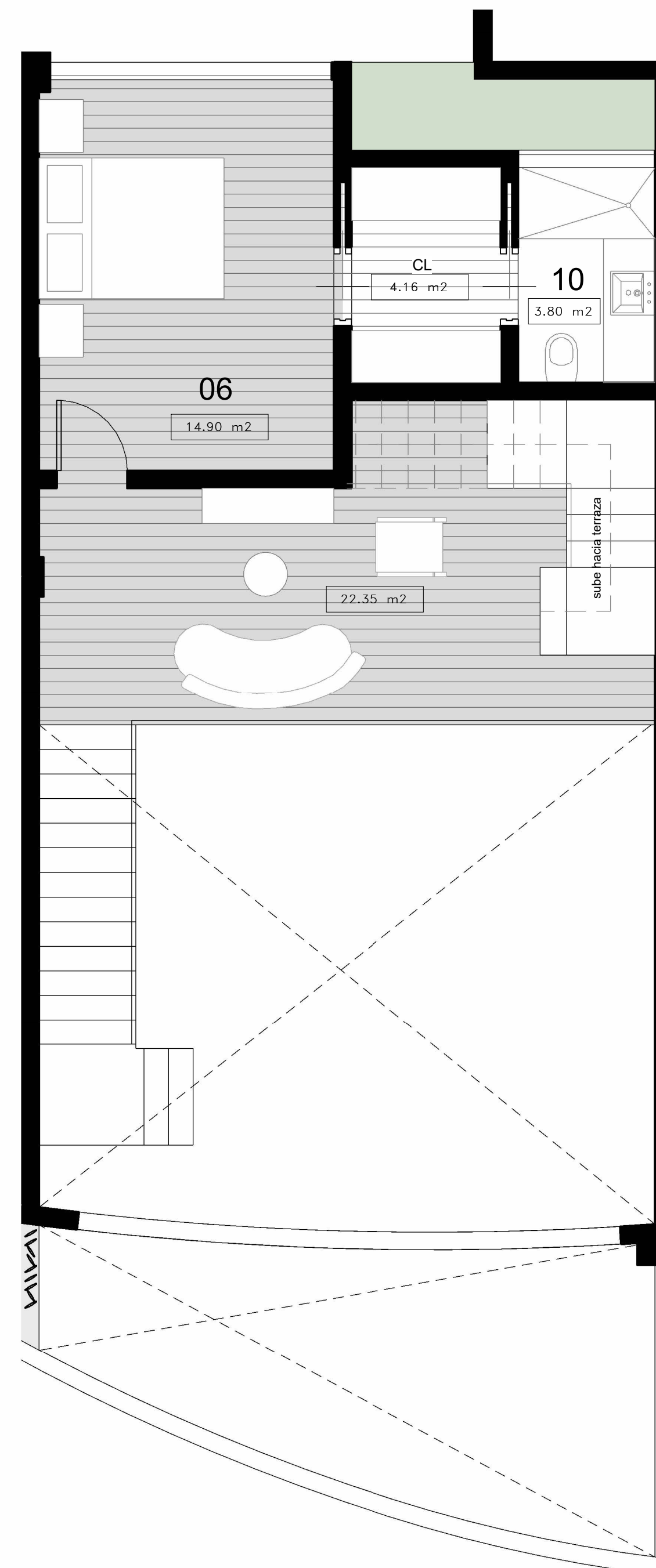

② Bloque A- Apt 402 5to nivel
1 : 50

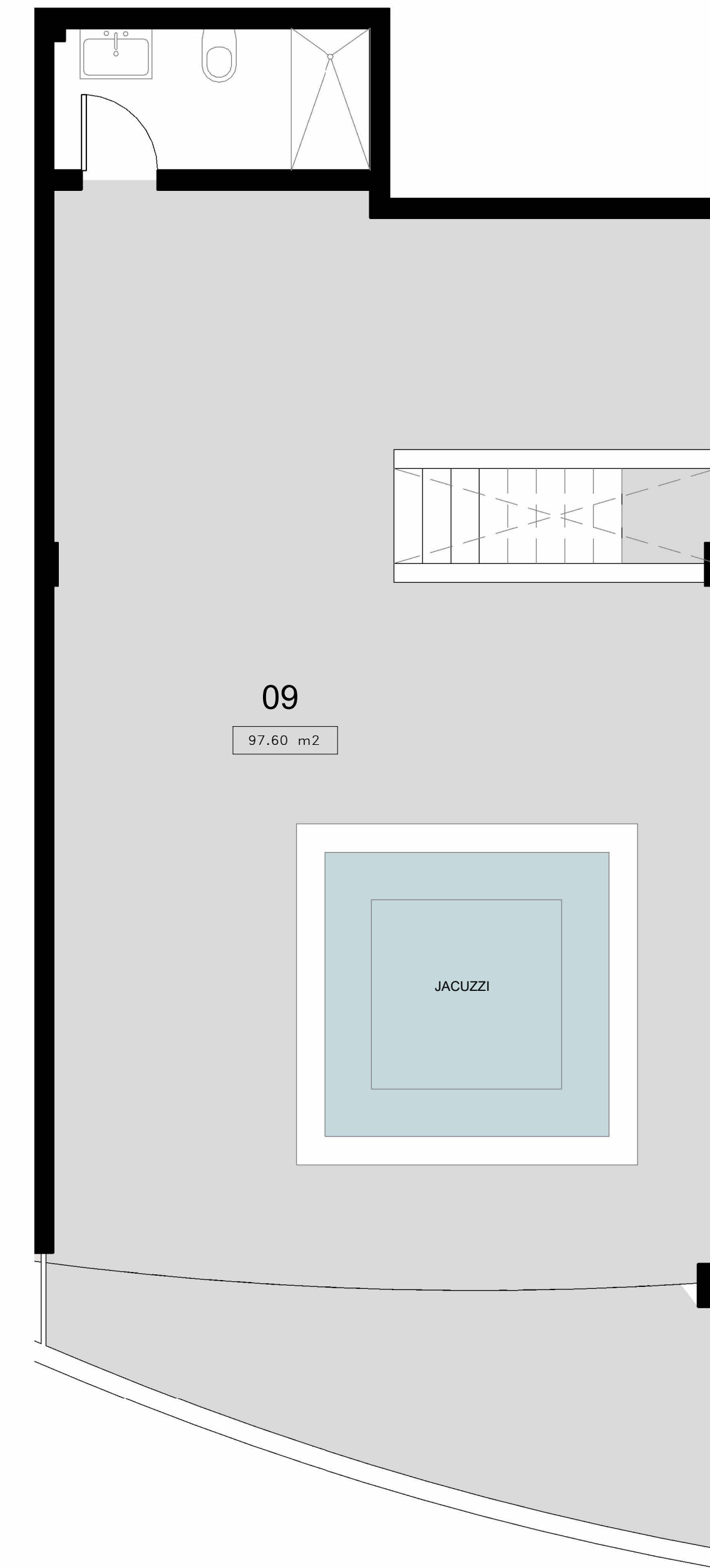

③ BLOQUE A- apt 402 terraza
1 : 50

BLOQUE A
APARTAMENTO 402
DOS HABITACIONES

AREA INTERIOR TOTAL 121 m2
AREA TOTAL TERRAZA 121 m2
AREA TOTAL 242 m2

SITEPLAN

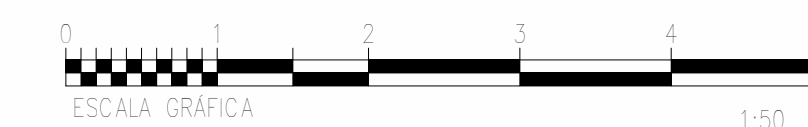
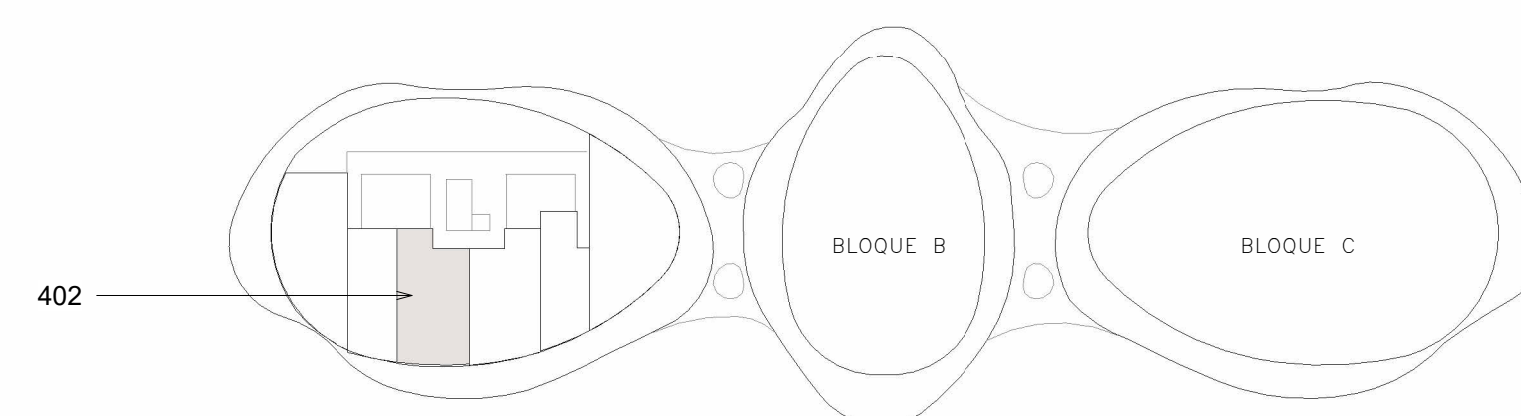

Norte del proyecto



Proyecto:



LE NID

Bayahibe, La Altagracia
Republica Dominicana

Propietario:

Leyenda

- 01 SALA
- 02 COCINA
- 03 COMEDOR
- 04 HABITACION SECUNDARIA
- 05 BAÑO 1
- 06 HABITACION PRINCIPAL
- 07 LAVADORA-SECADORA
- 08 BAÑO 2
- 09 TERRAZA
- 10 BAÑO 3

Equipo de trabajo

Diseño Arquitectonico:
Arq. Frederich Cedano
Codia:
Arq. Colaboradores:
Arq. Gabriela Moreno

Plano

Apartamento 403 - BLOQUE A

A226

Escala

As indicated

Fecha:
AGOSTO
2024

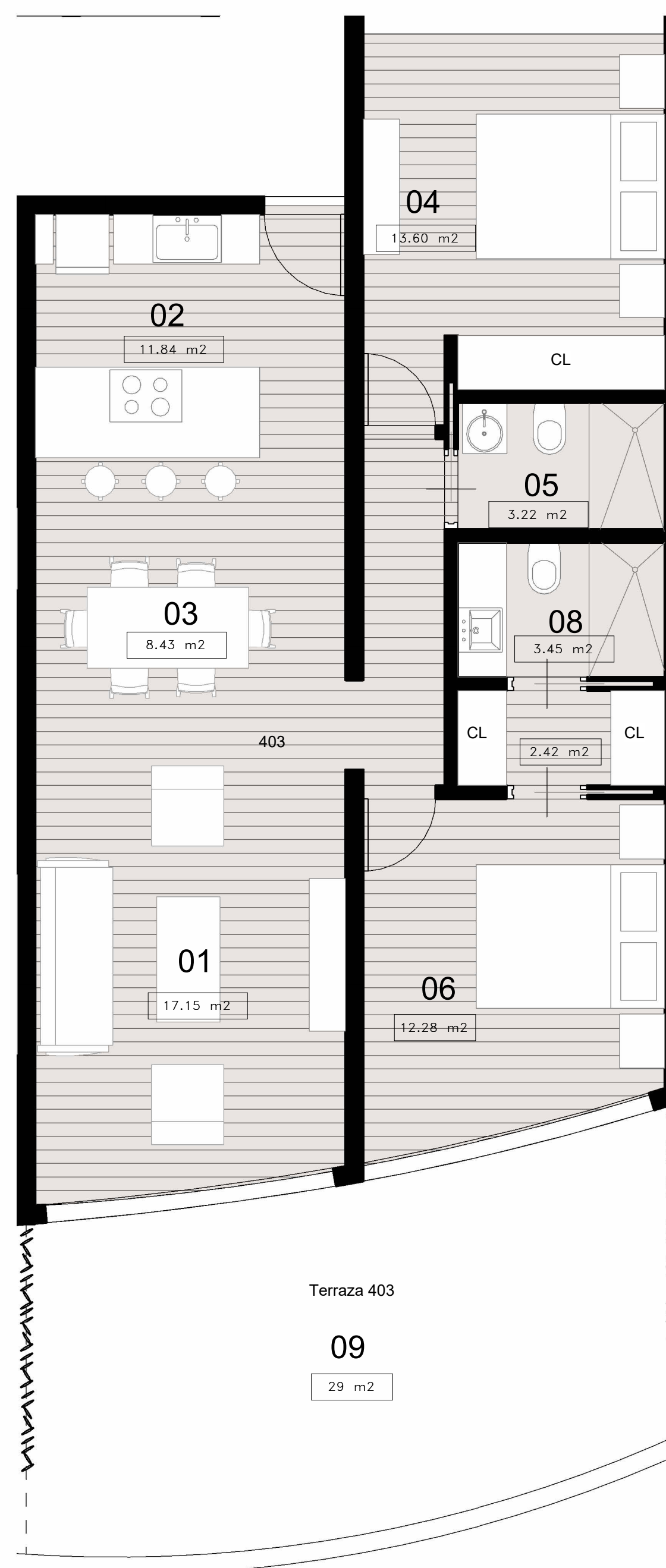

BLOQUE A
APARTAMENTO 403
DOS HABITACIONES

AREA INTERIOR TOTAL 81 m2
AREA TERRAZA 29 m2
AREA TOTAL 110 m2

SITEPLAN

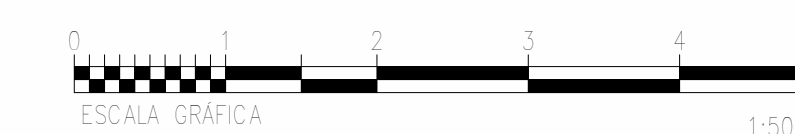
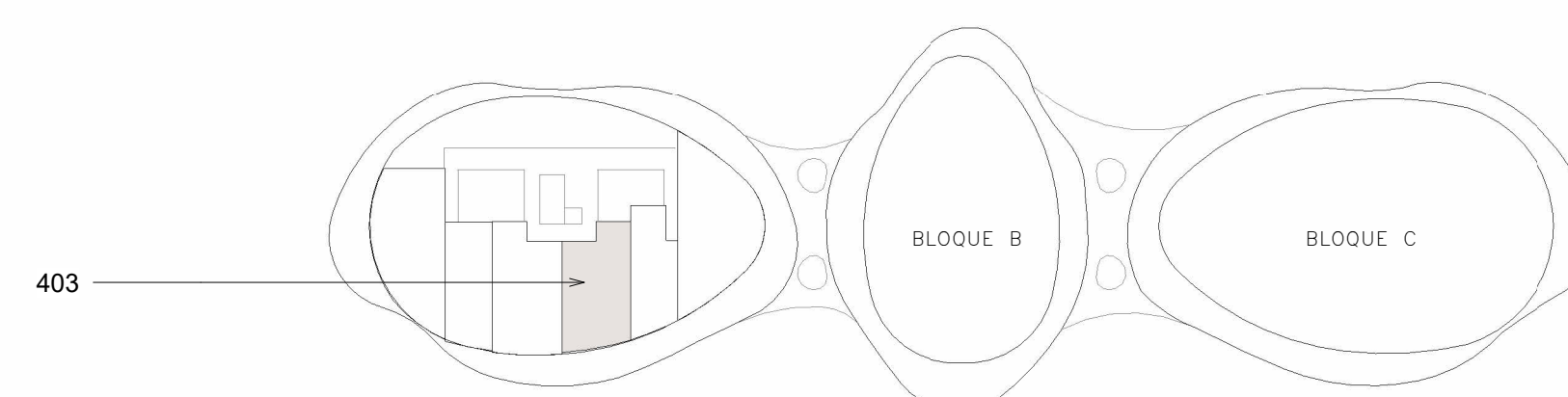

1 BLOQUE A - apt 403
1:50

Norte del proyecto



Proyecto:



LE NID

Bayahibe, La Altagracia
Republica Dominicana

Propietario:

Leyenda

- 01 SALA
- 02 COCINA
- 03 COMEDOR
- 04 HABITACION SECUNDARIA
- 05 BAÑO 1
- 06 HABITACION PRINCIPAL
- 07 LAVADORA-SECADORA
- 08 BAÑO 2
- 09 TERRAZA
- 10 BAÑO 3

Equipo de trabajo

Diseño Arquitectonico:
Arq. Frederich Cedano
Codia:
Arq. Colaboradores:
Arq. Gabriela Moreno

Plano

Apartamento 404 - BLOQUE A

A227

Escala

As indicated

Fecha:
AGOSTO
2024

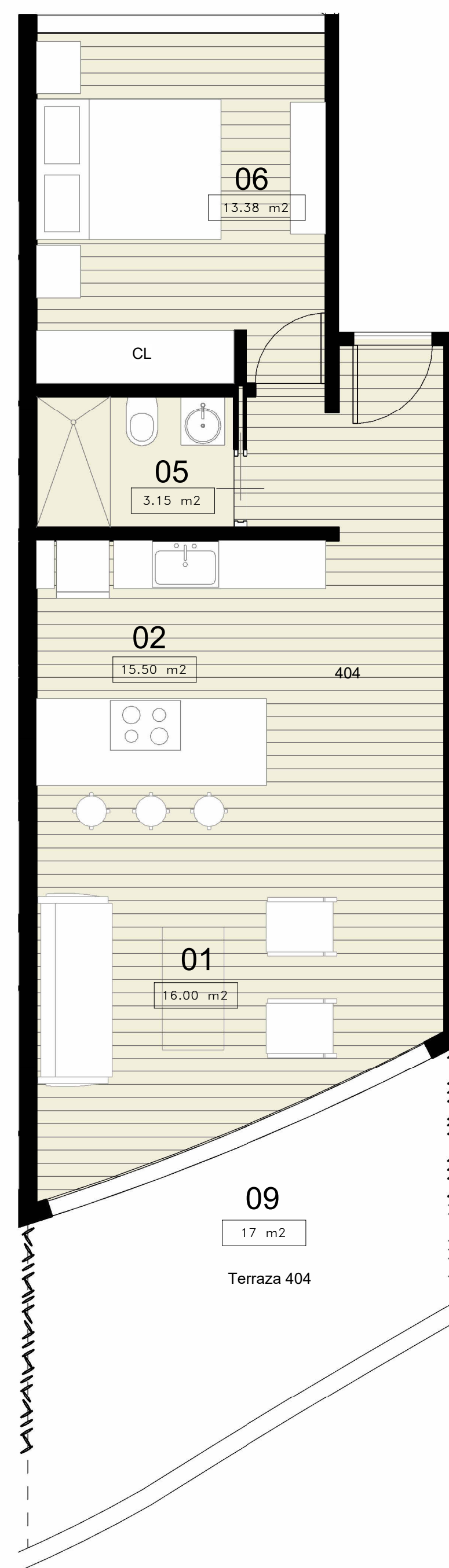

BLOQUE A
APARTAMENTO 404

UNA HABITACION

AREA INTERIOR TOTAL 53 m2

AREA TERRAZA 17 m2

AREA TOTAL 70 m2

SITEPLAN

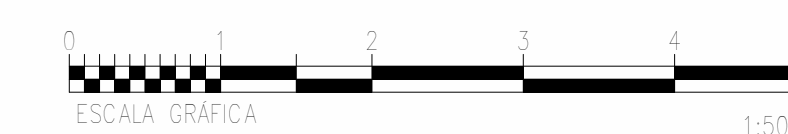
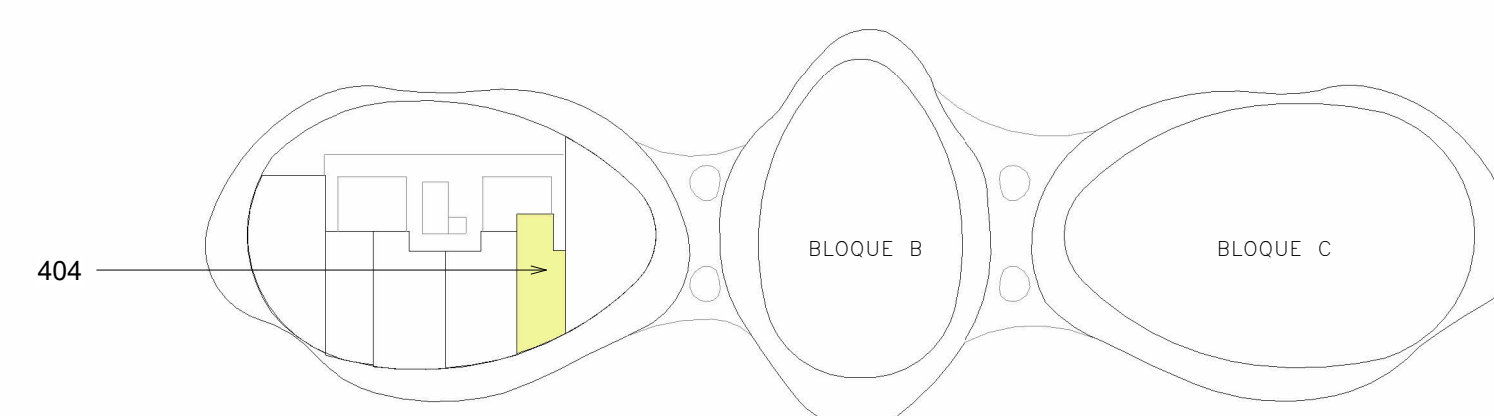

① BLOQUE A - apt 404
1 : 50

Norte del proyecto



Proyecto:



LE NID

Bayahibe, La Altagracia
Republica Dominicana

Propietario:

Leyenda

- 01 SALA
- 02 COCINA
- 03 COMEDOR
- 04 HABITACION SECUNDARIA
- 05 BAÑO 1
- 06 HABITACION PRINCIPAL
- 07 LAVADORA-SECADORA
- 08 BAÑO 2
- 09 TERRAZA
- 10 BAÑO 3

Equipo de trabajo

Diseño Arquitectonico:
Arq. Frederich Cedano
Codia:

Arq. Colaboradores:

Arq. Gabriela Moreno

Plano

Apartamento 405 - BLOQUE A

A228

Escala

As indicated

Fecha:
AGOSTO
2024

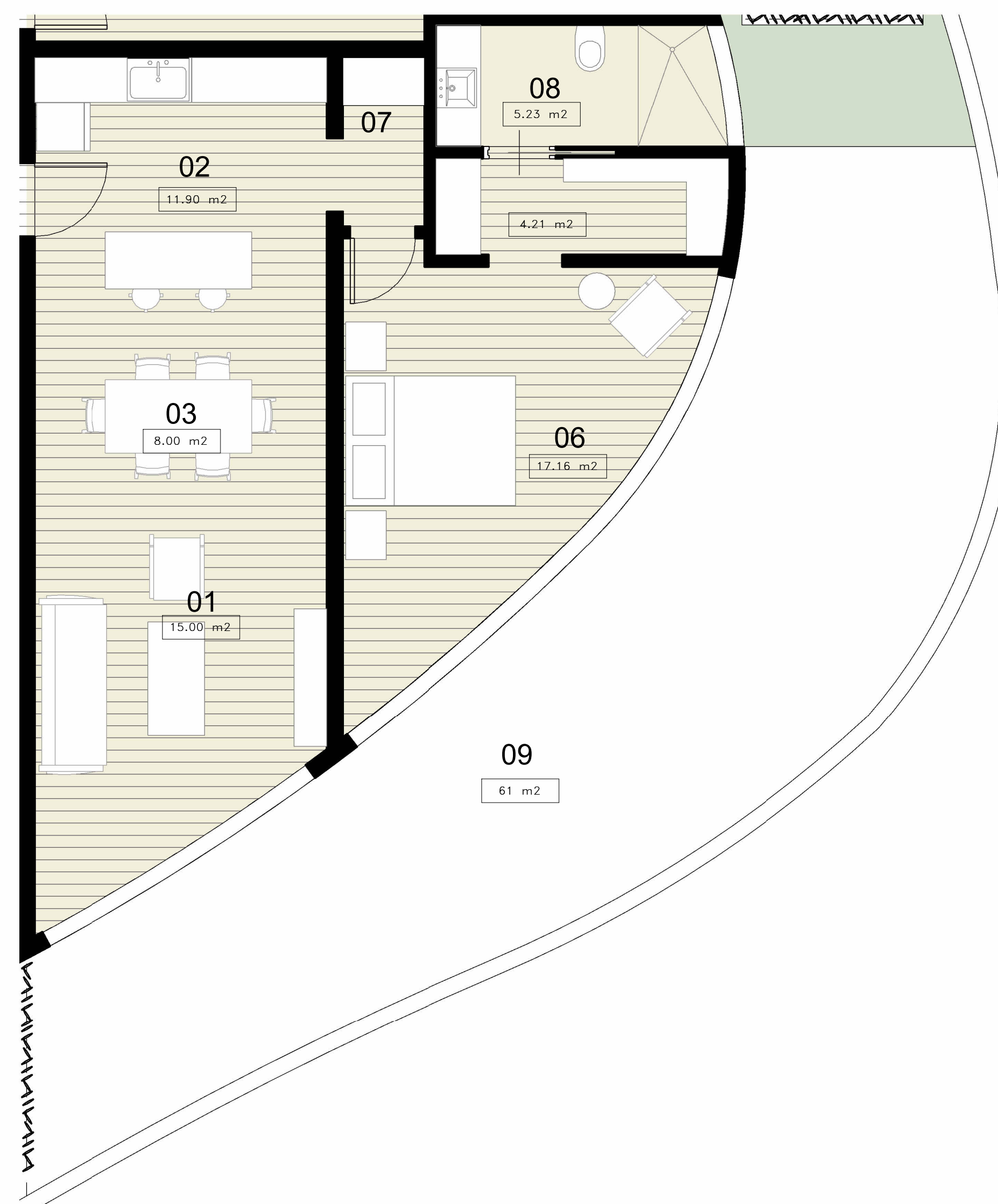

BLOQUE A
APARTAMENTO 405

UNA HABITACION

AREA INTERIOR TOTAL 66 m2

AREA TERRAZA 61 m2

AREA TOTAL 127 m2

SITEPLAN

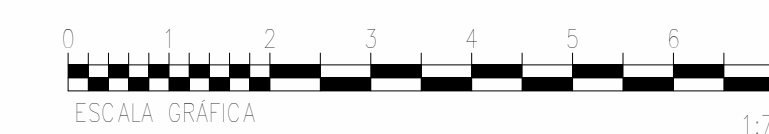
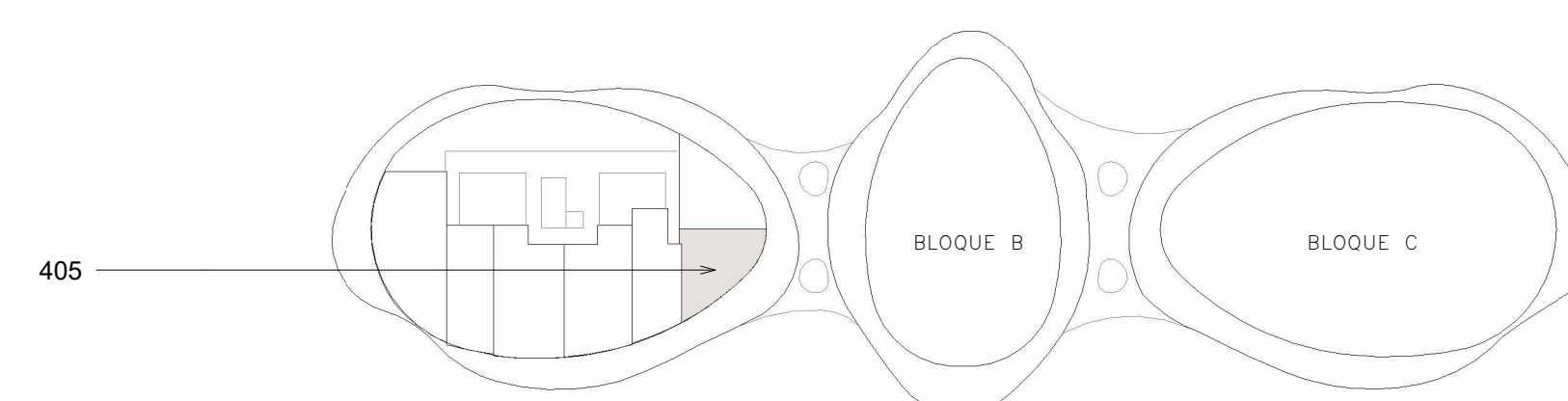

1 BLOQUE A - apt 405
1 : 50

Norte del proyecto



Proyecto:



LE NID

Bayahibe, La Altagracia
Republica Dominicana

Propietario:

Leyenda

- 01 SALA
- 02 COCINA
- 03 COMEDOR
- 04 HABITACION SECUNDARIA
- 05 BAÑO 1
- 06 HABITACION PRINCIPAL
- 07 LAVADORA-SECADORA
- 08 BAÑO 2
- 09 TERRAZA
- 10 BAÑO 3

Equipo de trabajo

Diseño Arquitectonico:

Arq. Frederich Cedano

Codia:

Arq. Colaboradores:

Arq. Gabriela Moreno

Plano

Apartamento 406 - BLOQUE A

A229

Escala

As indicated

Fecha:
AGOSTO
2024

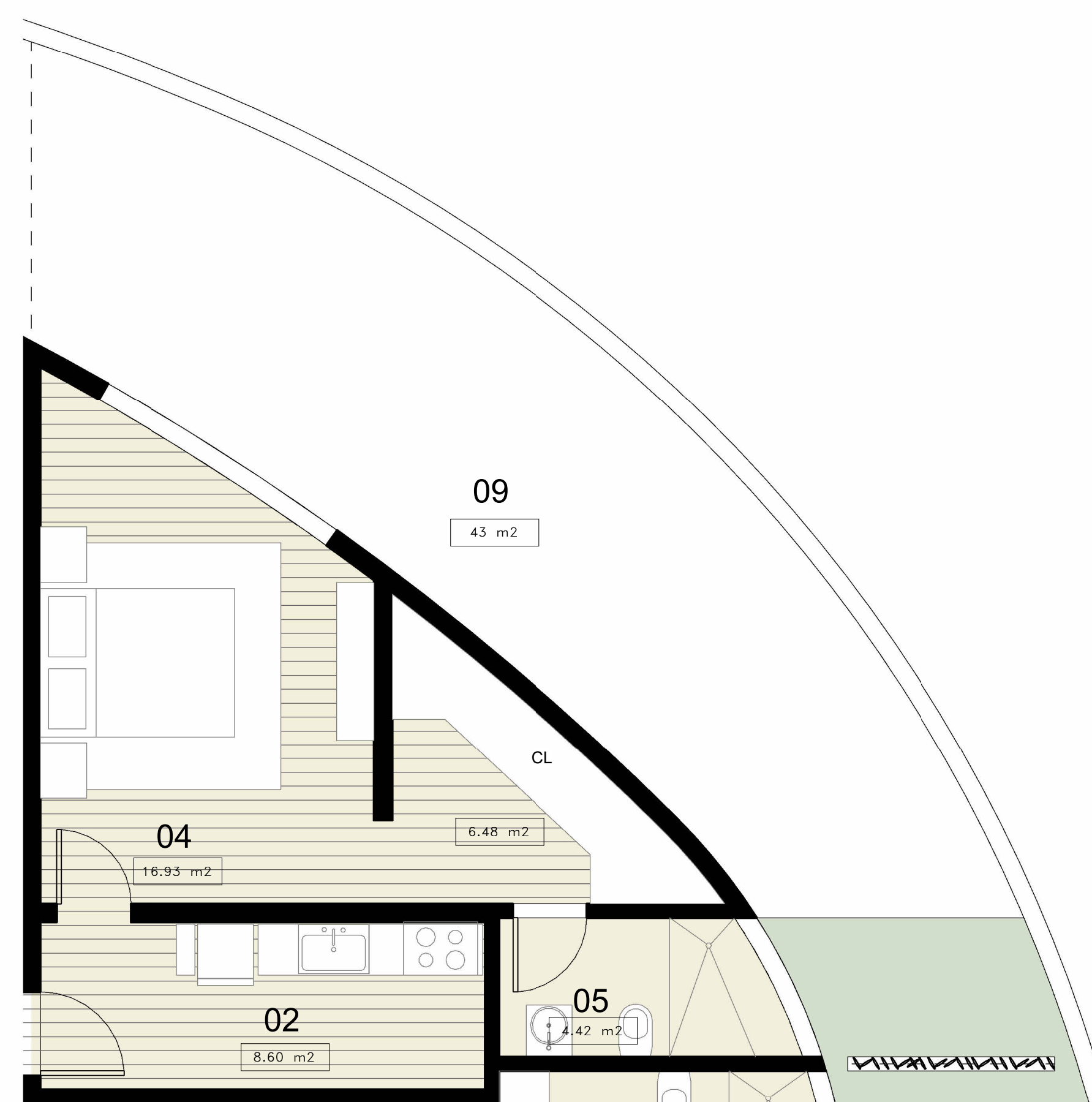

BLOQUE A
APARTAMENTO 406

UNA HABITACION

AREA INTERIOR TOTAL 39 m2

AREA TERRAZA 43 m2

AREA TOTAL 82 m2

SITEPLAN

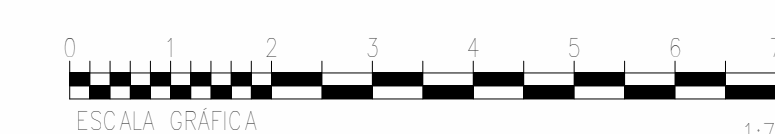
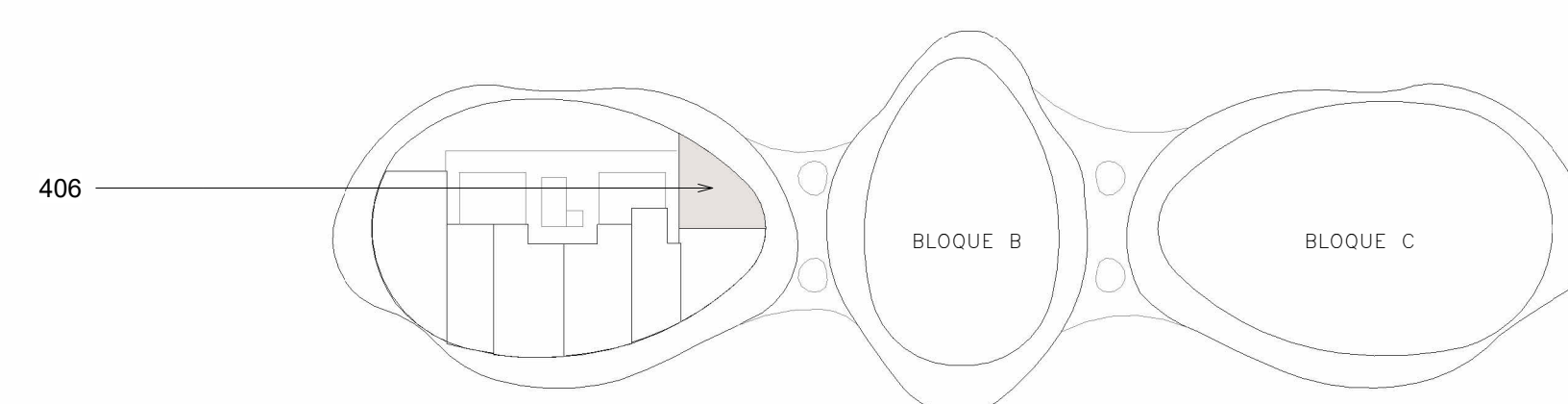

② BLOQUE A - apt 406
1 : 50

Norte del proyecto



Proyecto:



LE NID

Bayahibe, La Altagracia
Republica Dominicana

Propietario:

Leyenda

- 01 SALA
- 02 COCINA
- 03 COMEDOR
- 04 HABITACION SECUNDARIA
- 05 BAÑO 1
- 06 HABITACION PRINCIPAL
- 07 LAVADORA-SECADORA
- 08 BAÑO 2
- 09 TERRAZA
- 10 BAÑO 3

Equipo de trabajo

Diseño Arquitectonico:
Arq. Frederich Cedano
Codia:
Arq. Colaboradores:
Arq. Gabriela Moreno

Plano

Apartamento 407 - BLOQUE A

A230

Escala

As indicated

Fecha:
AGOSTO
2024

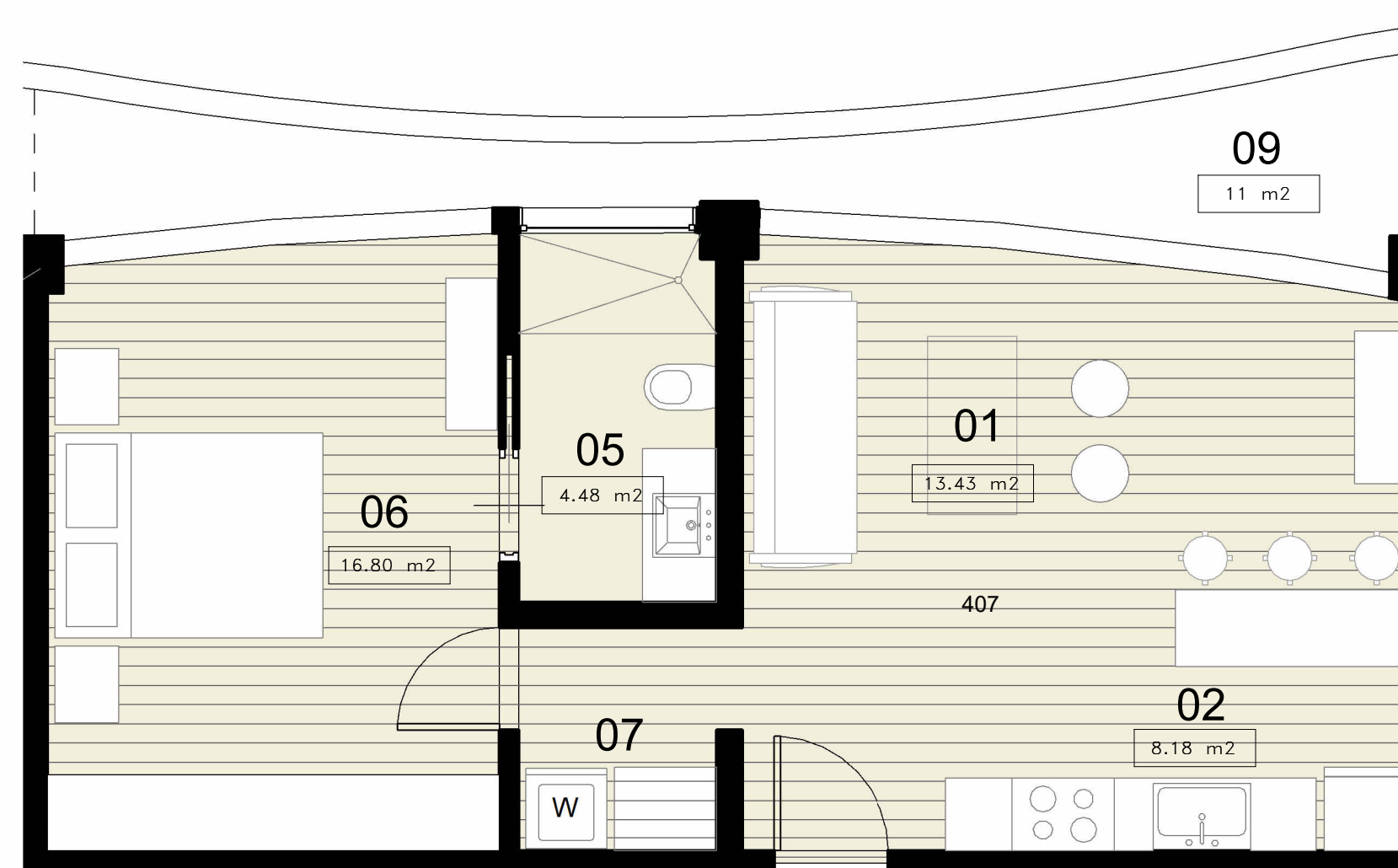

BLOQUE A
APARTAMENTO 407

UNA HABITACION

AREA INTERIOR TOTAL 50 m2
AREA TERRAZA 11 m2
AREA TOTAL 61 m2

SITEPLAN

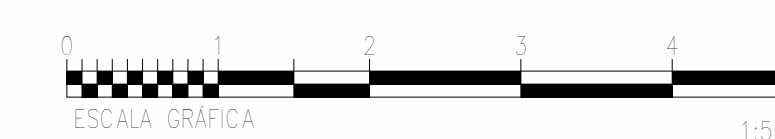
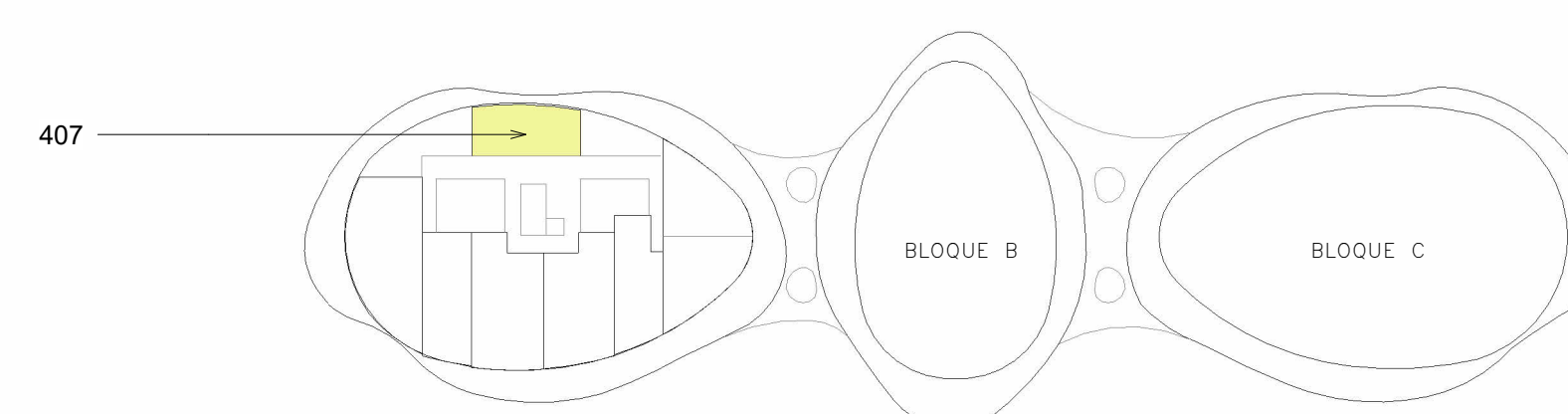

① BLOQUE A - apt 407
1:50

Norte del proyecto



Proyecto:



LE NID

Bayahibe, La Altagracia
Republica Dominicana

Propietario:

Legenda

- 01 SALA
- 02 COCINA
- 03 COMEDOR
- 04 HABITACION SECUNDARIA
- 05 BAÑO 1
- 06 HABITACION PRINCIPAL
- 07 LAVADORA-SECADORA
- 08 BAÑO 2
- 09 TERRAZA
- 10 BAÑO 3

Equipo de trabajo

Diseño Arquitectonico:

Arq. Frederich Cedano

Codia:

Arq. Colaboradores:

Arq. Gabriela Moreno

Plano

Apartamento 503 - BLOQUE A

A231

Escala

As indicated

Fecha:

AGOSTO
2024

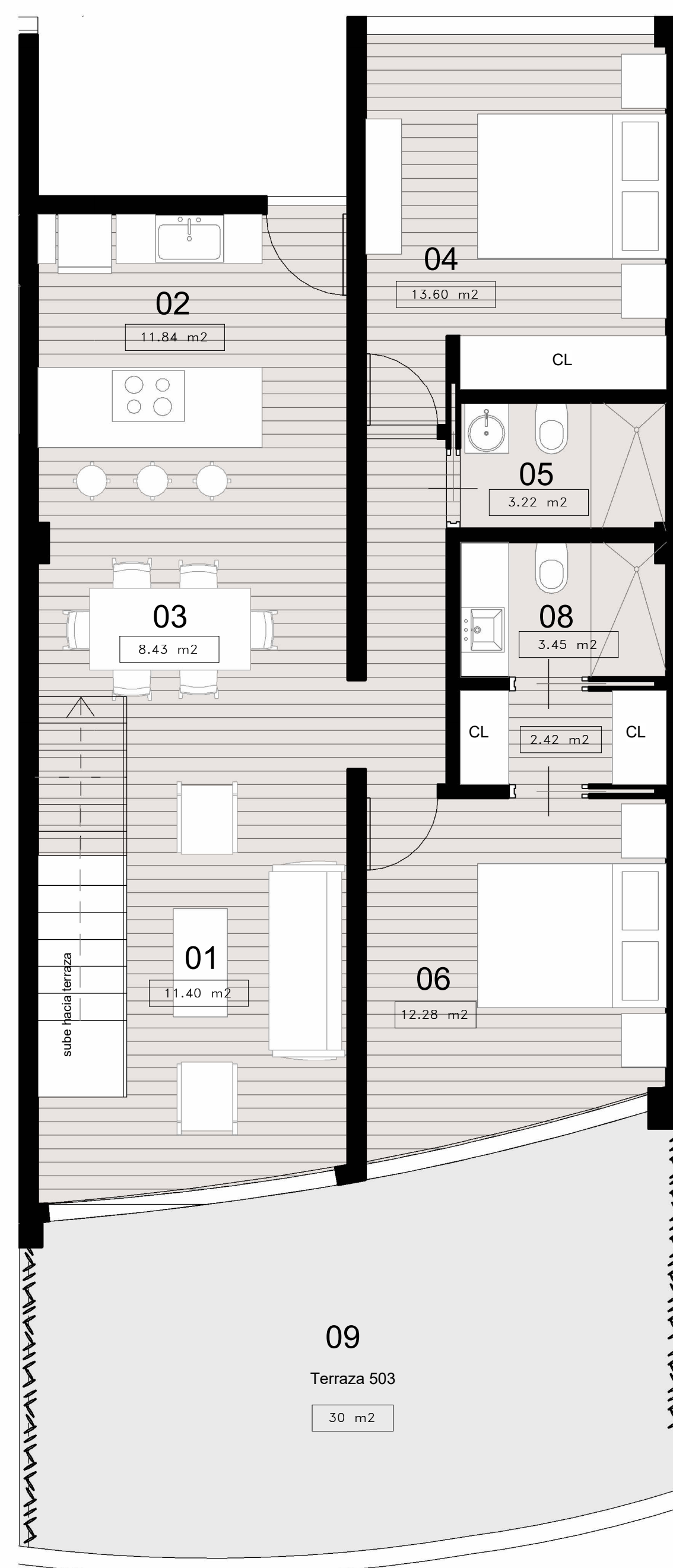

① Bloque A - apt 503 5to nivel
1 : 50

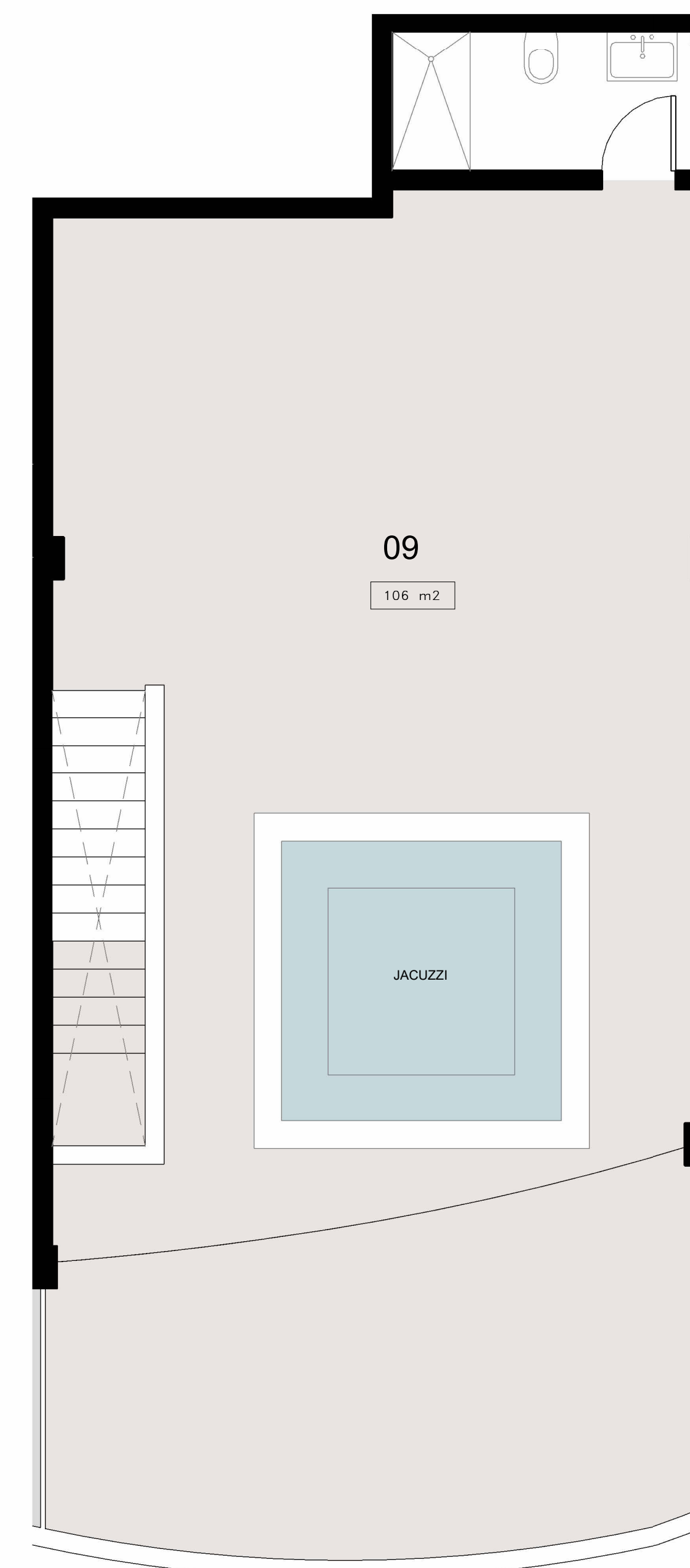

② Bloque A- apt 503 terraza
1 : 50

BLOQUE A
APARTAMENTO 503

DOS HABITACIONES

AREA INTERIOR TOTAL 81 m2

AREA TOTAL TERRAZA 136 m2

AREA TOTAL 217 m2

SITEPLAN

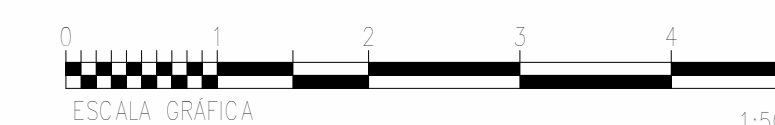
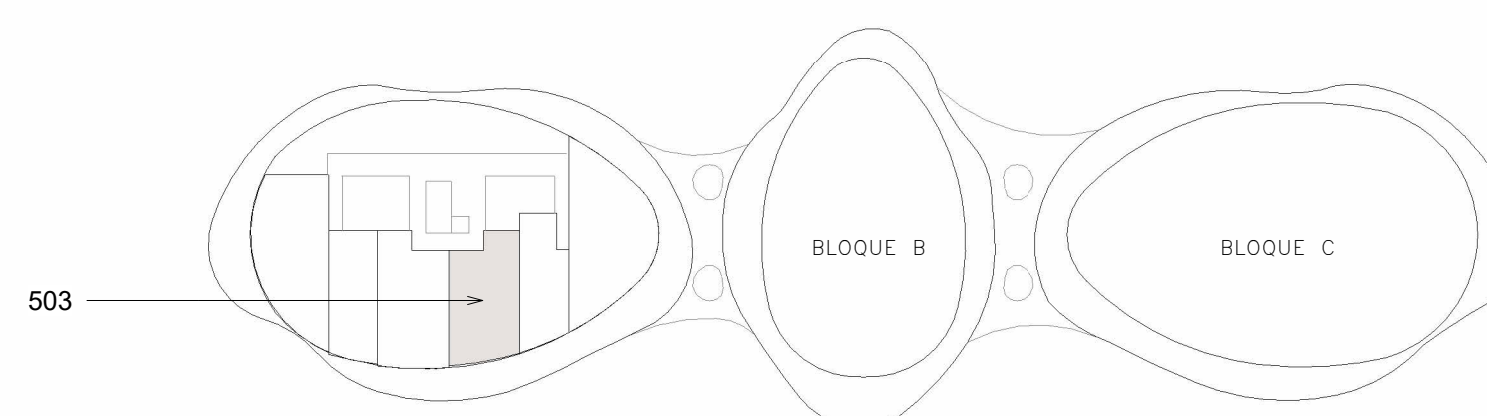

Norte del proyecto



Proyecto:



LE NID

Bayahibe, La Altagracia
Republica Dominicana

Propietario:

Leyenda

- 01 SALA
- 02 COCINA
- 03 COMEDOR
- 04 HABITACION SECUNDARIA
- 05 BAÑO 1
- 06 HABITACION PRINCIPAL
- 07 LAVADORA-SECADORA
- 08 BAÑO 2
- 09 TERRAZA
- 10 BAÑO 3

Equipo de trabajo

Diseño Arquitectonico:
Arq. Frederich Cedano
Codia:
Arq. Colaboradores:
Arq. Gabriela Moreno

Plano

Apartamento 504 - BLOQUE A

A232

Escala

As indicated

Fecha:
AGOSTO
2024

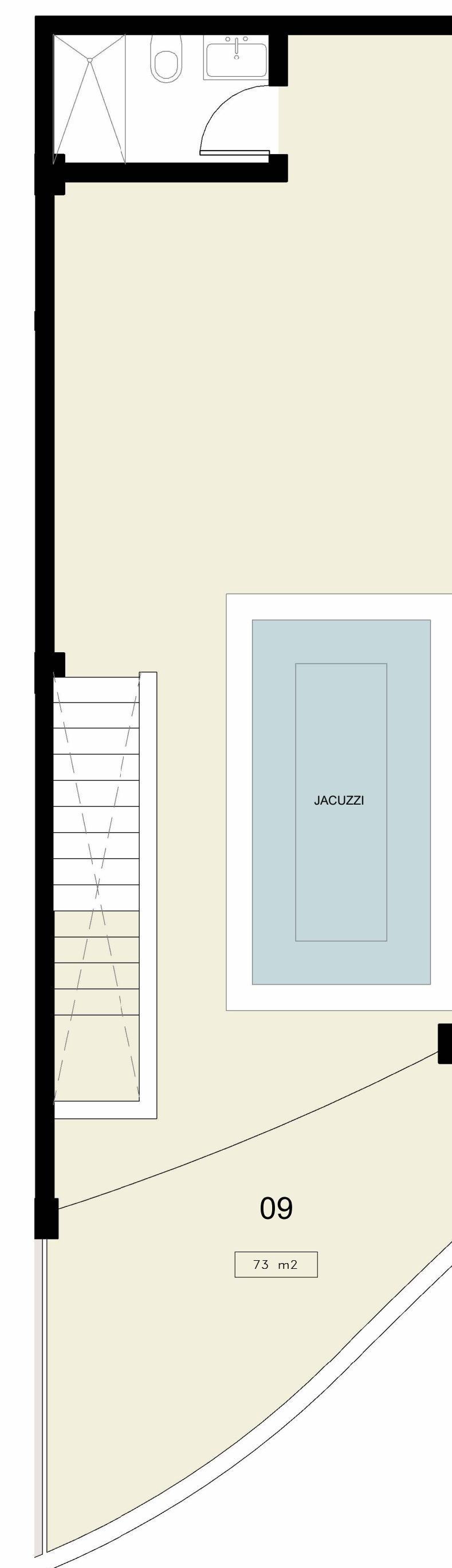
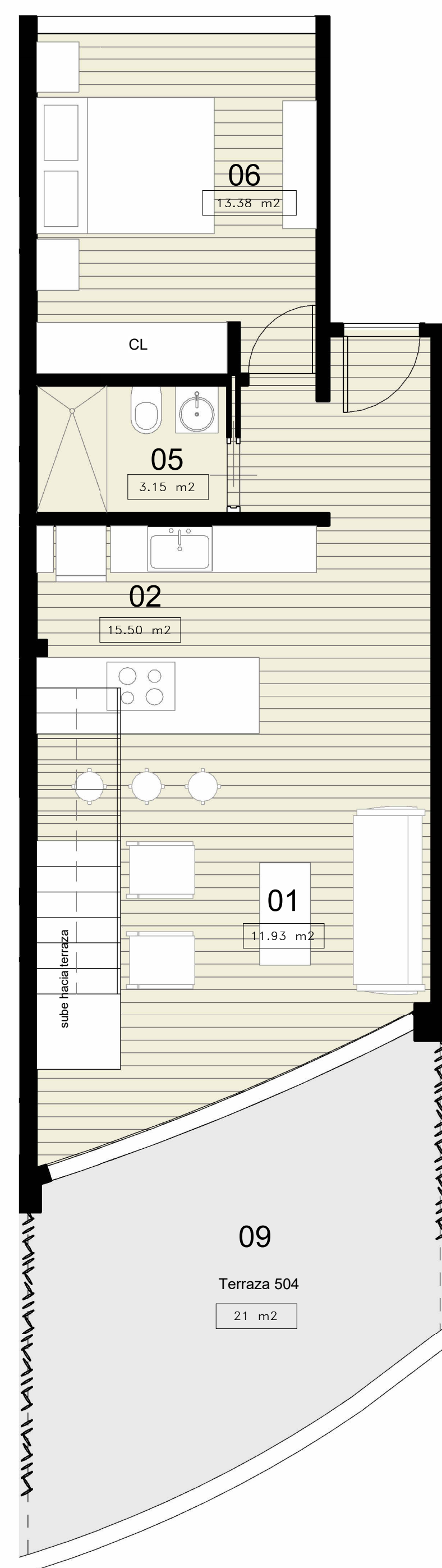

① Bloque A- apt 504 nivel 5
1 : 50

② Bloque A- apt 504 terraza
1 : 50

BLOQUE A
APARTAMENTO 504
DOS HABITACIONES

AREA INTERIOR TOTAL 53 m2
AREA TERRAZA 94 m2
AREA TOTAL 147 m2

SITEPLAN

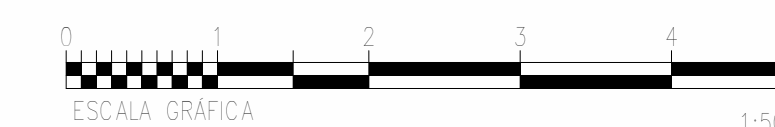
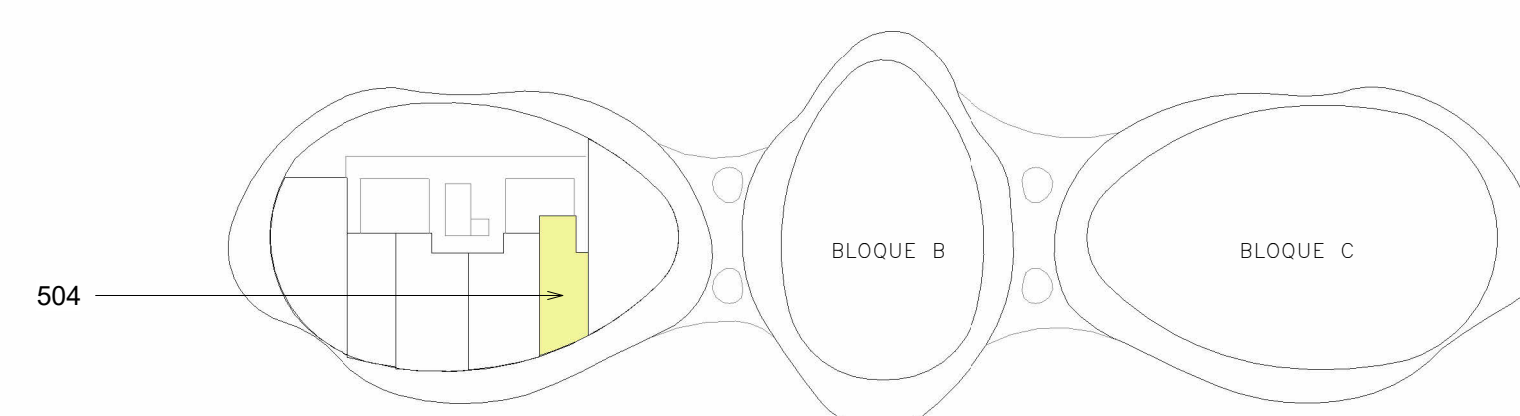

Norte del proyecto



Proyecto:



LE NID

Bayahibe, La Altagracia
Republica Dominicana

Propietario:

Leyenda

- 01 SALA
- 02 COCINA
- 03 COMEDOR
- 04 HABITACION SECUNDARIA
- 05 BAÑO 1
- 06 HABITACION PRINCIPAL
- 07 LAVADORA-SECADORA
- 08 BAÑO 2
- 09 TERRAZA
- 10 BAÑO 3

Equipo de trabajo

Diseño Arquitectonico:

Arq. Frederich Cedano

Codia:

Arq. Colaboradores:

Arq. Gabriela Moreno

Plano

Apartamento 505 - BLOQUE A

A233

Escala

As indicated

Fecha:
AGOSTO
2024

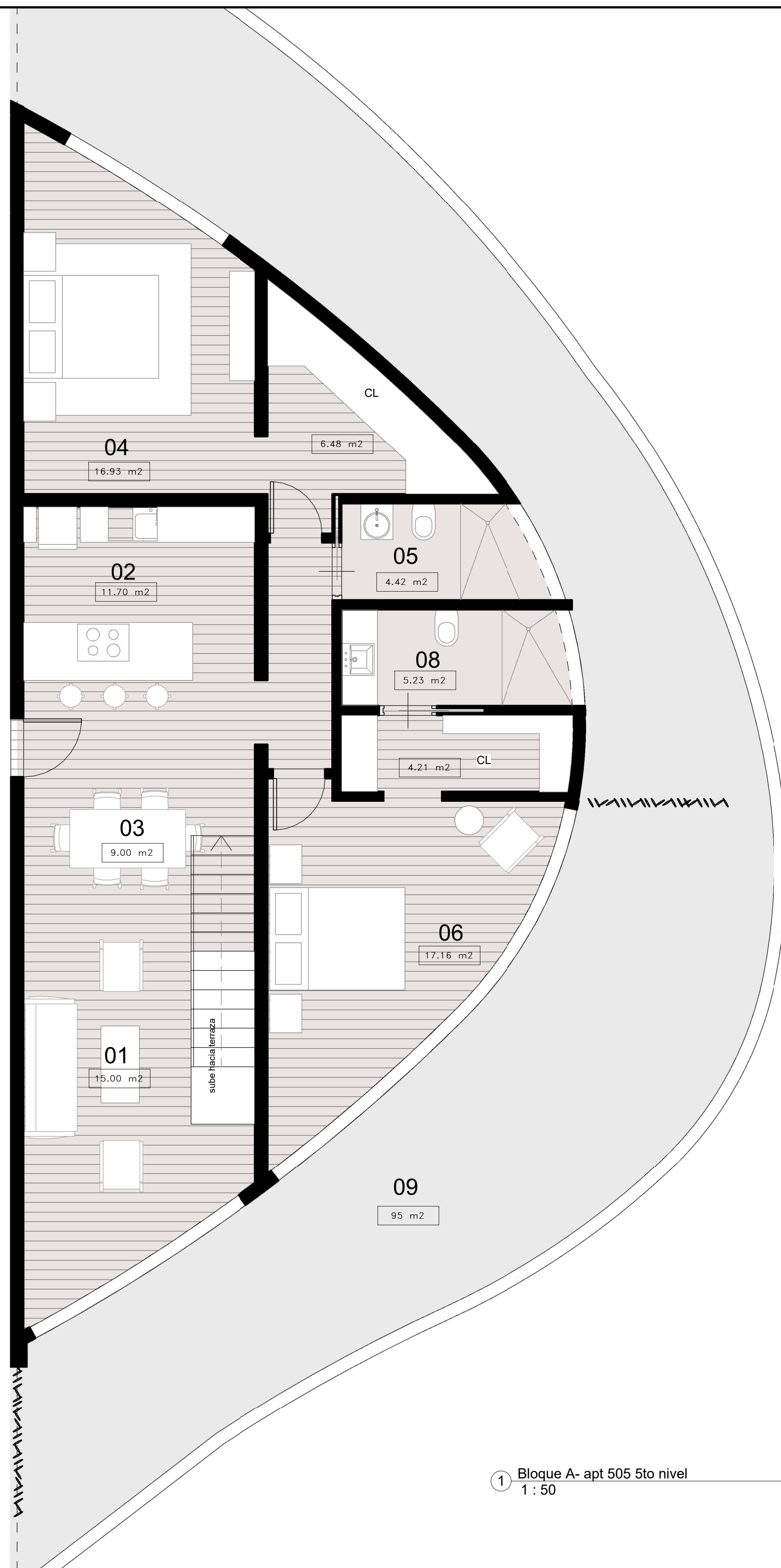

① Bloque A- apt 505 5to nivel
1 : 50

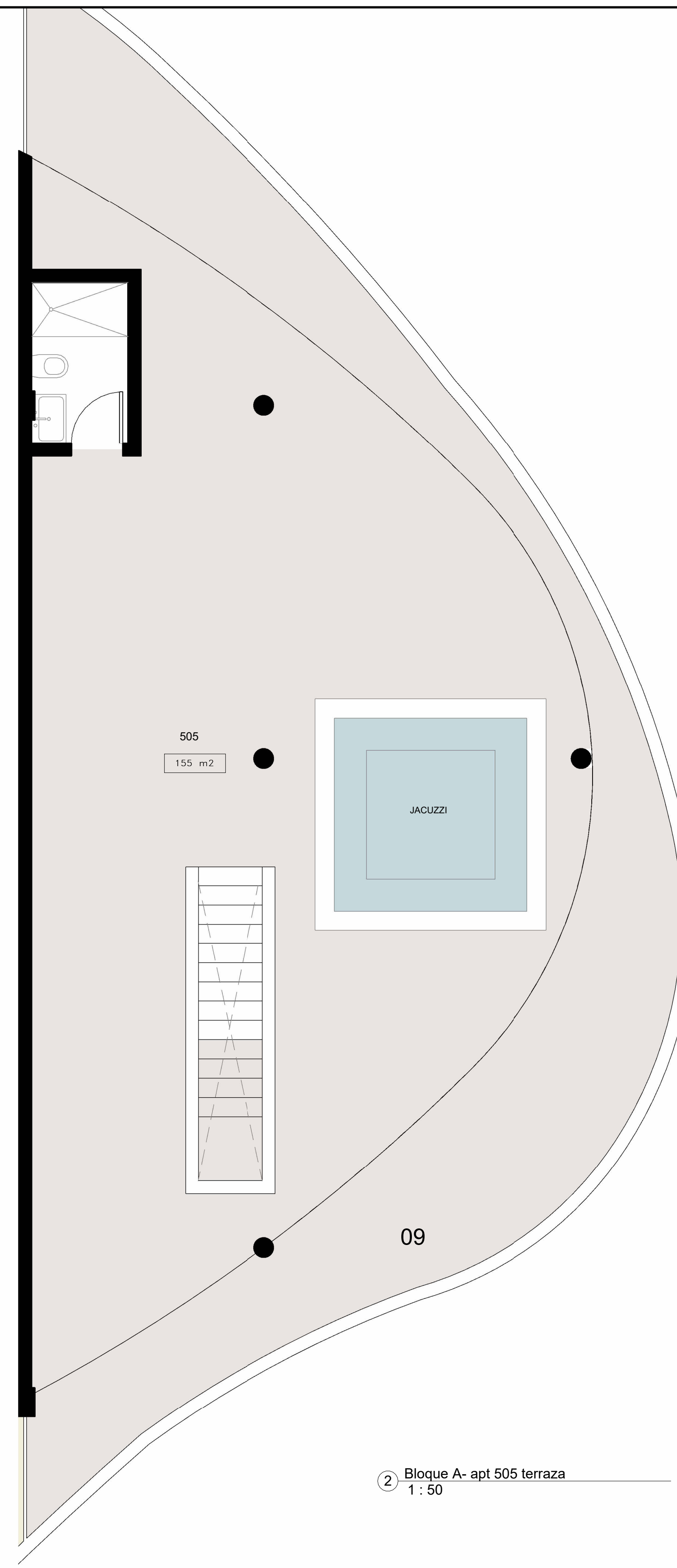

② Bloque A- apt 505 terraza
1 : 50

BLOQUE A
APARTAMENTO 505

DOS HABITACIONES

AREA INTERIOR TOTAL 107 m2

AREA TERRAZA 250 m2

AREA TOTAL 357 m2

SITEPLAN

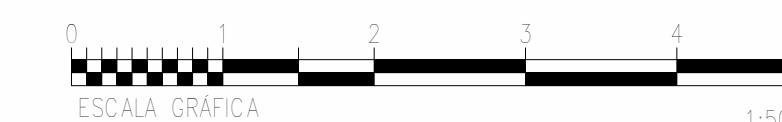
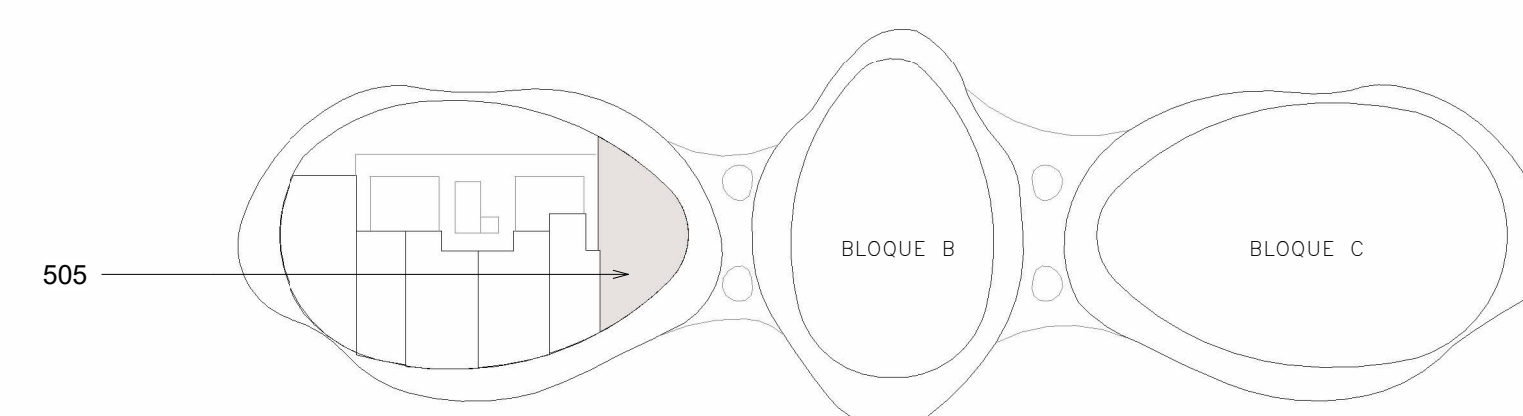

Norte del proyecto



Proyecto:



LE NID

Bayahibe, La Altagracia
Republica Dominicana

Propietario:

Leyenda

- 01 SALA
- 02 COCINA
- 03 COMEDOR
- 04 HABITACION SECUNDARIA
- 05 BAÑO 1
- 06 HABITACION PRINCIPAL
- 07 LAVADORA-SECADORA
- 08 BAÑO 2
- 09 TERRAZA
- 10 BAÑO 3

Equipo de trabajo

Diseño Arquitectonico:

Arq. Frederich Cedano

Codia:

Arq. Colaboradores:

Arq. Gabriela Moreno

Plano

Apartamento 506 - BLOQUE A

A234

Escala

As indicated

Fecha:
AGOSTO
2024

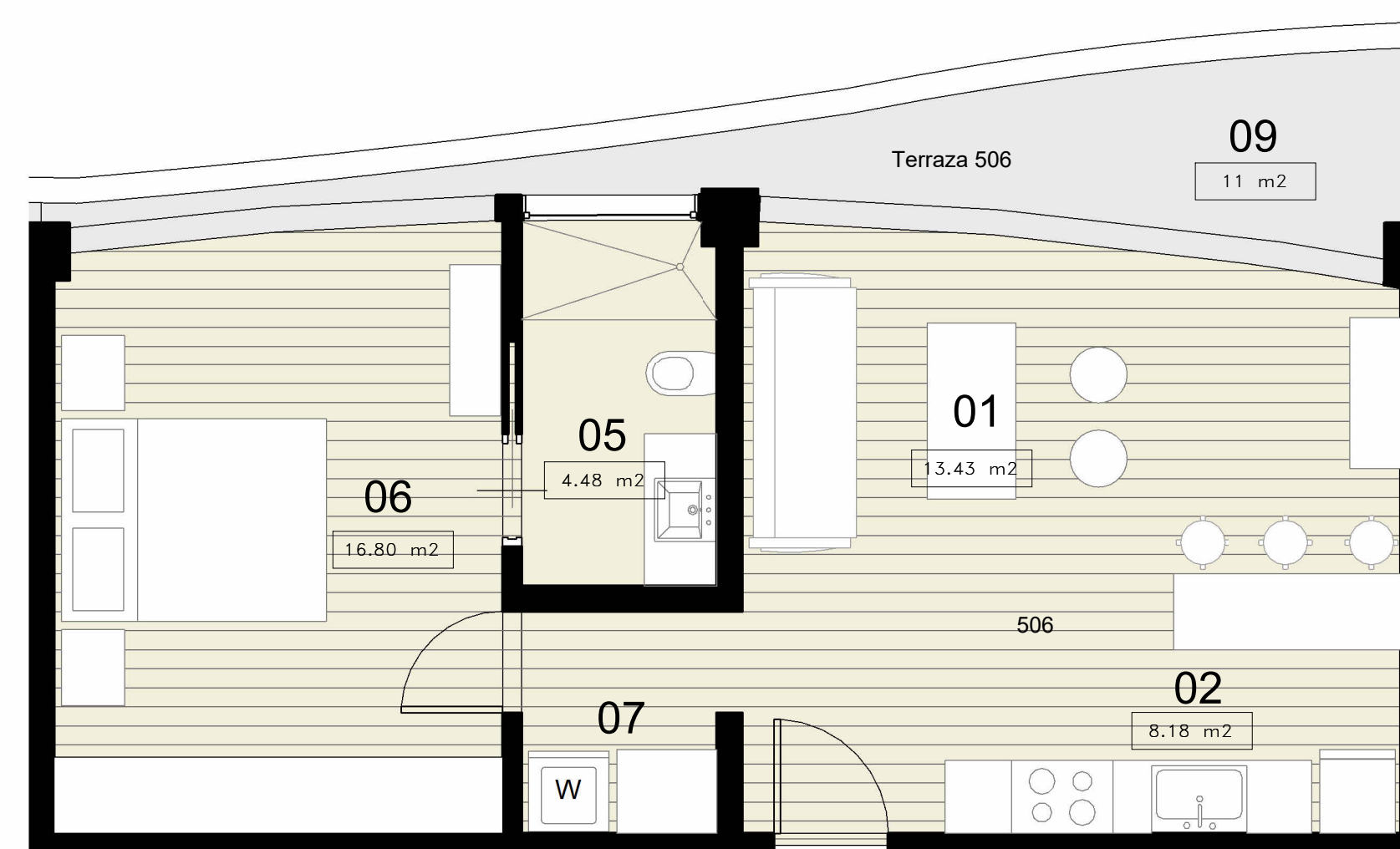

BLOQUE A
APARTAMENTO 506

UNA HABITACION

AREA INTERIOR TOTAL 50 m2

AREA TERRAZA 9 m2

AREA TOTAL 59 m2

SITEPLAN

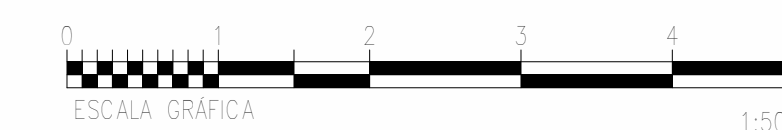
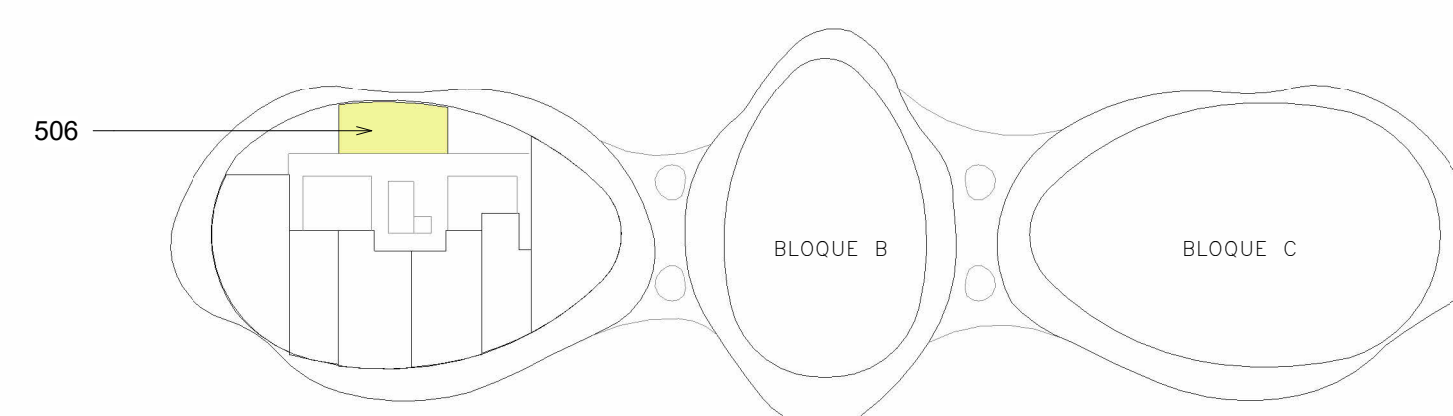

① BLOQUE A- apt 506
1:50