

Schedule 'A'
652 PRINCESS STREET, KINGSTON, ON.

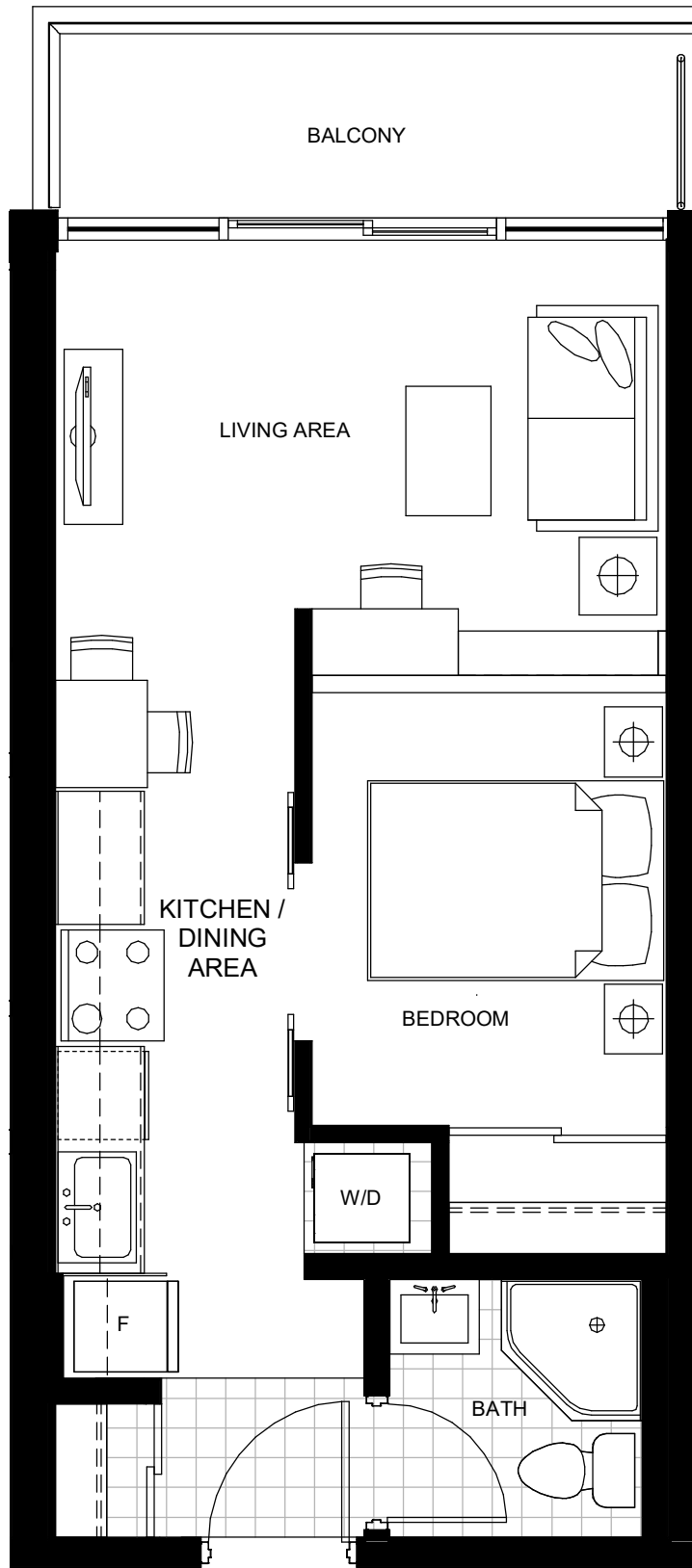

UNIT TYPE 1B10 446.33 SF

UNITS: 624, 626
724, 726
824, 826
922, 924

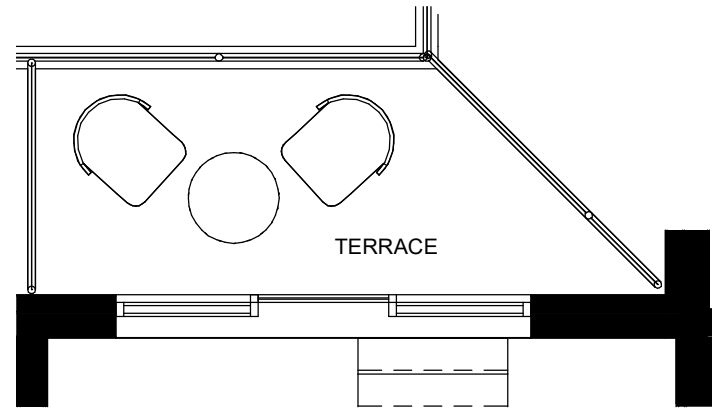

UNITS: 523
AREA: 458.02 SF

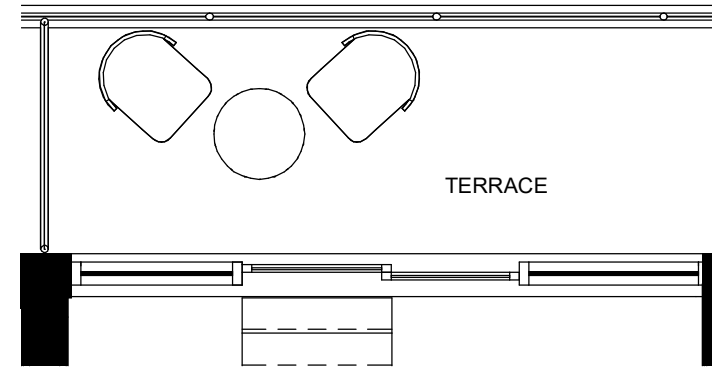

UNITS: 524, 525, 526

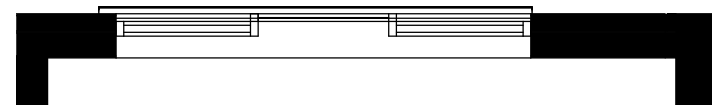

UNITS: 1022, 1023, 1024

UNITS: 623, 723, 823, 921, 1021
AREA: 458.02 SF

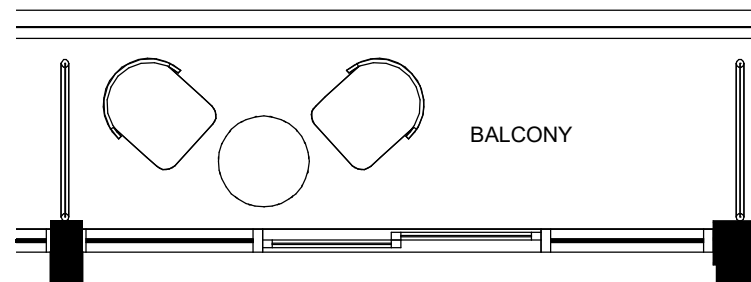

UNITS: 625
725
825
923

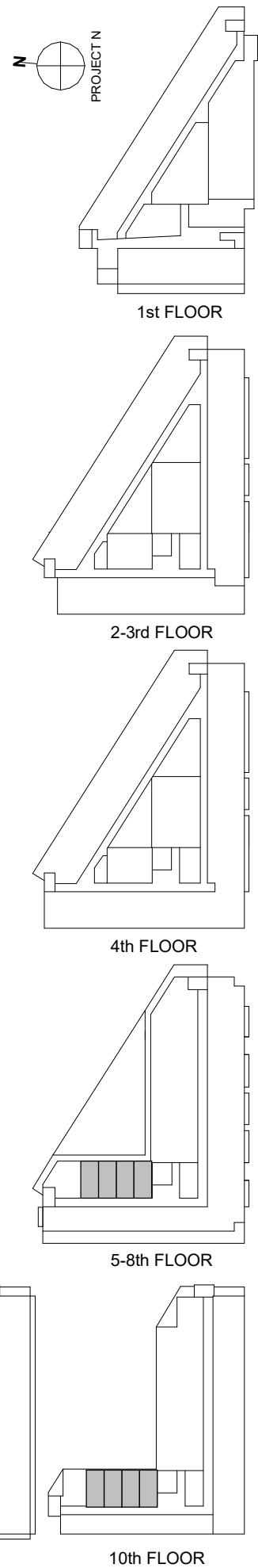

Schedule 'A'
652 PRINCESS STREET, KINGSTON, ON.

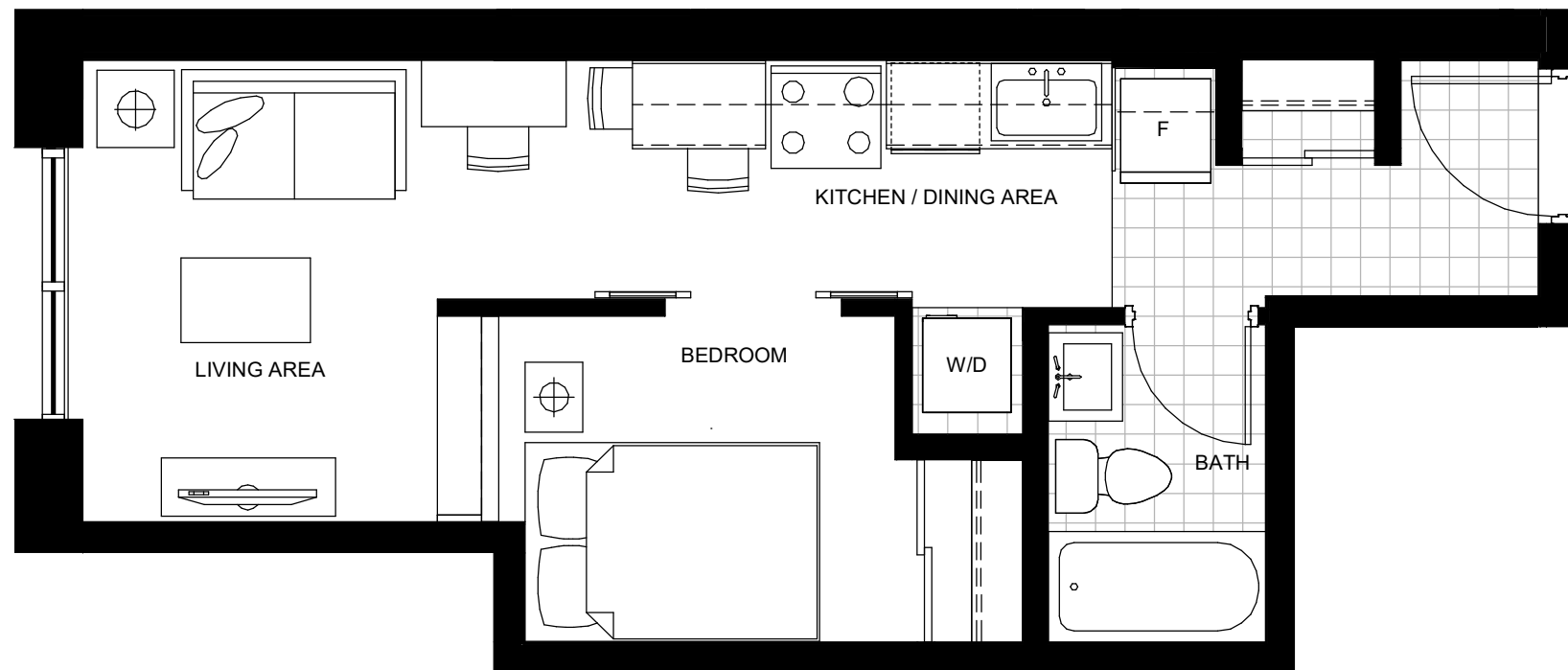

UNITS: 215, 217, 219, 221, 223
315, 317, 319, 321, 323
415, 417, 419, 421, 423

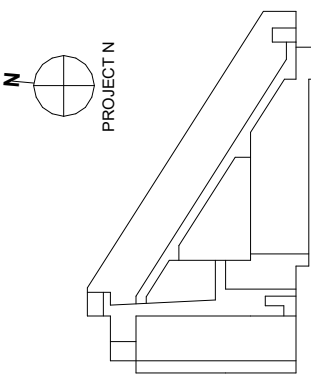

1st FLOOR

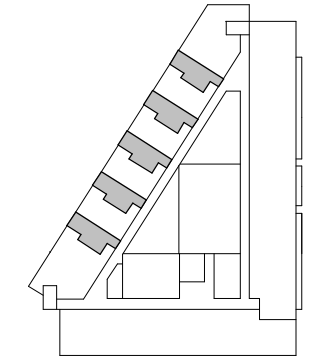

2-3rd FLOOR

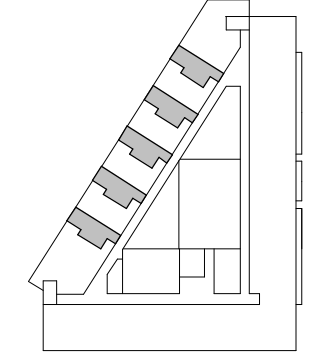

4th FLOOR

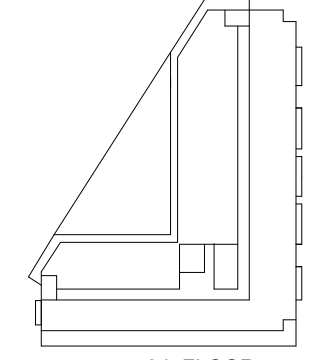

5-8th FLOOR

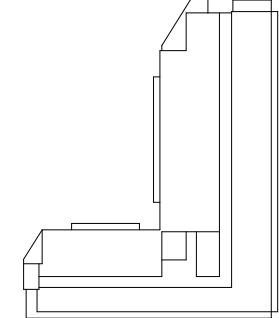

9th FLOOR

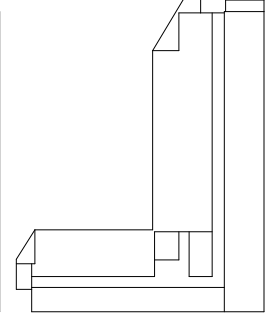

10th FLOOR

UNIT TYPE 1B11 412.22 SF

Schedule 'A'
652 PRINCESS STREET, KINGSTON, ON.

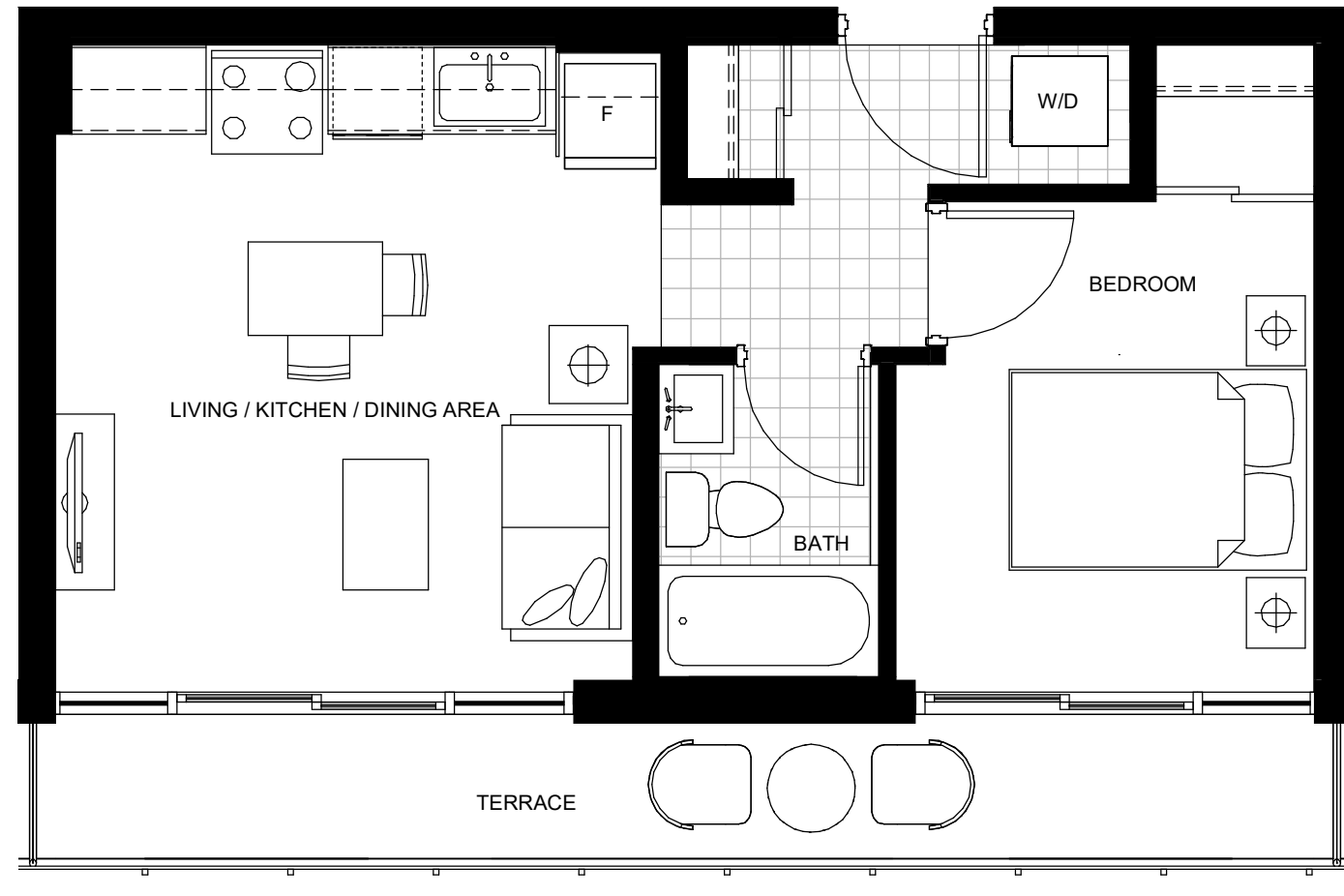

UNITS: 927, 928, 930



UNITS: 1027, 1028, 1030

UNIT TYPE 1B12 469.41 SF

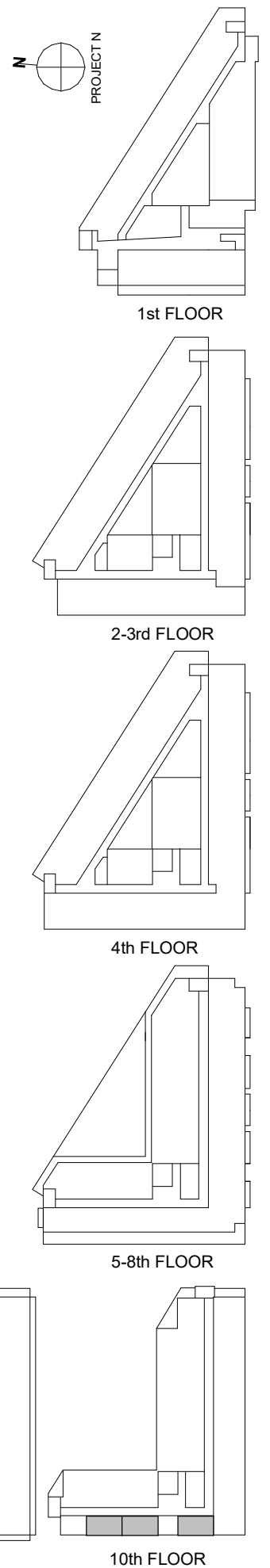

Schedule 'A'
652 PRINCESS STREET, KINGSTON, ON.

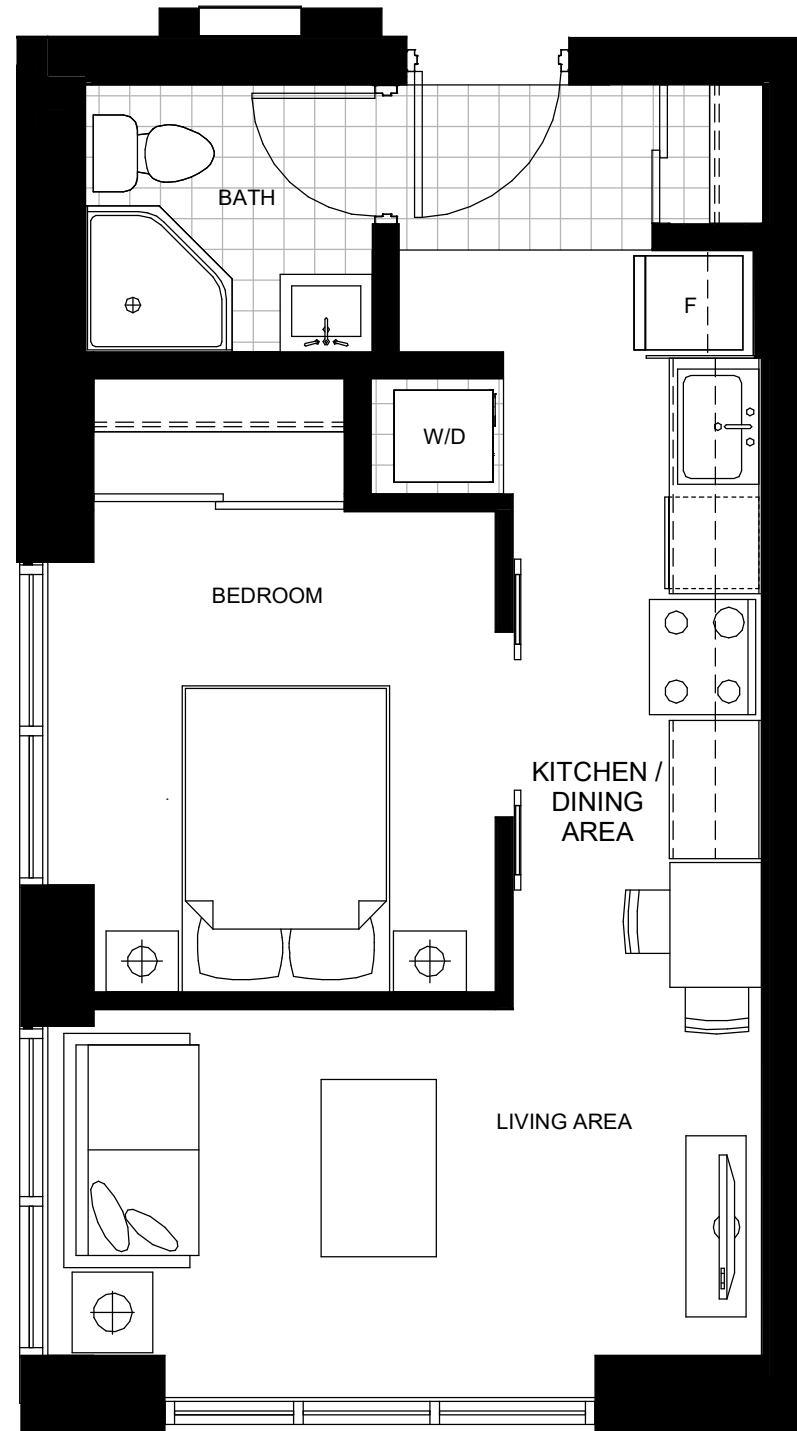

UNITS: 226,
326,
426 AREA: 502.12 SF

UNIT TYPE 1B13 500.49 SF

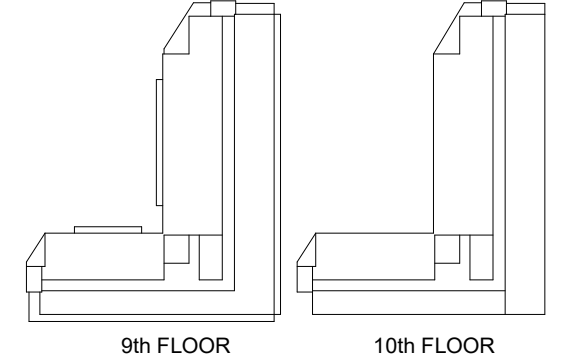
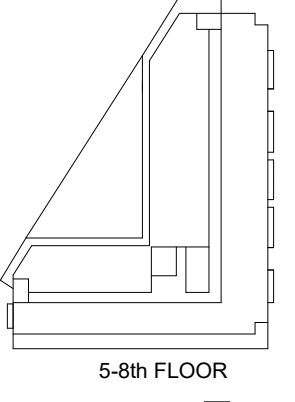
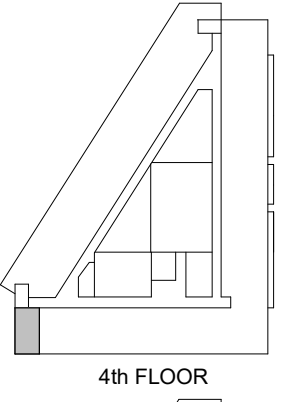
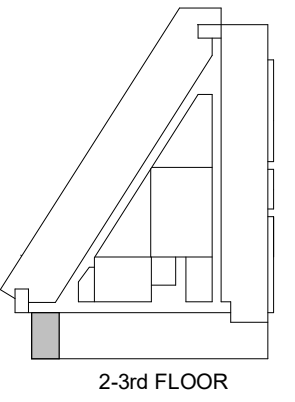
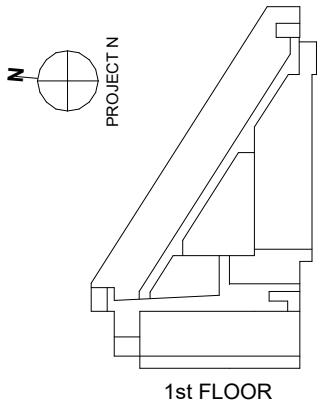

Schedule 'A'
652 PRINCESS STREET, KINGSTON, ON.

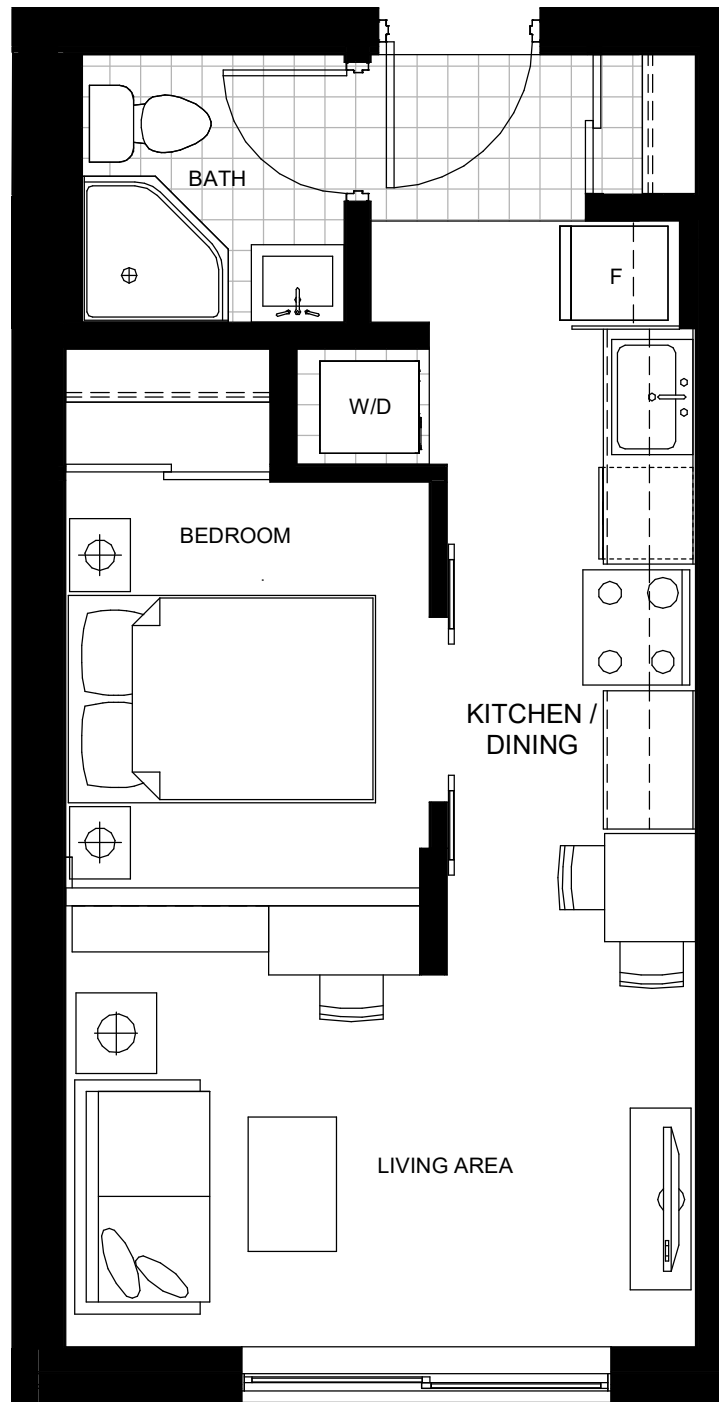

UNITS: 227, 228, 229, 230, 232, 233
327, 328, 329, 330, 332, 333
427, 428, 429, 430, 431, 433, 434

UNIT TYPE 1B2 446.28 SF

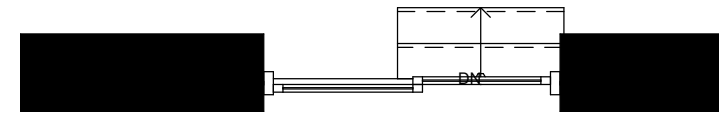

2R IN UNIT 101&102
1R IN UNIT 103&104

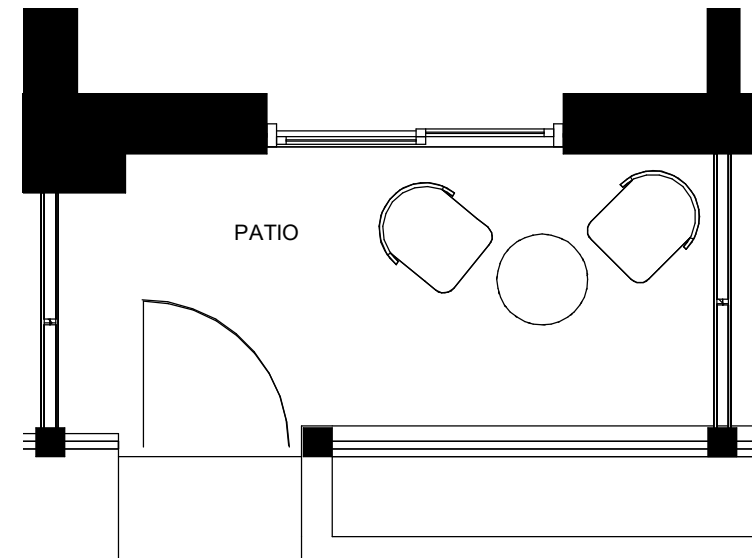

UNITS: 101 AREA: 464.33 SF
UNITS: 102, 103, 104 AREA: 446.28 SF
UNITS: 106 AREA: 444.29 SF
UNITS: 107 AREA: 480.06 SF

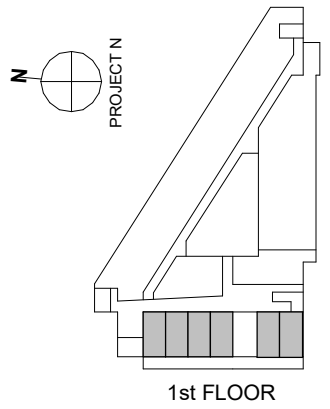

1st FLOOR

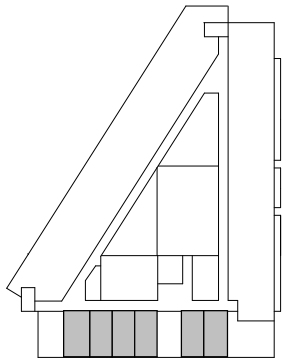

2-3rd FLOOR

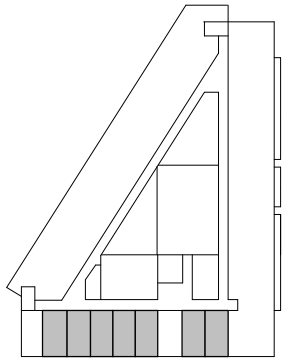

4th FLOOR

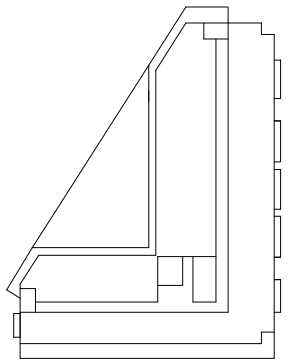

5-8th FLOOR

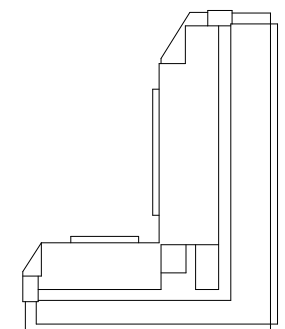

9th FLOOR

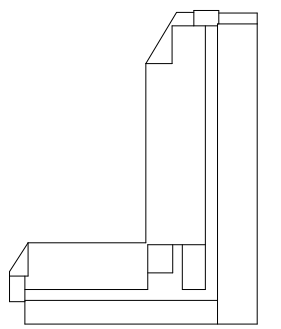

10th FLOOR

Schedule 'A'

652 PRINCESS STREET, KINGSTON, ON.

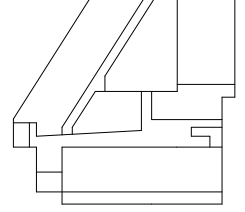

1st FLOOR

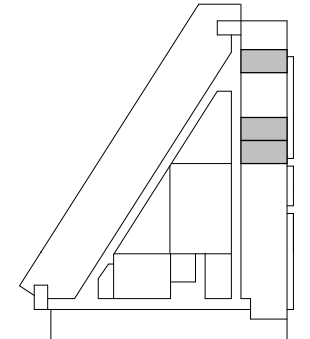

2-3rd FLOOR

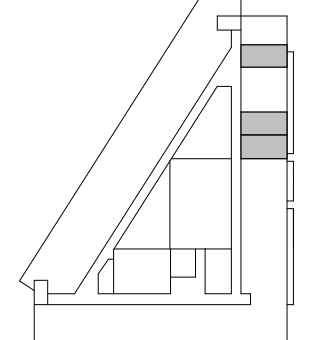

4th FLOOR

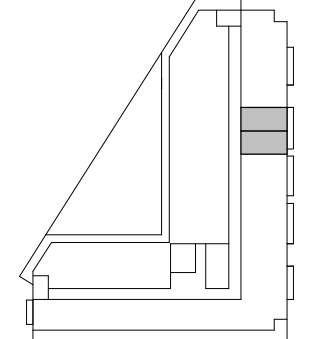

5-8th FLOOR

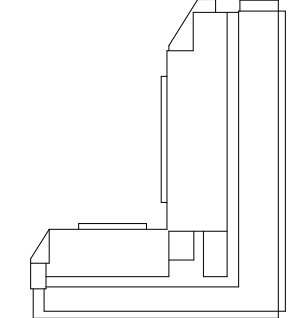

9th FLOOR

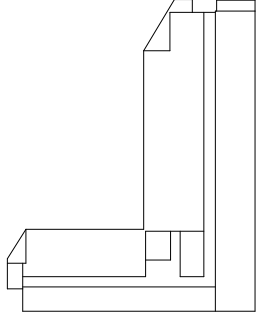

10th FLOOR



UNITS: 207, 211
307, 311
407, 411

507, 508 AREA: 456.22 SF
607, 608 AREA: 456.22 SF
707, 708 AREA: 456.22 SF
807, 808 AREA: 456.22 SF

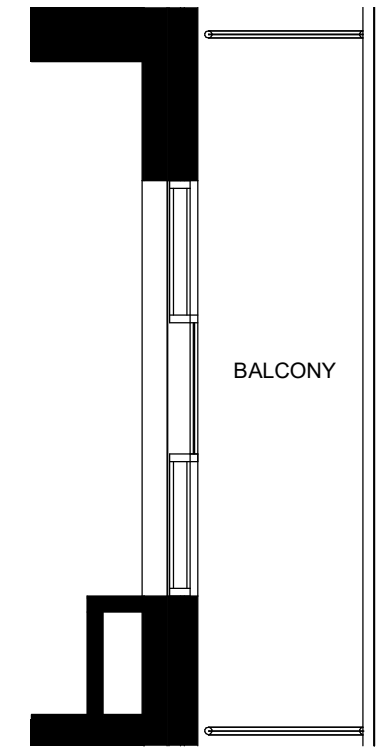

UNITS: 208,
308,
408,

UNIT TYPE 1B5 461.32 SF

Schedule 'A'
652 PRINCESS STREET, KINGSTON, ON.

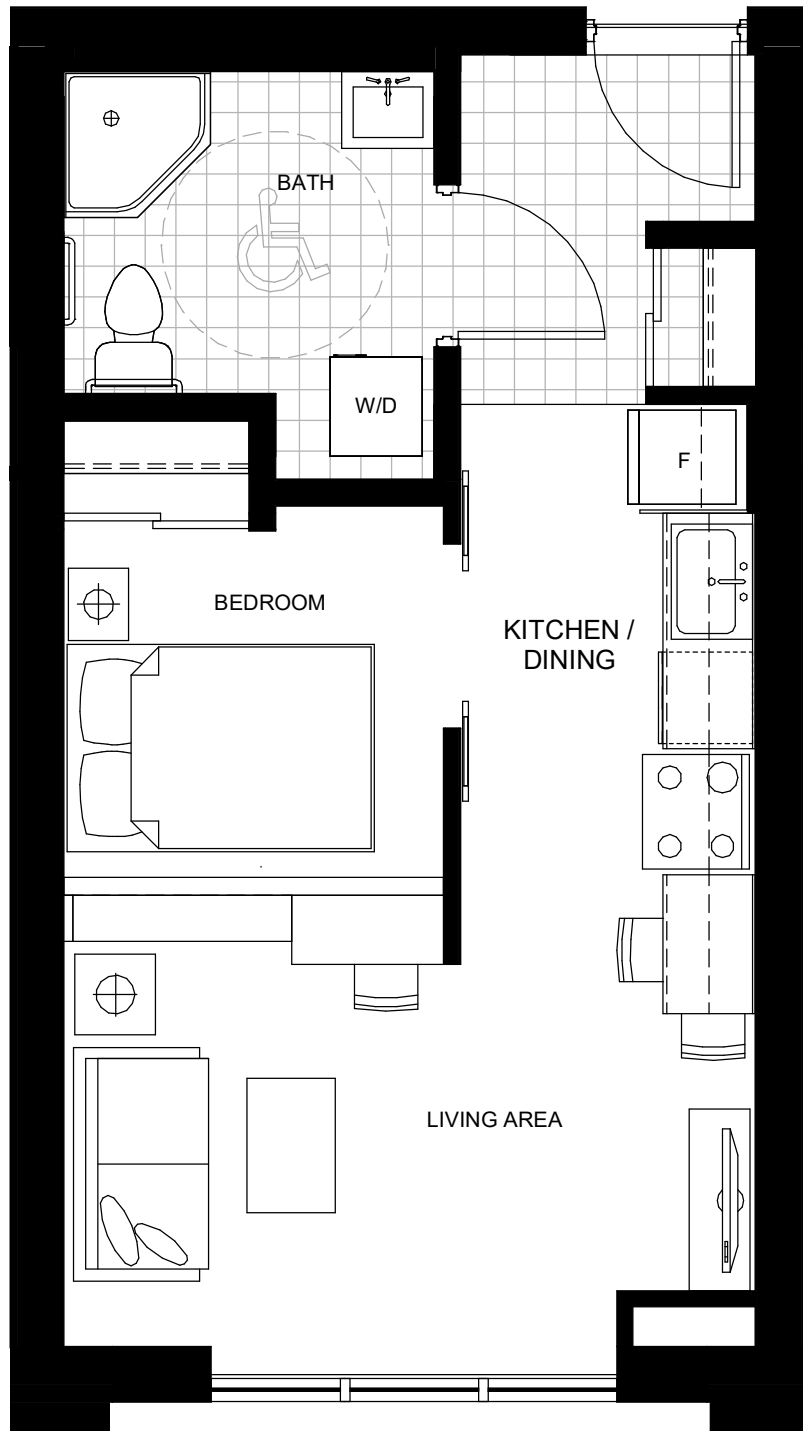

UNITS: 231, 331,
432

UNIT TYPE 1B6

488.61 SF

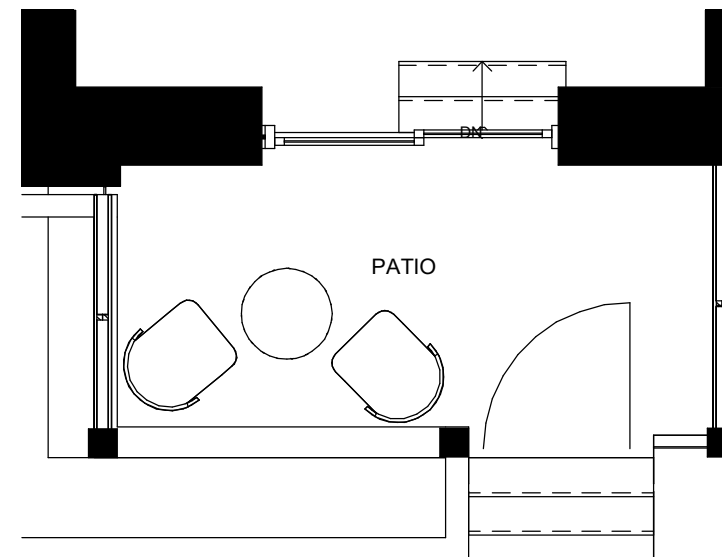

UNIT: 105 AREA: 493.92 SF

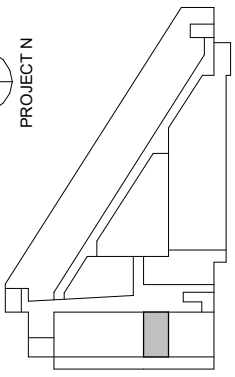

1st FLOOR

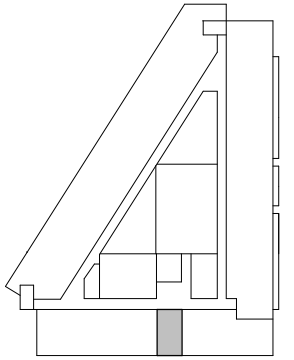

2-3rd FLOOR

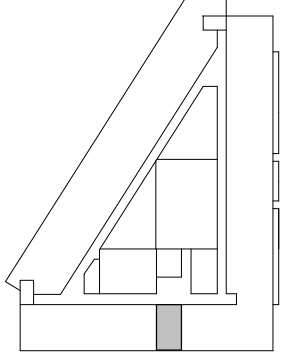

4th FLOOR

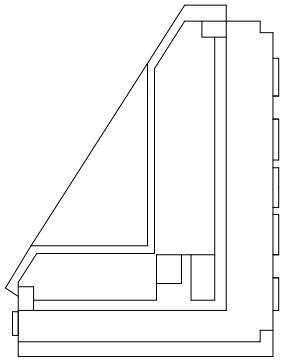

5-8th FLOOR

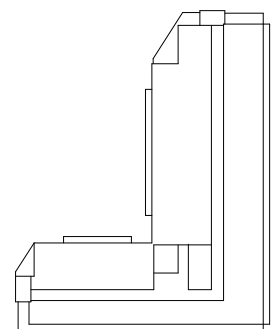

9th FLOOR

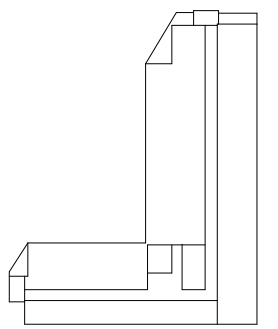

10th FLOOR

Schedule 'A'
652 PRINCESS STREET, KINGSTON, ON.

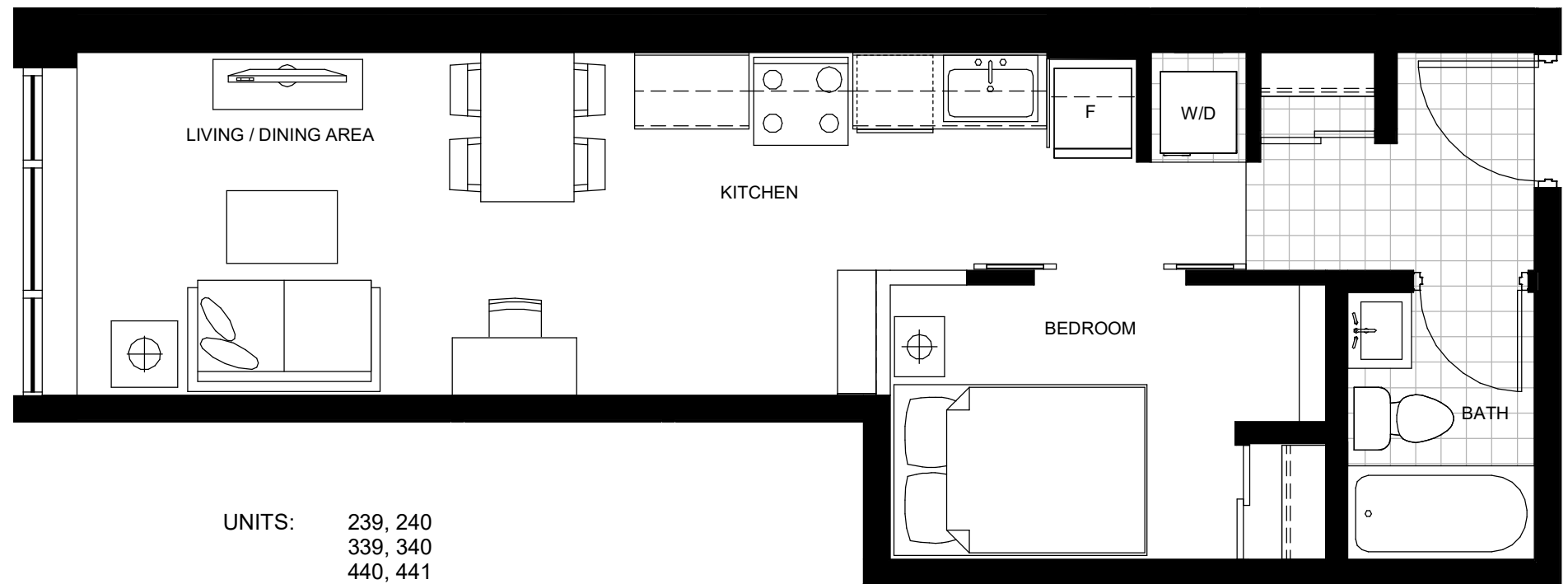

UNITS: 239, 240
339, 340
440, 441

1st FLOOR

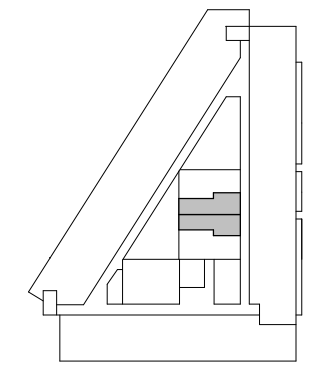

2-3rd FLOOR

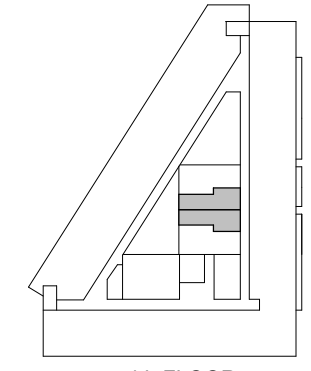

4th FLOOR

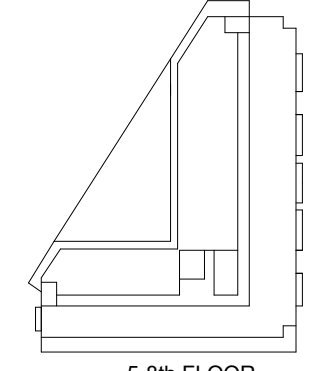

5-8th FLOOR

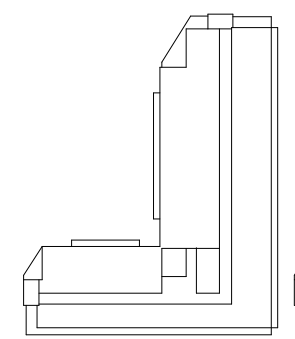

9th FLOOR

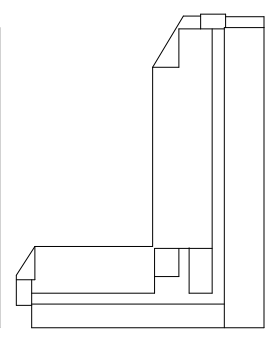

10th FLOOR

UNIT TYPE 1B8 481.78 SF

Schedule 'A'
652 PRINCESS STREET, KINGSTON, ON.

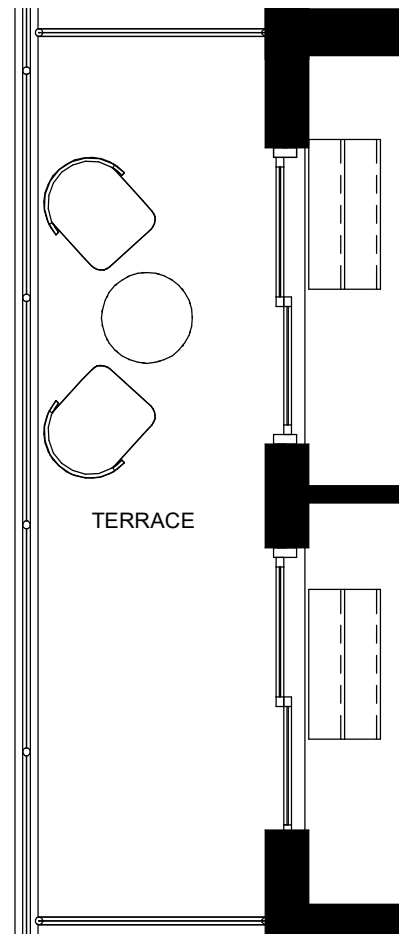
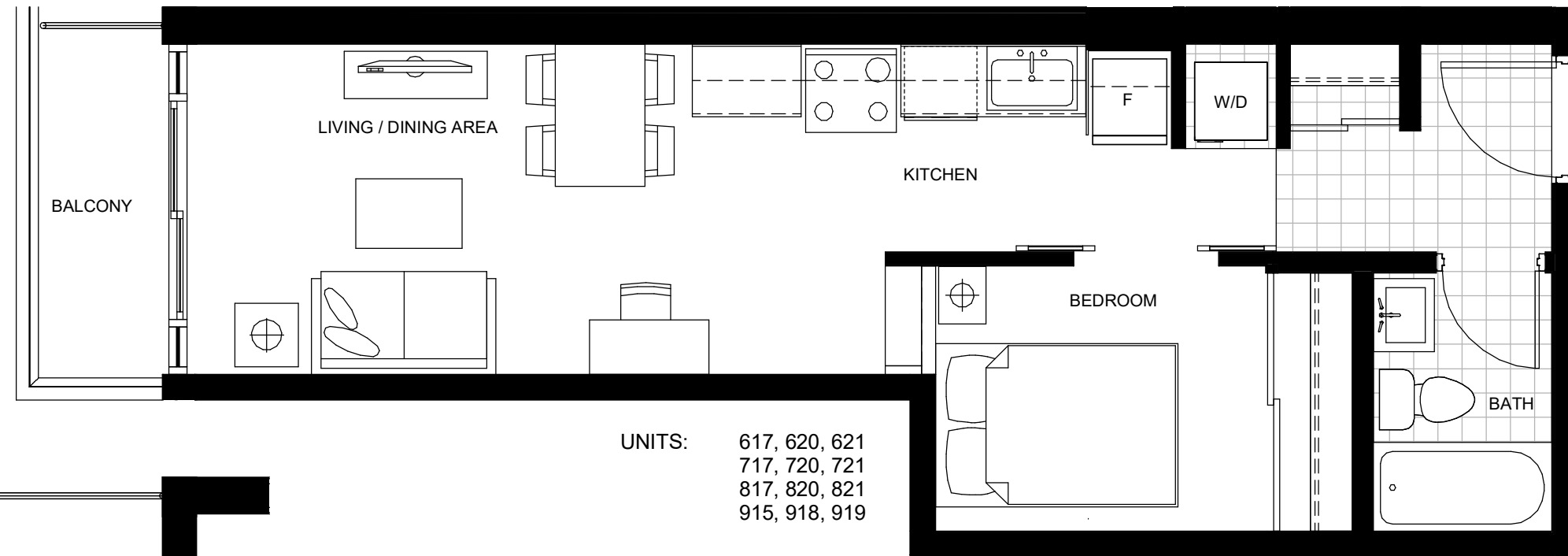

UNITS: 515, 517, 520, 521

UNIT TYPE 1B9 465.35 SF

UNITS: 615,
715,
815,
1015, 1018, 1019

UNITS: 913, 1013
AREA: 482.14 SF

1st FLOOR

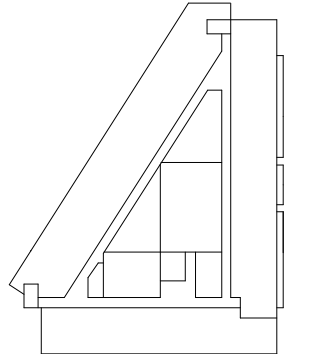

2-3rd FLOOR

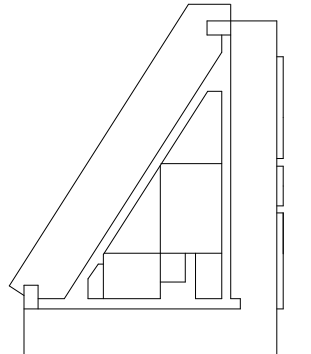

4th FLOOR

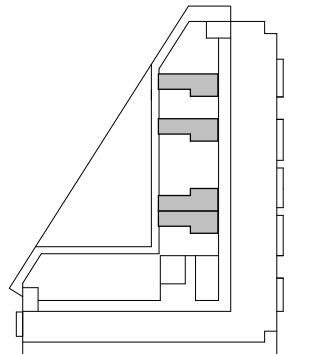

5-8th FLOOR

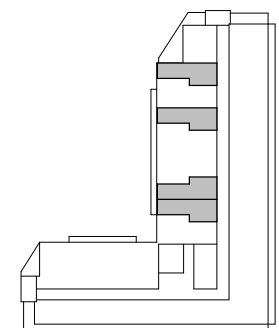

9th FLOOR

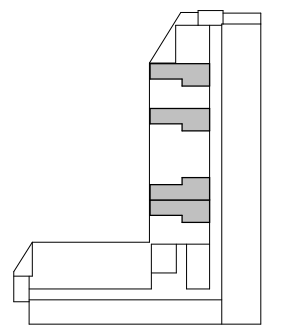

10th FLOOR

Schedule 'A'
652 PRINCESS STREET, KINGSTON, ON.

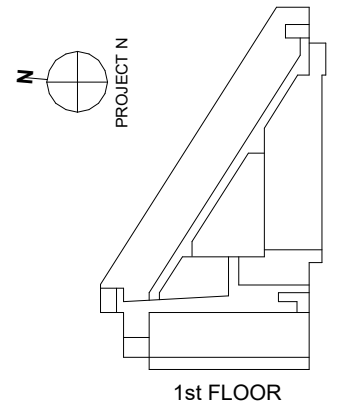

1st FLOOR

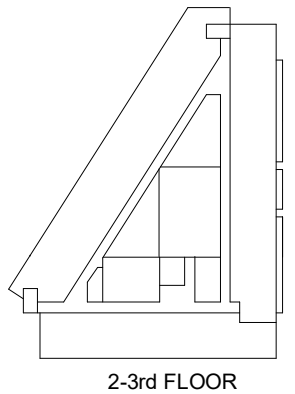

2-3rd FLOOR

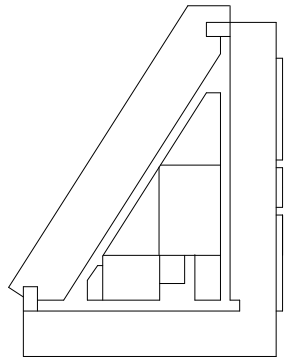

4th FLOOR

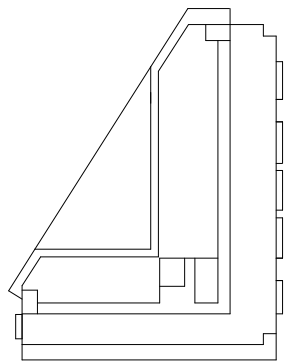

5-8th FLOOR

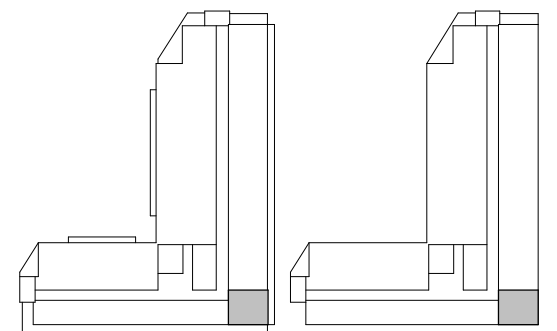

9th FLOOR

10th FLOOR

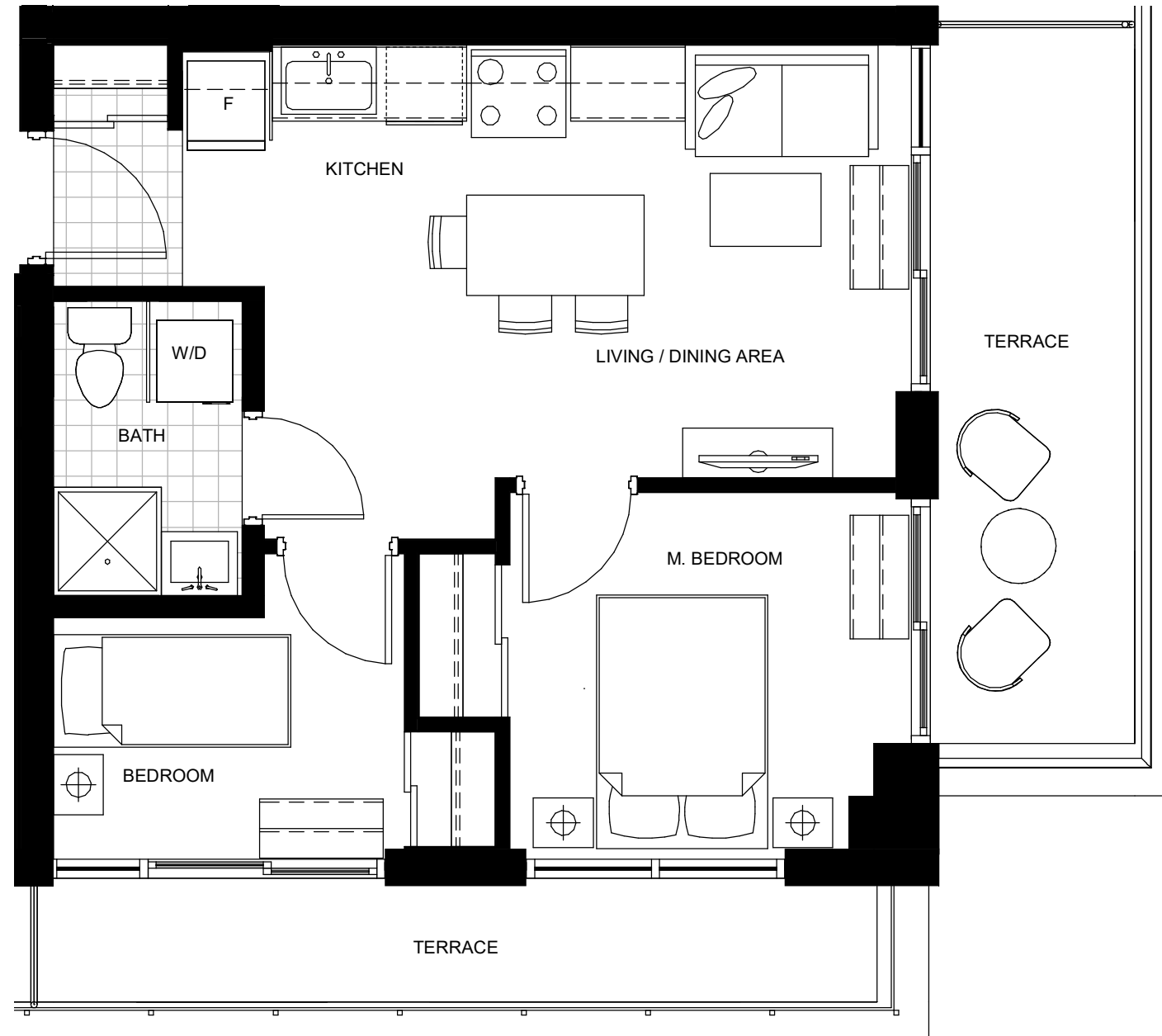

UNIT: 931



UNIT: 1031

UNIT TYPE 2B15 534.08 SF

Schedule 'A'
652 PRINCESS STREET, KINGSTON, ON.

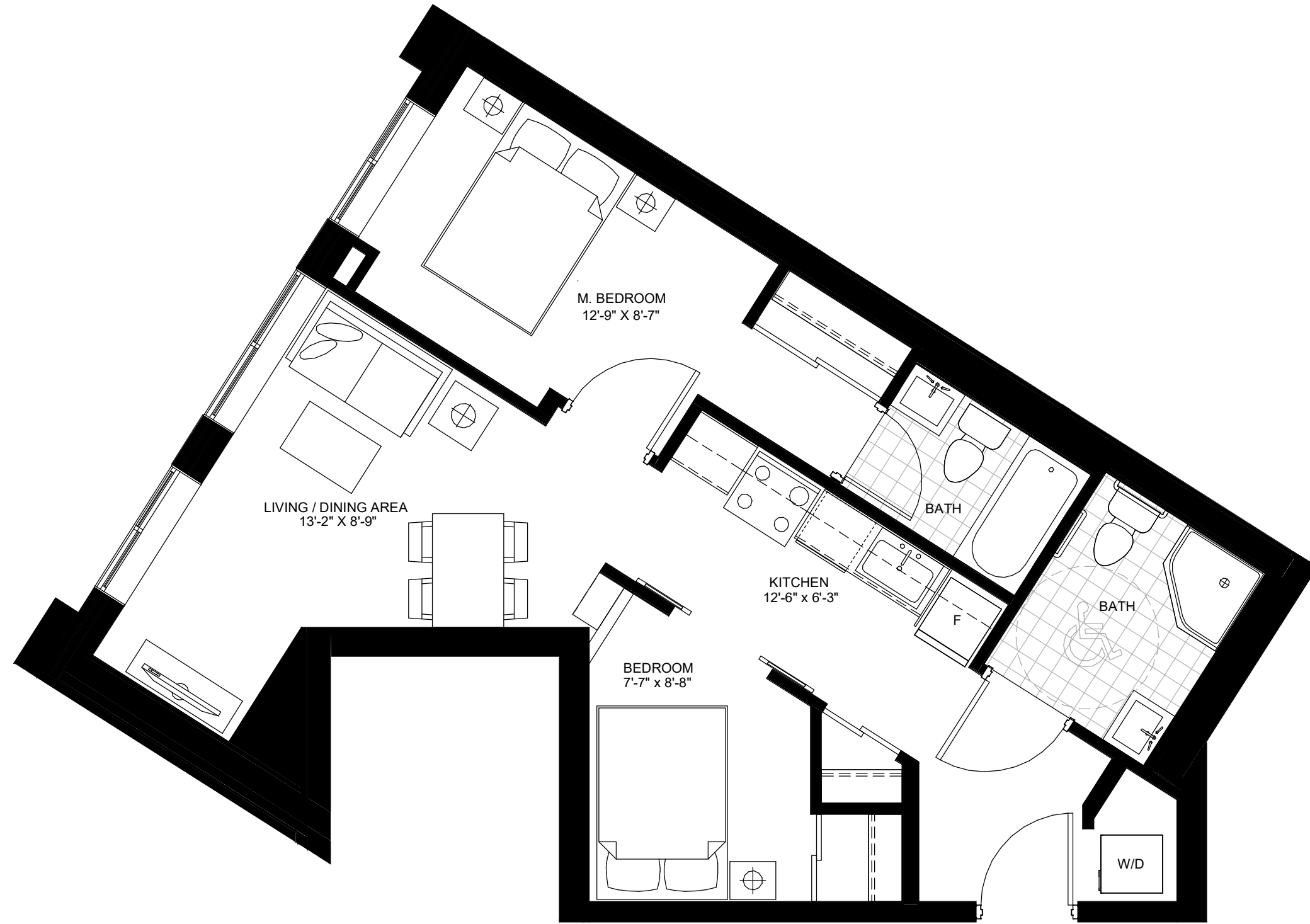

UNITS: 225, 325, 425

UNIT TYPE 2B16 747.77 SF

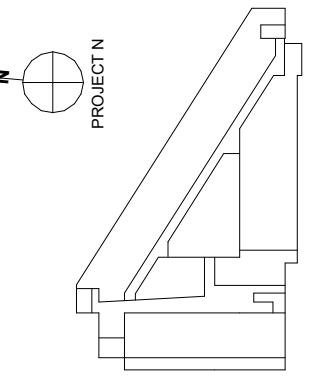

1st FLOOR

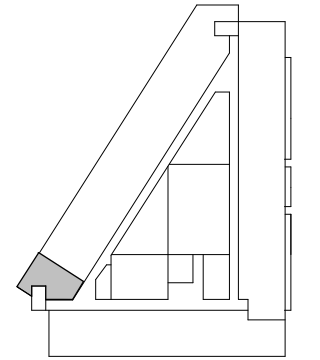

2-3rd FLOOR

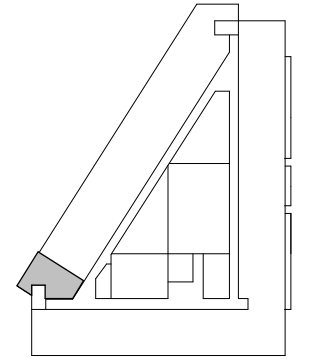

4th FLOOR

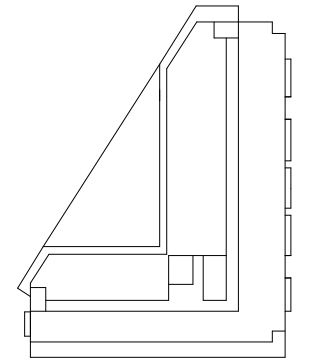

5-8th FLOOR

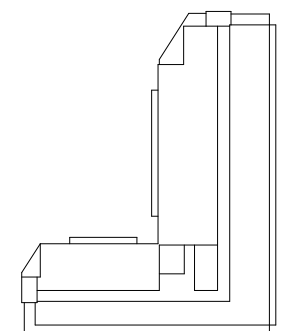

9th FLOOR

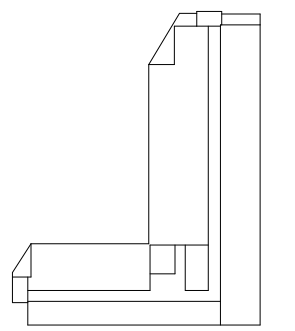

10th FLOOR

Schedule 'A'
 652 PRINCESS STREET, KINGSTON, ON.

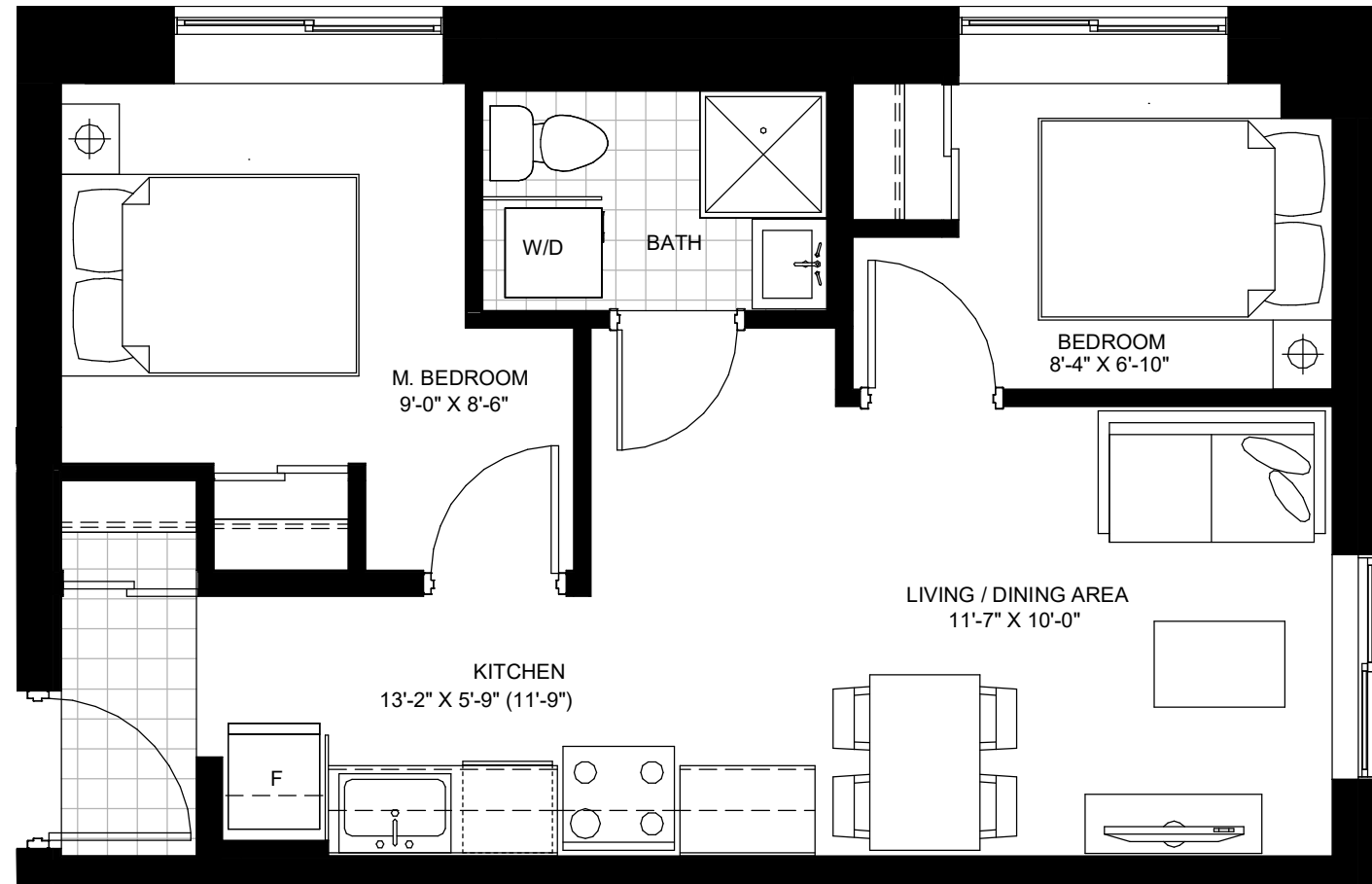
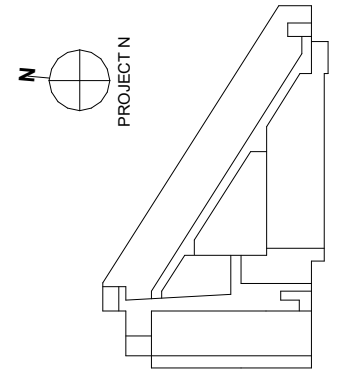

UNITS: 212
 312
 412

UNIT TYPE 2B17 587.72 SF

1st FLOOR

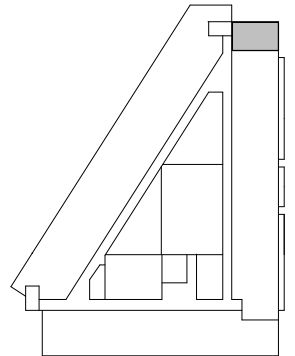

2-3rd FLOOR

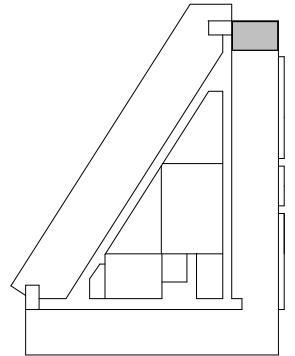

4th FLOOR

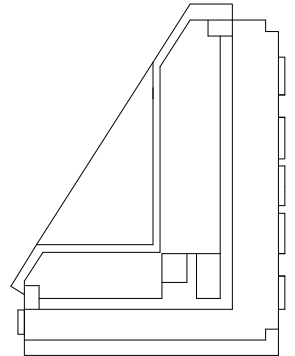

5-8th FLOOR

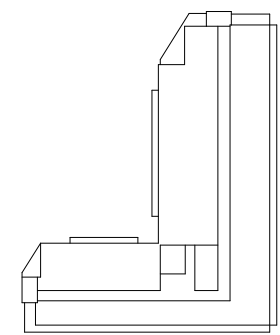

9th FLOOR

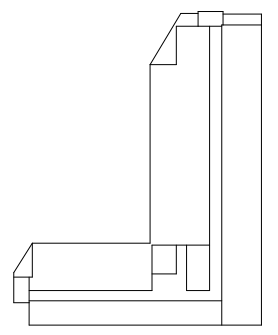

10th FLOOR

Schedule 'A'
652 PRINCESS STREET, KINGSTON, ON.

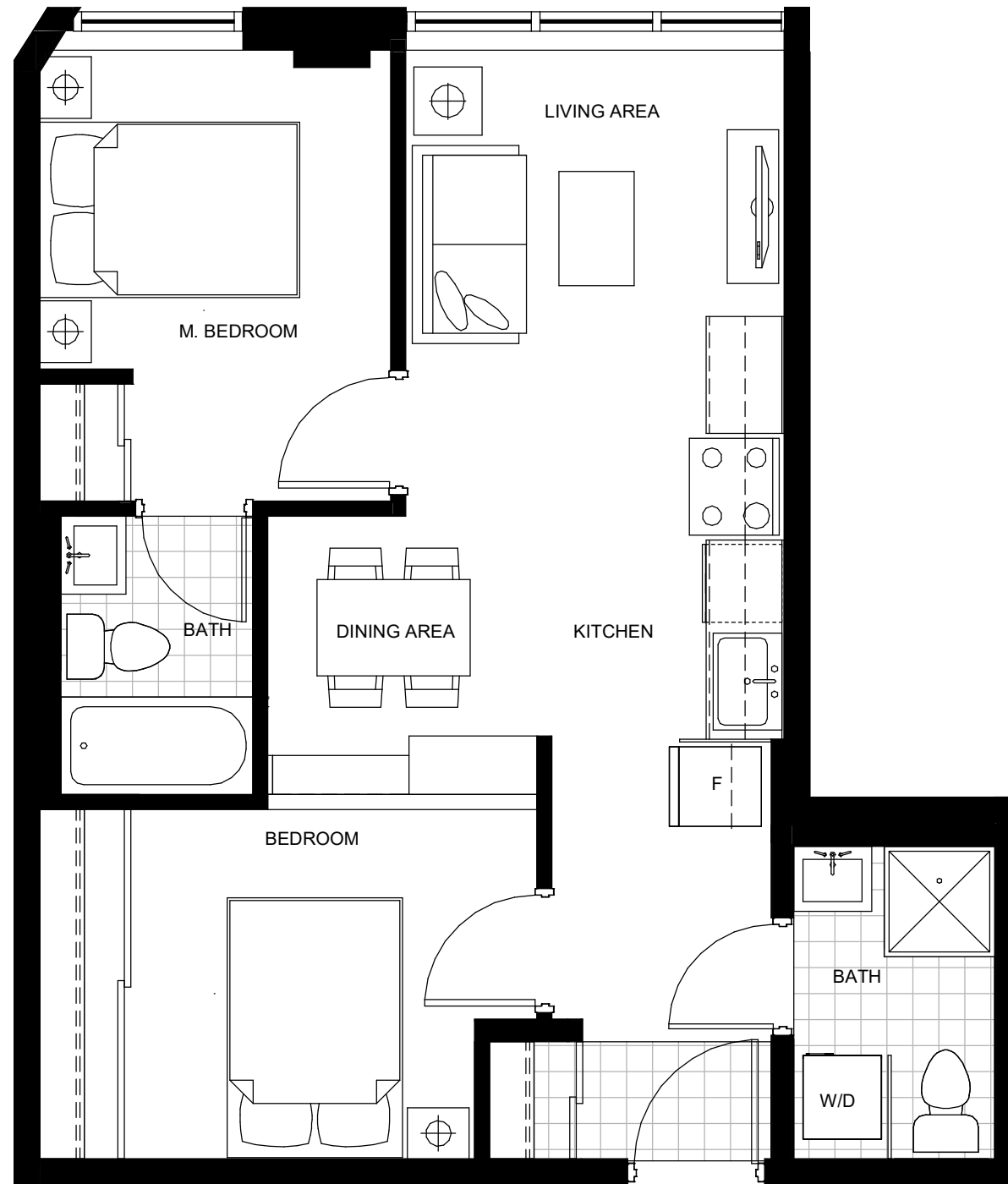

UNITS: 236, 336, 437

UNIT TYPE 2B3 660.56 SF

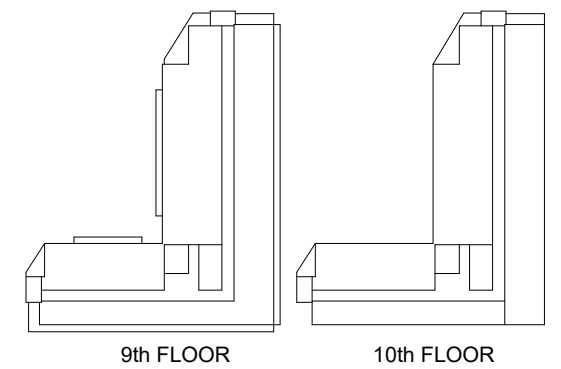
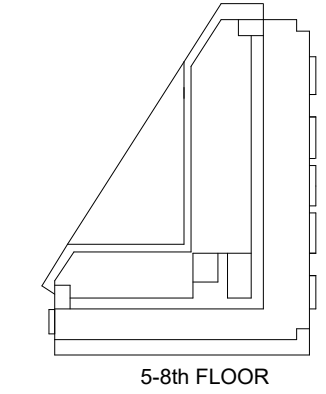
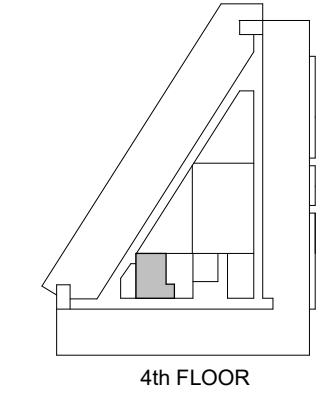
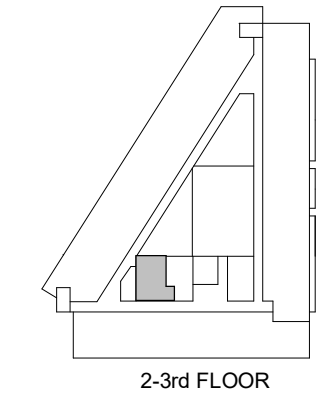
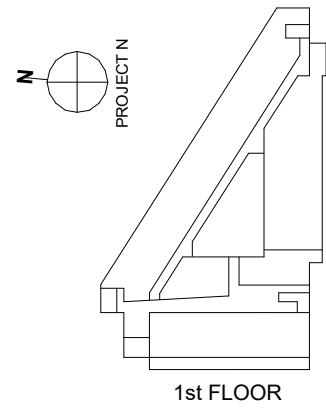

Schedule 'A'
652 PRINCESS STREET, KINGSTON, ON.

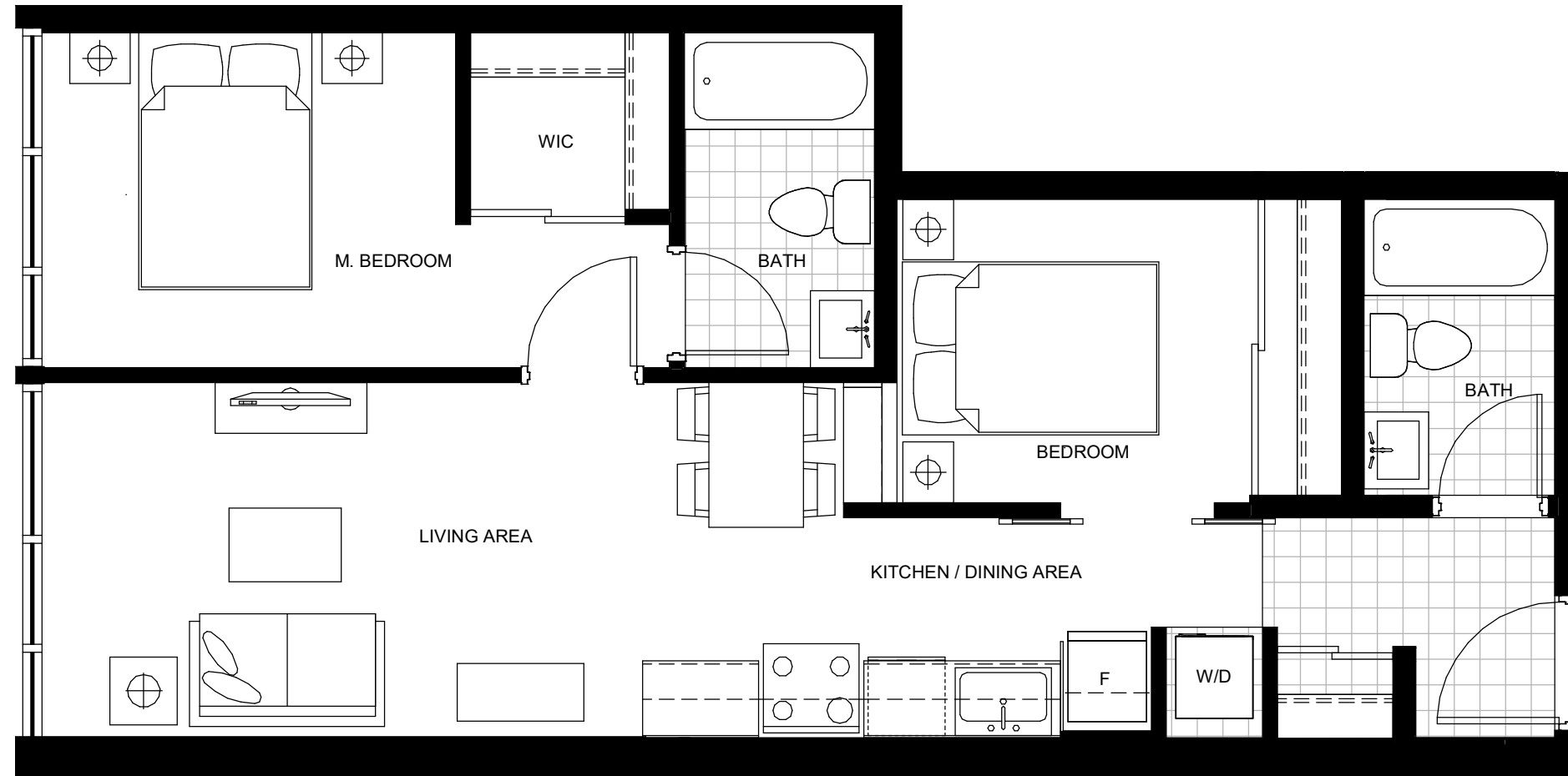

UNITS: 238, 338, 439
UNITS: 241, 341, 442
AREA: 726.99 SF

UNIT TYPE 2B4 720.37 SF

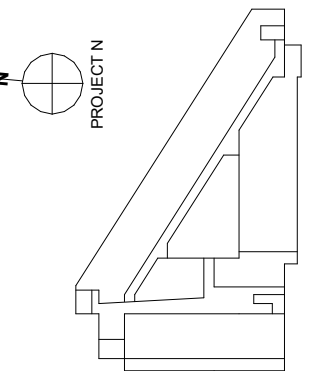

1st FLOOR

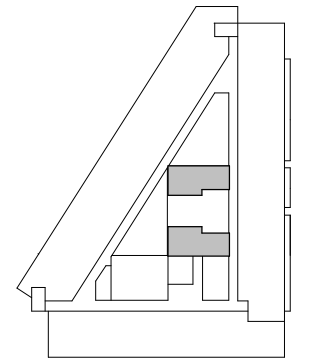

2-3rd FLOOR

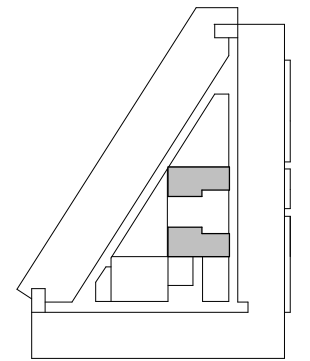

4th FLOOR

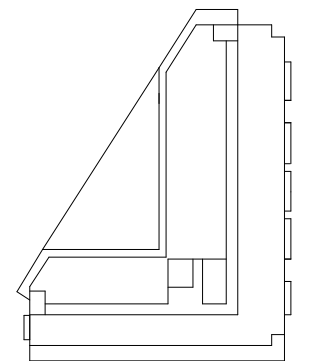

5-8th FLOOR

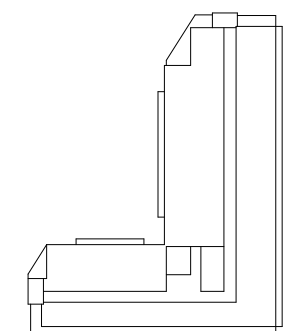

9th FLOOR

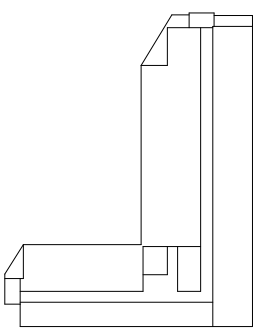

10th FLOOR

Schedule 'A'
652 PRINCESS STREET, KINGSTON, ON.

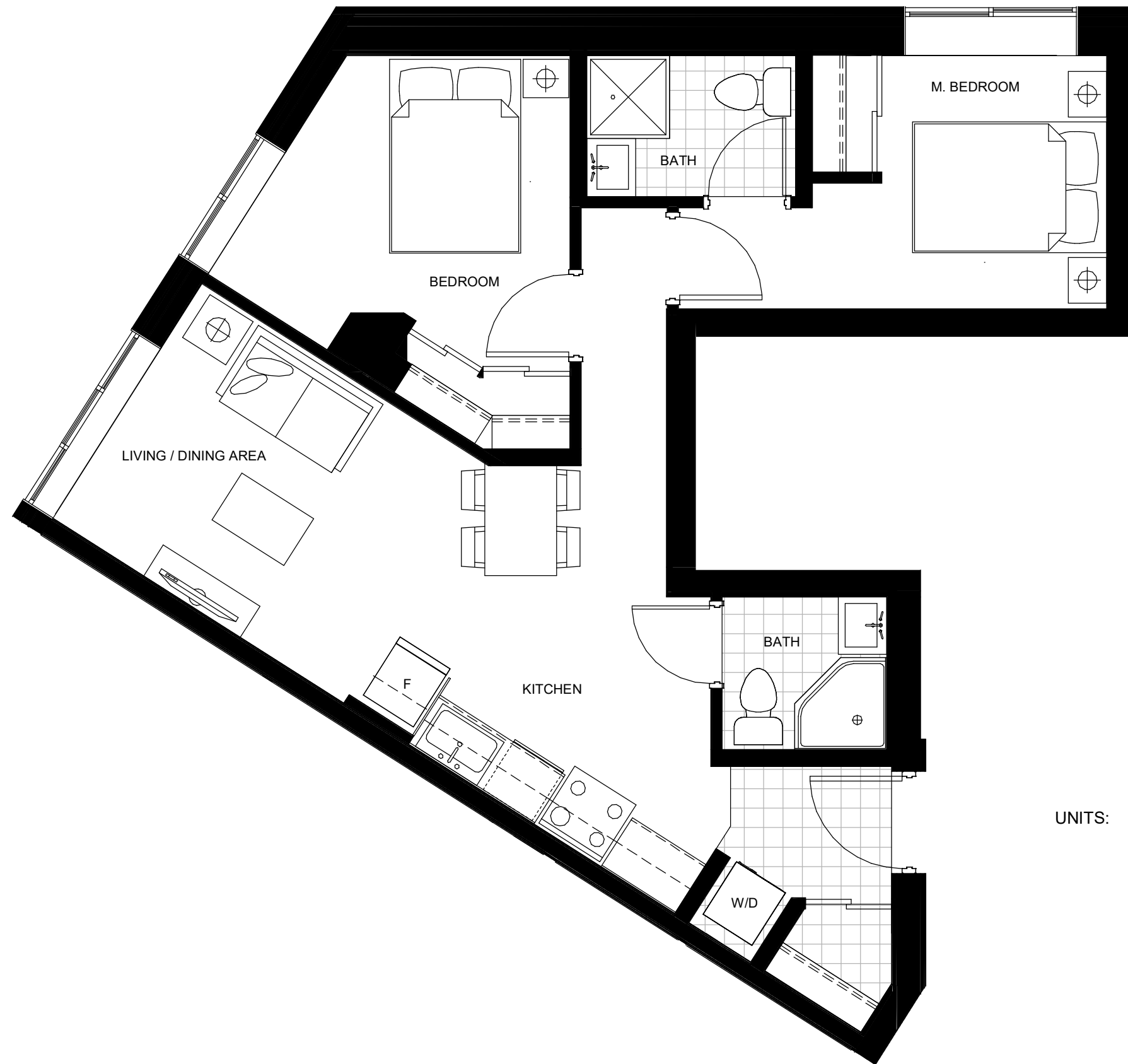

UNIT TYPE 2B5 778.09 SF

UNITS: 213, 313, 413

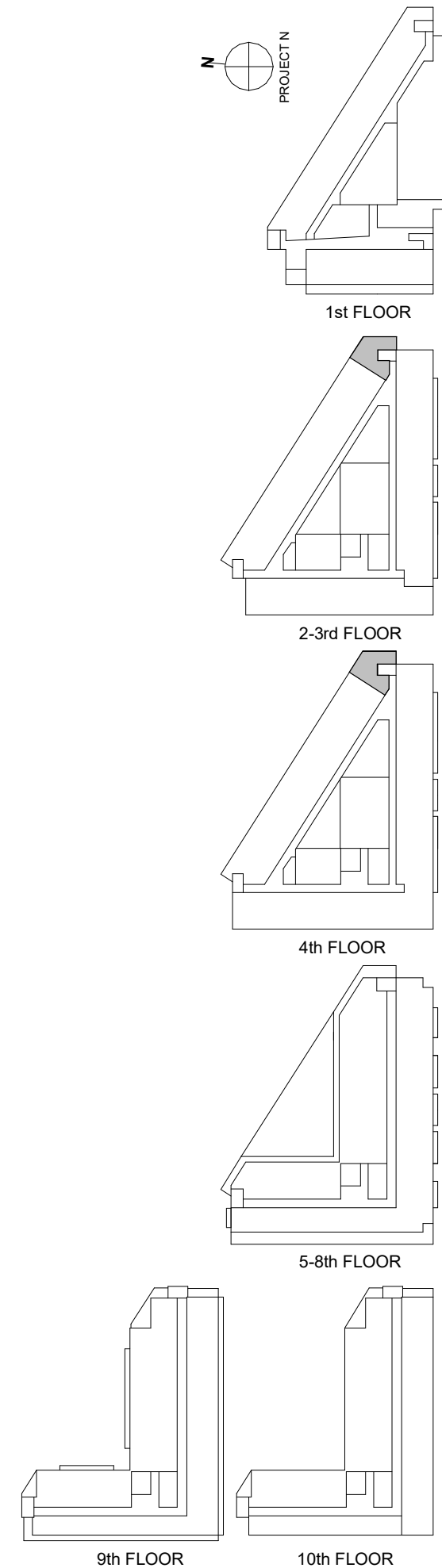

Schedule 'A'
652 PRINCESS STREET, KINGSTON, ON.

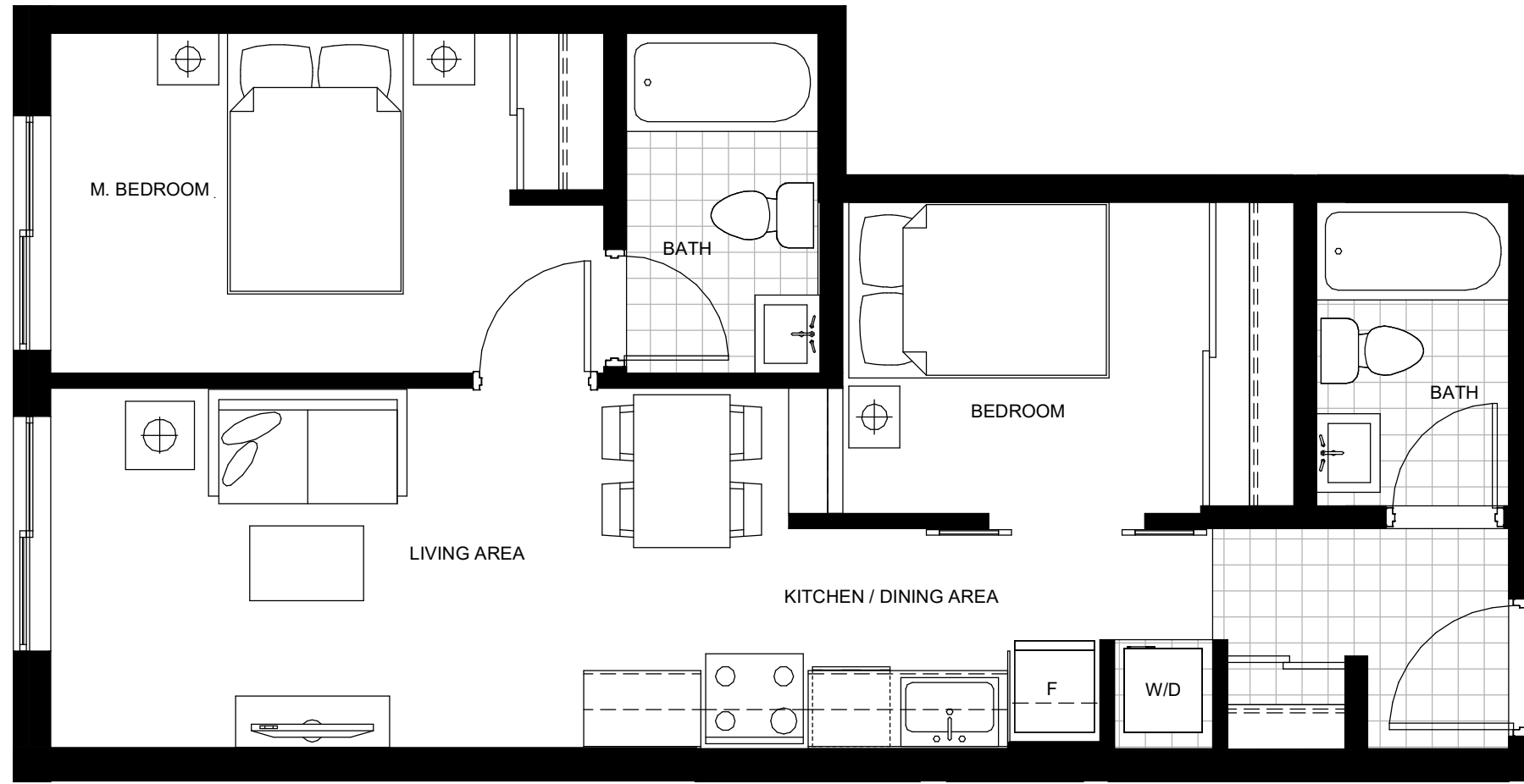

UNITS: 622, 722, 822



1st FLOOR

2-3rd FLOOR

4th FLOOR

5-8th FLOOR

9th FLOOR

10th FLOOR

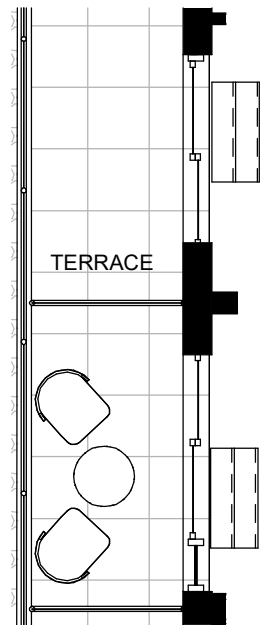

UNITS: 516, 519

UNIT TYPE 2B6

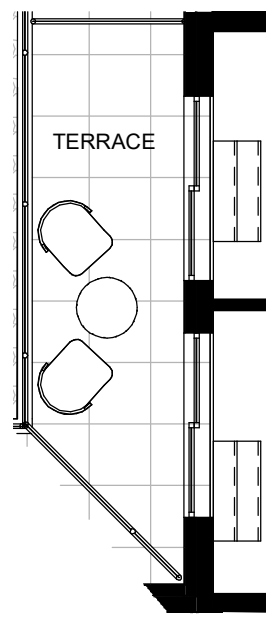

UNITS: 522
AREA: 683.86 SF

672.26 SF

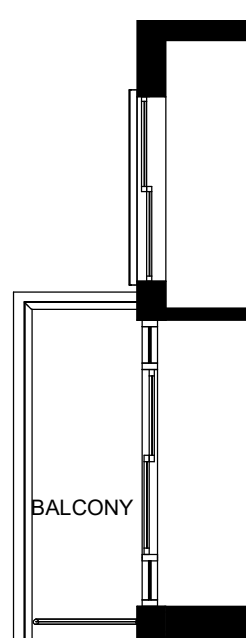

UNITS: 616, 716, 816, 914

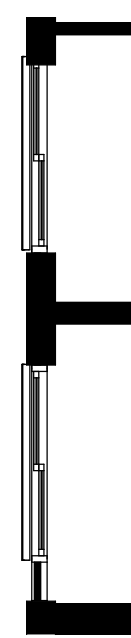

UNITS: 920,
1014, 1017, 1020
AREA: 683.86 SF

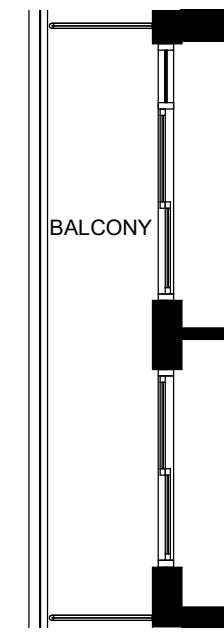

UNITS: 619
719
819
917

Schedule 'A'
652 PRINCESS STREET, KINGSTON, ON.

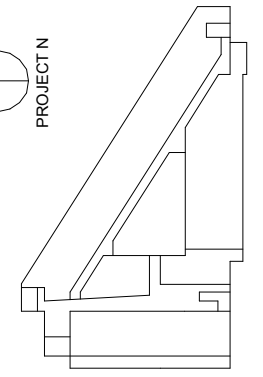

1st FLOOR

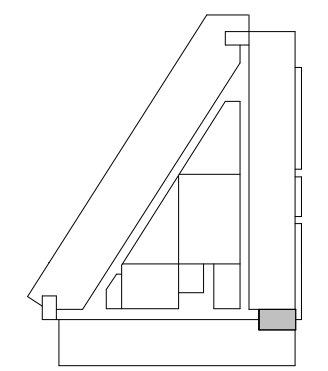

2-3rd FLOOR

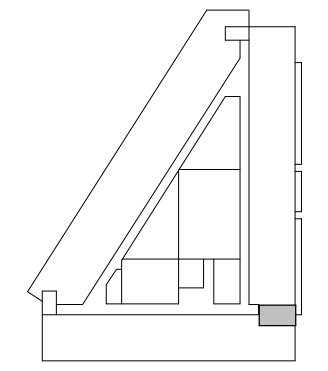

4th FLOOR

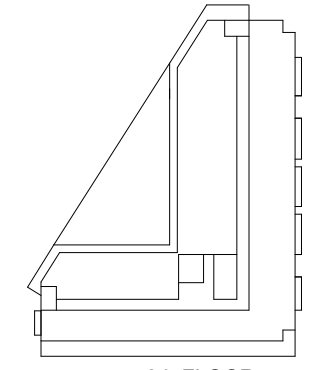

5-8th FLOOR

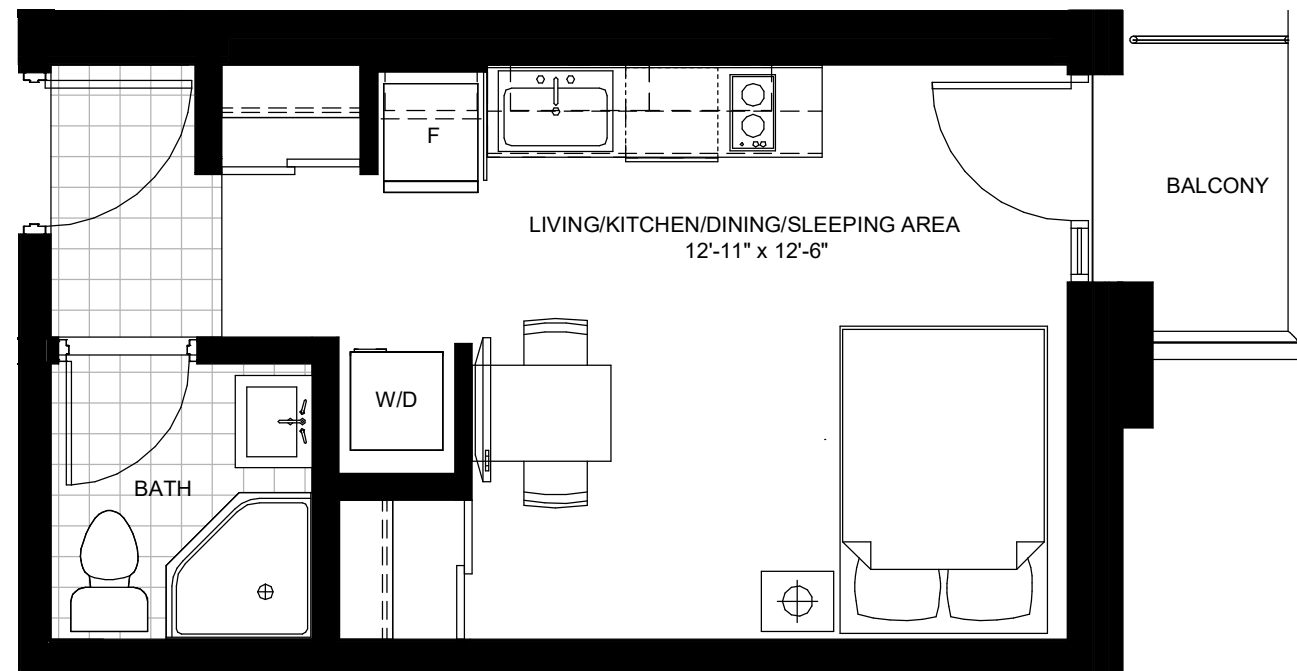

UNITS: 235, 335, 436

UNIT TYPE STUDIO 3 317.57 SF

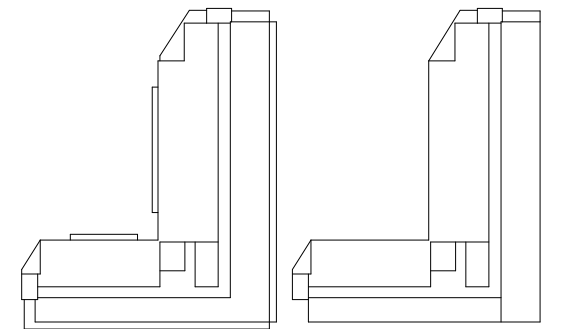

9th FLOOR

10th FLOOR

Schedule 'A'
652 PRINCESS STREET, KINGSTON, ON.

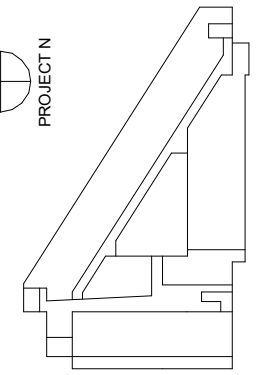
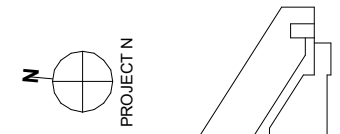

1st FLOOR

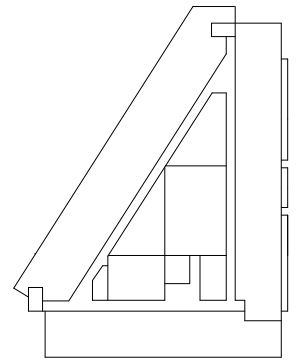

2-3rd FLOOR

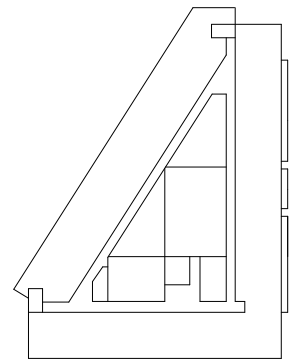

4th FLOOR

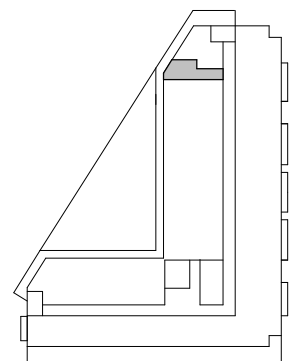

5-8th FLOOR

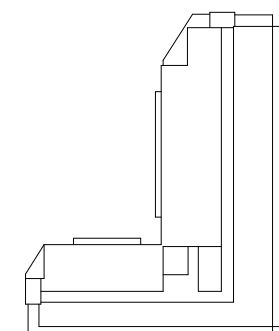

9th FLOOR

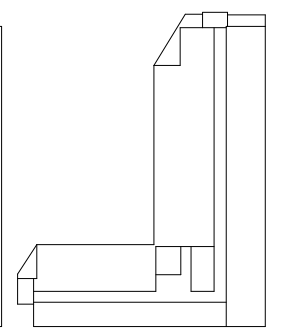

10th FLOOR



UNIT TYPE STUDIO 5 352.44 SF